

500

500C



O W N E R H A N D B O O K

This Owner Handbook is intended to show the vehicle's operating conditions.

For the enthusiast user who wants to have insights, curiosities and detailed information about the characteristics and functions of the vehicle, Fiat gives the opportunity to consult a dedicated section which is available in electronic format.

ONLINE VEHICLE OWNER HANDBOOK

The following symbol  is reported within the text of the Owner Handbook, next to the subjects for which details are provided.

Go to the www.mopar.eu/owner website and access your personal area.

The “Maintenance and care” page includes all the information about your vehicle and the link to access eLUM, where you will find all the details of the Owner Handbook.

Alternatively, to access this information, go to the Internet website at <http://aftersales.fiat.com/elum/>.

The eLUM website is free and will allow you, among many other things, to easily consult the on-board documents of all the other vehicles of the Group.

Have a nice reading and happy motoring!

Dear Customer,

We would like to congratulate and thank you for choosing a Fiat .

We have written this handbook to help you get familiar with all the features of your car.

Here you will find information, advice and important warnings regarding use of your vehicle and how to achieve the best performance from the technical features of your Fiat .

You are advised to read it right through before taking to the road for the first time, to become familiar with the controls and above all with those concerning brakes, steering and transmission; at the same time, you can understand the car behaviour on different road surfaces.

This document also provides a description of special features and tips, as well as essential information for the safe driving, care and servicing of your Fiat over time .

After reading it, you are advised to keep the handbook inside the car, for an easy reference and for making sure it remains on board the car should it be sold.

In the attached Warranty Booklet you will also find a description of the Services that the manufacturer offers to its customers, the Warranty Certificate, the detail of the terms and conditions for maintaining its validity and the range of additional services available to Fiat Customers.

We are confident that these will bring you closer to your new car and make you appreciate the assistance provided by the Stellantis team.

Enjoy reading. Happy motoring!

WARNING

This Owner Handbook describes all versions of the Fiat ; please consider only the information relevant to your vehicle's trim level, engine and version. All data contained in this publication are purely indicative. Stellantis Europe S.p.A. can modify the specifications of the vehicle model described in this publication at any time, for technical or marketing purposes. For further information, contact a Fiat Dealership.

ESSENTIAL INFORMATION!

REFUELLING



Petrol engines: only refuel with unleaded petrol with octane rating (RON) not less than 95 in compliance with the European specification EN228. Using these mixtures may cause misfiring and driving issues, as well as damage fundamental components of the supply system.

LPG engines: refuel only with LPG for motor vehicles conforming to the European specification EN589. The use of other products or mixtures may damage the engine beyond repair and consequently invalidate the warranty, due to the damage caused. For further details on the use of the correct fuel see the "Refuelling the car" chapter in the "Starting and driving" section.

STARTING THE ENGINE



Make sure that the handbrake is engaged and place the gear lever in neutral. Fully depress the clutch pedal, without pressing the accelerator, then turn the ignition key to the MAR position and wait for the warning light  to switch off: turn the ignition key to the AVV position and release it as soon as the engine starts.

Versions with Dualogic transmission: make sure that the handbrake is engaged and that the gear lever is in P (Parking) or N (Neutral), fully depress the brake pedal, then turn the ignition key to AVV and release it as soon as the engine is started.

PARKING ON FLAMMABLE MATERIAL



The catalytic converter develops high temperatures during operation. Do not park the car on grass, dry leaves, pine needles or other flammable material: fire hazard.

RESPECTING THE ENVIRONMENT



The vehicle is fitted with a system that carries out a continuous diagnosis of the emission-related components in order to help protect the environment.

ELECTRICAL ACCESSORIES



If, after buying the vehicle, you decide to add electrical accessories (with the risk of gradually draining the battery), contact a Fiat Dealership. They can calculate the overall electrical requirement and check that the vehicle's electric system can support the required load.

SCHEDULED SERVICING



Correct maintenance of the car is essential for ensuring that it maintains its performance and its safety features, its environmental friendliness and low running costs for a long time to come.

USE OF THE OWNER HANDBOOK

OPERATING INSTRUCTIONS

Each time an instruction is given that concerns direction (left/right or forward/backward), it is written to be read from the perspective of an occupant in the driver's seat. If a direction is written from a different perspective, it will be specified as such in the text as appropriate.

The figures in the Owner Handbook are provided by way of example only: this might imply that some details of the image do not correspond to the actual arrangement of your car. In addition, the Handbook has been conceived considering vehicles with steering wheel on the left side; it is therefore possible that on vehicles with steering wheel on the right side, the position or construction of some controls is not exactly mirror-like with respect to the figure.

To identify the chapter with the information needed you can consult the index at the end of this Owner Handbook.

Chapters can be rapidly identified with dedicated graphic tabs, at the side of each odd page. A few pages further there is a key for getting to know the chapter order and the relevant symbols in the tabs. There is in any case a textual indication of the current chapter at the side of each even page.

WARNINGS AND CAUTIONS

While reading this Owner Handbook you will find a series of **WARNINGS** to prevent procedures that could damage your car. There are also **CAUTIONS** that must be carefully followed to prevent incorrect use of the components of the vehicle, which could cause accidents or injuries.

Therefore, all **WARNINGS** and **CAUTIONS** must always be carefully followed.

WARNINGS and **CAUTIONS** are recalled in the text with the following symbols:



personal safety;



car safety;



environmental protection.

NOTE These symbols, when necessary, are indicated besides the title or at the end of the line and are followed by a number. That number recalls the corresponding warning at the end of the relevant section.

WARNING Where the text refers to the "conventional battery", it means the 12 V service lead battery located in the engine compartment; where the text refers to the "auxiliary battery", it means the 12 V lithium traction battery for the hybrid system,

located under the left seat (1.0 FireFly Hybrid version). There is no "auxiliary battery" in the 1.2 8V 69 HP and 0.9 TwinAir versions. The term "supplementary battery" means a lead battery outside the car for jump starting.

SYMBOLS

Some car components have colored labels with symbols indicating precautions to be observed when using this component. A plate summarising these symbols can also be found under the bonnet.

MULTIMEDIA CONTENT

(for the 1.0 FireFly Hybrid version)



The description of some features of the car is completed by video support. To view the contents:

- check availability on your mobile device of an app for reading QR codes;
- scan the QR code located at the relevant topic using your mobile device;
- access the video content.

NOTE The multimedia content is only available in some languages.

CHANGES/ALTERATIONS TO THE CAR

WARNING Any change or alteration of the car might seriously affect its safety and road grip, thus causing accidents, in which the occupants could even be fatally injured.

WARNING The use of these devices inside the passenger compartment (without an external aerial) may cause the electrical systems to malfunction. This could compromise the safety of the car in addition to constituting a potential hazard for passengers' health.

ACCESSORIES PURCHASED BY THE OWNER

If after buying the car, you decide to install electrical accessories that require a permanent electrical supply (e.g. radio, satellite anti-theft system, etc.) or accessories that in any case burden the electrical supply, contact a Fiat Dealership, which will check whether the electrical system in the car is able to support the required load, or if it needs to be integrated with a more powerful conventional lead battery.

WARNING Take care when fitting additional spoilers, alloy wheel rims or non-standard wheel hubs: they could reduce the ventilation of the brakes and affect efficiency under sharp, repeated braking or on long descents. Make sure that nothing obstructs the pedal stroke (mats, etc.).

INSTALLING ELECTRICAL/ELECTRONIC DEVICES

Electrical and electronic devices installed after buying the car in the context of after-sales service must carry the following label .

The manufacturer authorises the fitting of transceivers provided that installation is carried out at a specialised centre, in a workmanlike fashion and in compliance with manufacturer's specifications.









WARNING Traffic police may not allow the car on the road if devices have been installed which modify the features of the car. This may also cause invalidation of warranty in relation to faults caused by the change either directly or indirectly related to it. The manufacturer shall not be liable for damage caused by the installation of accessories either not supplied or recommended by the manufacturer or not installed in compliance with the provided instructions.

RADIO TRANSMITTERS AND MOBILE PHONES

Radio transmitter equipment (car mobile phones, CB radios, amateur radio etc.) cannot be used inside the car unless a separate aerial is mounted on the roof.

Transmission and reception of these devices may be affected by the shielding effect of the car body. As far as the use of EC-approved mobile phones is concerned (GSM, GPRS, UMTS, LTE), follow the usage instructions provided by the mobile phone Manufacturer.

WARNING The use of these devices inside the passenger compartment (without an external aerial) may cause the electrical systems to malfunction. This could compromise the safety of the car in addition to constituting a potential hazard for passengers' health.

GETTING TO KNOW YOUR CAR	
KNOWING THE INSTRUMENT PANEL	
SAFETY	
STARTING AND DRIVING	
IN AN EMERGENCY	
MAINTENANCE AND CARE	
TECHNICAL SPECIFICATIONS	
MULTIMEDIA	
CONTENTS	



GETTING TO KNOW YOUR CAR

In-depth knowledge of your new car starts here.

The handbook you are reading will tell you how things are done, and how it works in a simple, direct way.

That's why we advise you to read it seated comfortably on board, so that you can see what is described here for yourself.

DASHBOARD	12
THE KEYS.....	14
IGNITION DEVICE	15
THE FIAT CODE SYSTEM	16
DOORS	16
SEATS.....	17
HEAD RESTRAINTS	20
STEERING WHEEL.....	21
REAR-VIEW MIRRORS	21
EXTERNAL LIGHTS	22
INTERIOR LIGHTS.....	26
WINDOW WASHING	26
CLIMATE CONTROL SYSTEM	29
ELECTRIC WINDOWS	35
ROOF	35
SOFT TOP	37
BOOT	42
BONNET.....	43
INTERIOR FITTINGS	43
ROOF RACK/SKI RACK	45
VERSION WITH LPG SYSTEM	46
RED SPECIAL SERIES	49



DASHBOARD

The presence, graphics and position of panels, controls, instruments and indicators may vary according to the different versions.

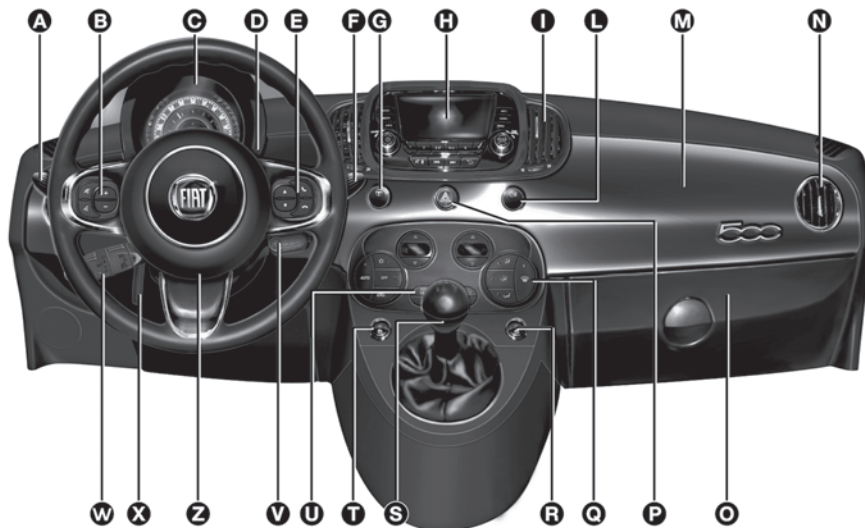

I

F0S0641

A. Lights/direction indicator stalk - B. Audio controls on the steering wheel - C. Instrument panel - D. Headlight alignment corrector - E. Audio controls on the steering wheel - F. Windscreen wiper/washer and rear window wiper - G. Dualdrive electric power steering (CITY function)/ECO function - H. **Uconnect™** - I. Central air diffusers - L. Front/rear fog lights - M. Passenger's airbag - N. Side air diffusers - O. Glove compartment - P. Hazard warning lights - Q. Air conditioning system controls - R. Right electric window - S. Gear lever - T. Left electric window - U. ASR-OFF button - V. Ignition device - W. Cruise Control/Speed Limiter stalk - X. Steering wheel adjustment lever - Z. Driver's airbag

Dashboard with Sport steering wheel

(for versions/markets, where provided)

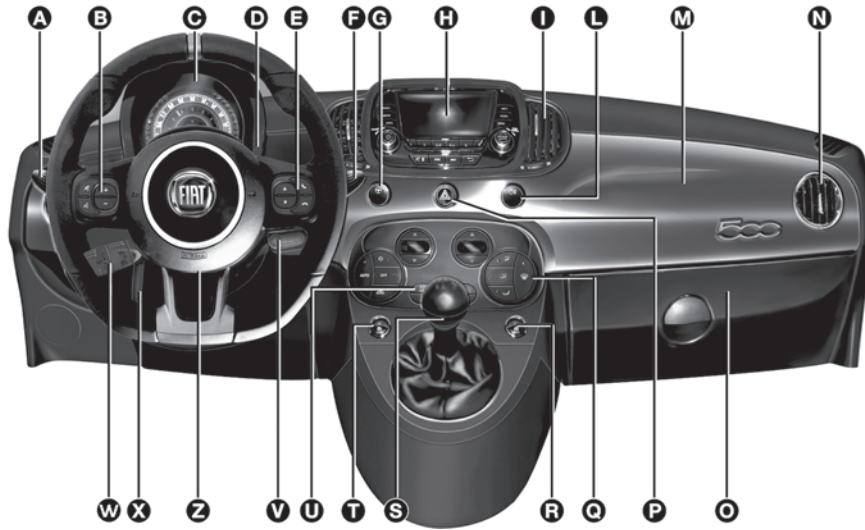

2

F0S0642

A. Lights/direction indicator stalk - B. Audio controls on the steering wheel - C. Instrument panel - D. Headlight alignment corrector - E. Audio controls on the steering wheel - F. Windscreen wiper/washer and rear window wiper - G. Dualdrive electric power steering (CITY function)/ECO function - H. **Uconnect™** - I. Central air diffusers - L. Front/rear fog lights - M. Passenger's airbag - N. Side air diffusers - O. Glove compartment - P. Hazard warning lights - Q. Air conditioning system controls - R. Right electric window - S. Gear lever - T. Left electric window - U. ASR-OFF button - V. Ignition device - W. Cruise Control/Speed Limiter stalk - X. Steering wheel adjustment lever - Z. Driver's airbag



THE KEYS



MECHANICAL KEY

The metal insert (A) fig. 3 operates:

- the ignition device;
- the doors and the tailgate locks (for versions/markets where provided);



3

F0S0003

KEY WITH REMOTE CONTROL

(for versions/markets, where provided)

The metal insert (A) fig. 4 operates:

- the ignition device;
- the door lock;

Pressing button (B) fig. 4 allows the opening/closing of the metal insert.

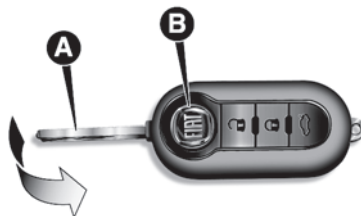

4

F0S0004



Unlocking the doors and the tailgate

Briefly press button : for unlocking of doors and tailgate, timed switching-on of internal lights and double flashing of direction indicators (for versions/markets where provided).

The doors are unlocked automatically if the fuel cut-off system intervenes.

Locking the doors and the tailgate

Brief press of the button: remote locking of doors and tailgate, switching-off of roof light and single flashing of direction indicators (for versions/markets, where provided). If one or more door are open, the doors will not be locked. This is indicated by a rapid flashing of the direction indicators (for versions/markets, where provided). If the luggage compartment is open, the doors will, however, be locked.

When a speed of over 20 km/h is reached, the doors will be automatically locked if the specific function was set (for versions/markets, where provided) with the Setup menu.

Opening the tailgate by the remote control

Press button to release (open) the tailgate remotely.

The tailgate opening is indicated by double flashing of direction indicators.



REQUEST FOR ADDITIONAL REMOTE CONTROLS

The system can recognise up to 8 keys with incorporated remote control. Should a new remote control be necessary, contact a Fiat Dealership, taking with you the CODE Card, an ID document and the car ownership documents.

REPLACING THE BATTERY IN THE KEY WITH REMOTE CONTROL



To replace the battery, proceed as follows:

- press button (A) fig. 5 and open the metal insert B;
- turn screw (C) to using a fine bit screwdriver;

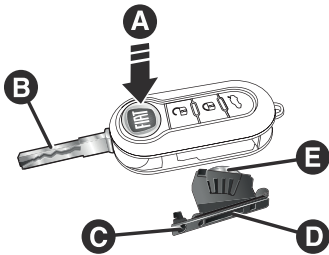

5

F0S0005

□ take out the battery case (D) and replace the battery (E) making sure that polarities are correct;

□ refit the battery holder (D) inside the key and lock it turning the screw to (C) to .

REPLACING THE COVER IN THE KEY WITH REMOTE CONTROL

Proceed as shown in the figure fig. 6 and fig. 7 to replace the cover of the key with remote control.

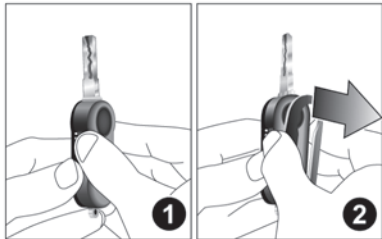

6

F0S0352

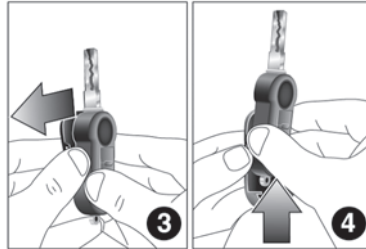

7

F0S0353



WARNING

- 1)** Do not swallow the battery. Danger of chemical burns. The keys contain a small battery. If the battery is swallowed, it can cause severe internal burns in just 2 hours and cause death. Keep new and used batteries out of the reach of children. If the battery compartment does not close securely, discontinue use of the product and keep it out of reach of children. If you believe that batteries may have been swallowed or inserted inside the body, seek medical attention immediately. The emergency key (where provided) must be immediately inserted into the electronic key to prevent easy access to the battery.
- 2)** Press button (B) only with the key away from your body, especially your eyes and from objects which could get damaged (e.g. your clothes). Do not leave the key unattended to avoid the button being accidentally pressed while it is being handled, e.g. by a child.



IMPORTANT

- 1)** The electronic components inside the key may be damaged if the key is subjected to strong shocks. In order to ensure complete efficiency of the electronic devices inside the key, it should never be exposed to direct sunlight.



IMPORTANT

- 1)** Used batteries should be disposed of, as specified by law, in the special containers, otherwise take them to a Fiat Dealership, which will deal with their disposal.

IGNITION DEVICE



The key can be turned to 3 different positions fig. 8:

- STOP: engine off, key can be removed, steering column locked. Some electrical devices (e.g. audio system, central door locking system, etc.) can operate;
- MAR: driving position. All electrical devices are enabled;
- AVW: engine starting.



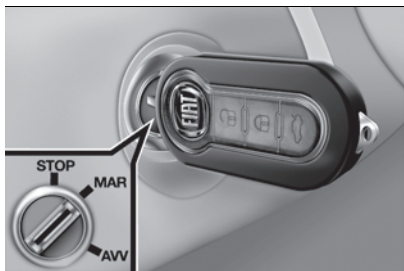

8

F0S0006

The ignition device is fitted with a safety system that requires the ignition key to be turned back to STOP if the engine does not start, before the starting operation can be repeated.

STEERING LOCK



Engagement: when the key is in position STOP, remove the key and turn the steering wheel until it is locked.

Turning off: move the steering wheel slightly as you turn the ignition key to MAR.



WARNING

3) If the ignition device has been tampered with (e.g. attempted theft), have it checked over by a Fiat Dealership before driving again.

4) Always remove the key when you leave your car to prevent someone from

accidentally operating the controls. Remember to engage the handbrake. Engage 1st gear if the car is parked uphill or reverse if the car is parked downhill. Never leave children unattended in the car.

5) Never remove the key while the car is moving. The steering wheel will automatically lock as soon as it is turned. This holds true for cars being towed as well.

6) It is absolutely forbidden to carry out any after-market operation involving steering system or steering column modifications (e.g. installation of anti-theft device) that could adversely affect performance, invalidate the warranty, cause **SERIOUS SAFETY PROBLEMS** and also result in the car not meeting type-approval requirements.

THE FIAT CODE SYSTEM

This is an electronic engine locking system which increases protection against attempted thefts of the car. It is automatically activated when the ignition key is removed. Each time the car is started by turning the ignition key to MAR, the Fiat CODE system control unit sends a recognition code to the Powertrain Control Module to deactivate the immobiliser. If, during starting, the code has not been correctly recognised, the  warning light on the instrument panel turns on, or a symbol is shown on the display

on some versions. In this case, turn the key to STOP and then to MAR; if it is still locked, try again with the other keys that come with the car. Contact a Fiat Dealership if you still cannot start the engine.

WARNING Each key has its own code which must be stored by the system's control unit. Contact a Fiat Dealership to have new keys (up to 8) stored with a code.

DOORS



OPENING/CLOSING WITH KEY

To open from outside (driver's door): turn the key to position (1) fig. 9 and pull the handle.



9

F0S0099

On versions with central locking, when the key is turned, the doors and the tailgate are simultaneously unlocked.

To lock from outside: with driver's door fully closed, turn the key to position (2) fig. 9.

It is possible to lock the passenger side door only from inside bringing the handle to position (2) fig. 10.

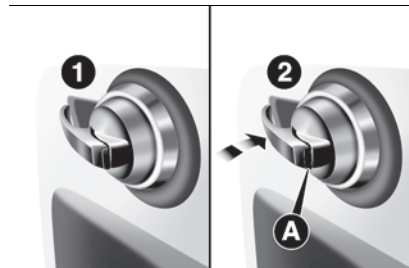

10

F0S0357

On versions with central locking, when the key is turned, the doors and the tailgate are simultaneously locked.

Lock / Unlock from inside act on the handles on the door panels fig. 10.

Position (1): the door is unlocked.

Position (2): the door is locked.

On versions with door central locking, the driver's and passenger's side handles lock/unlock both doors and tailgate.

WARNING The locked door condition is indicated by the red symbol (A) fig. 10 on the interior door handle.

With remote control

Press the  button: to lock the doors.

Press the  button: to unlock the doors.



7) Before opening a door, ensure that you can do it in conditions of safety. Open the doors only when the car is stationary.



2) Make sure to take the key with you once a door or the tailgate is locked, to prevent locking the same key inside the car. If the key is locked inside, it can only be retrieved by using the second key provided.

SEATS

FRONT SEATS

 8) 9)

 3)

Longitudinal adjustment

Lift lever (A) fig. 11 and push the seat forwards or backwards: in the driving position, you should be able to rest your arms on the rim of the steering wheel.

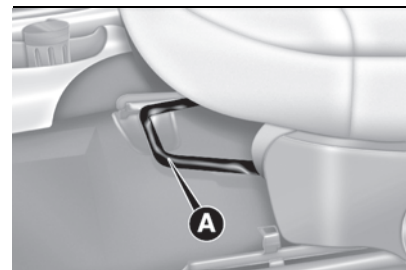

11

F0S0013

 10)

Backrest angle adjustment

Turn knob (C) fig. 12.



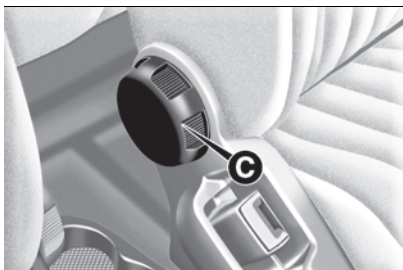

12

F0S0014

Height adjustment

(for versions/markets, where provided)
Operate lever (B) fig. 13 to lift or lower the rear part of the cushion to achieve the most comfortable driving position.

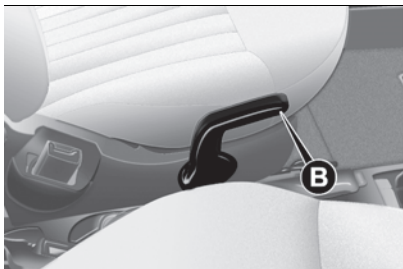

13

F0S0015

Reclining the backrest



To fold the backrest over, adjust lever (D) fig. 14 (movement 1) and push

the backrest forwards until it locks (movement 2).

Then release lever (D) and, pushing on the backrest, slide the seat forward (movement 3).

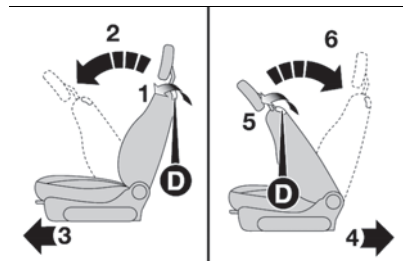

14

F0S0154

Driver side and passenger side, with position memory

(for versions/markets, where provided)

To bring back the seat in its initial position proceed as follows:

- slide the seat backwards pushing on the backrest, until the seat is locked (movement 4);
- adjust lever (D) fig. 14 (movement 5);
- raise the backrest (movement 6) until you hear the lock click.

WARNING Using lever (D) fig. 14 before locking the seat in its initial position will cause the initial seat position to be lost. In this case the position of the seat must be restored through lengthwise adjustment lever (A) fig. 11.

Passenger side without position memory

To bring back the seat in its initial position proceed as follows:

- slide the seat backwards pushing on the backrest to the desired position (movement 4);
- adjust lever (D) fig. 14 (movement 5);
- raise the backrest (movement 6) until you hear the lock click.

The type of reattachment manoeuvre has been chosen to guarantee the safety of the occupant.

If an obstacle is present (e.g. a bag) and the seat cannot be returned to its original position, the mechanism reattaches the seat only positioning the backrest to ensure that the seat is correctly attached to its guides.

REAR SEATS EXTENDING THE BOOT



The separate rear seats allow partial fig. 15 or total fig. 16 boot extension.



15

F0S0043



16

F0S0044

Partial extension (50/50)

(for versions/markets, where provided)

Proceed as follows:

- ❑ remove the parcel shelf, by releasing it from its two side pins and pulling it out;
- ❑ remove the rear seat head restraints (where provided); see the "Head restraints" paragraph in this chapter;

- ❑ check that the seat belt is fully extended and not twisted;
- ❑ operate lever (A) fig. 17 or (B) to release the left hand or right hand part of the backrest respectively and guide it onto the cushion.

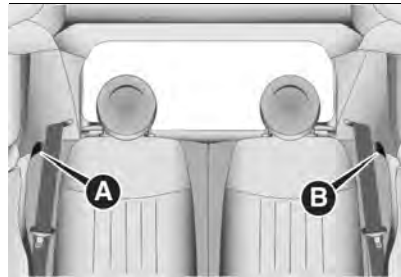

17

F0S0017

WARNING To return the backrest to its correct position, we recommend operating from the outside through the doors.

Total extension

Tilting the rear seat completely forwards allows maximum loading volume.

Proceed as follows:

- ❑ remove the parcel shelf, by releasing it from its two side pins and pulling it out;
- ❑ remove the rear seat head restraints (where provided); see the "Head restraints" paragraph in this chapter;

- ❑ check that the belt straps are correctly extended and not twisted;
- ❑ operate the levers (A) fig. 17 and (B) to release the backrests and guide them onto the cushion.

WARNING To return the backrest to its correct position, we recommend operating from the outside through the doors.

Repositioning seat backrests

Raise the backrests and push them back until the locking click of both retainers is heard.

Position the seat belt buckles upwards and set the cushion to the normal use position.

WARNING When returning the backrest to its normal position, make sure that it is correctly fastened and that you hear the lock click.

PRECAUTIONS FOR SITTING CORRECTLY

(for the 1.0 Firefly Hybrid version)

The auxiliary lithium battery (A) fig. 18 for the hybrid system is installed under the front left seat.



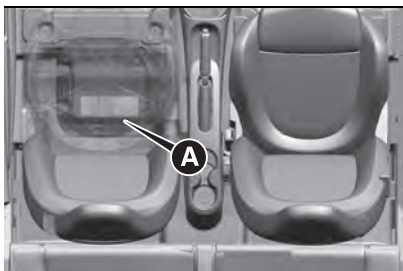

18

F0S0697

There is a label (fig. 19) on the battery cover, which warns not to rest your feet on it.

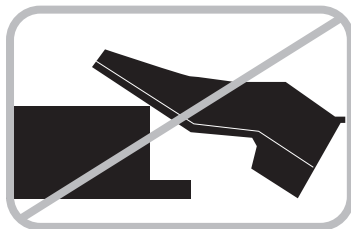

19

F0S0699



5)



WARNING

- 8)** All adjustments must be made with the car stationary and engine stopped.
- 9)** If a side bag is fitted, it is dangerous to use seat covers not available from Lineaccessori MOPAR®.
- 10)** After releasing the adjustment lever, always check that the seat is locked on the guides by trying to move it back and forth. If the seat is not locked into place, it may unexpectedly slide and cause the driver to lose control of the car.
- 11)** Make sure the backrests are properly secured at both sides to prevent them from moving forward, in the event of sharp braking, with possible impact with of the passengers.



IMPORTANT

- 3)** The fabric upholstery of the seats has been designed to withstand long-term wear deriving from normal use of the car. Some precautions are however required. Avoid prolonged and/or excessive rubbing against clothing accessories such as metal buckles and Velcro strips which, by applying a high pressure on the fabric in a small area, could cause it to break, thereby damaging the upholstery.
- 4)** Before tilting the backrest, remove any objects on the seat cushion.
- 5)** Do not rest your feet on the protective cover of the auxiliary lithium battery under the front left seat to avoid damaging the cover or battery.

HEAD RESTRAINTS



12)

FRONT Adjustment

Headrests can be adjusted in height.

Upward adjustment: raise the head restraint until it clicks into place.

Downward adjustment: press button (A) fig. 20 and lower the head restraint.



20

F0S0033



13)

REAR

(for versions/markets, where provided)

Adjustment

Upward adjustment (usage condition): raise the head restraint until it clicks into place.

Downward adjustment: simultaneously press the buttons A fig. 21 and B at the sides of the two supports, and lower the head restraint.



21

F0S0034

The particular shape of the head restraint deliberately interferes with the correct support of the rear passenger's back on the backrest in order to force them to lift the head restraint for correct use.

WARNING If the rear seats are used, always set the head restraints in the "completely raised" position.

Removal

To remove the rear head restraints press buttons (A) fig. 21 and (B) at the side of the two supports simultaneously and lift them out upwards. The rear head restraints must be lifted out with the backrest released and tilted toward the passenger compartment or with the tailgate open.



WARNING

12) All adjustments must be carried out only with the car stationary and engine off. Head restraints must be adjusted so that the head, rather than the neck, rests on them. Only in this case they can protect your head correctly.

13) To make the best use of the head restraint's protective action, adjust the backrest so that you are sitting upright and keep your head as close as possible to the head restraint.

STEERING WHEEL



14) 15)

The steering wheel can be adjusted vertically.

To adjust bring the lever (A) fig. 22 downward in position (2), then adjust the steering wheel to the most suitable position and lock it in this position bringing the lever (A) in position (1).

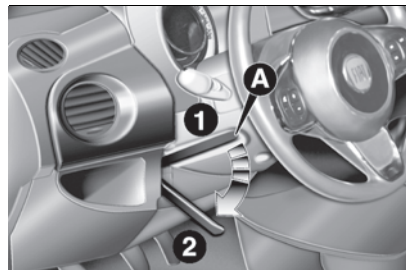

22

F0S0567



WARNING

14) All adjustments must be carried out only with the car stationary and engine off.

15) It is absolutely forbidden to carry out any after-market operation involving steering system or steering column modifications (e.g.: installation of anti-theft device) that could badly affect performance and safety, invalidate the warranty and also result in non-compliance of the car with type-approval requirements.

REAR-VIEW MIRRORS

INTERIOR MIRROR

The mirror is fitted with a safety device that causes its release in the event of a violent impact with the passenger.

Lever (A) fig. 23 can be used to move the mirror to two different positions: normal or anti-glare.

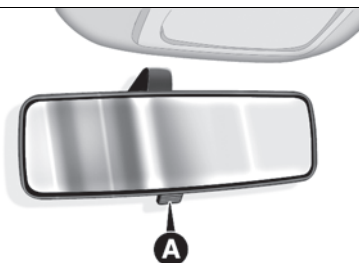

23

F0S0019

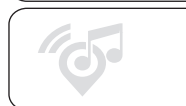

ELECTROCHROMIC REAR-VIEW MIRROR

(for versions/markets, where provided)
Some versions have an electrochromic mirror with automatic anti-glare function.

There is an ON/OFF button on the lower part of the mirror for activating/deactivating the electrochromic function. When the function is active, a LED on the mirror is active. When reverse is engaged, the mirror is automatically set for daytime use.

DOOR MIRRORS

16)

Manual adjustment

The door mirror can be adjusted from outside by exerting a slight pressure on the four sides of the glass.

Electric adjustment

Proceed as follows:

- select the mirror using selector (B) fig. 24;
- adjust the mirror using the joystick fig. 24 in the four directions.

Folding the mirrors

When required (for example when the mirror causes difficulty in narrow spaces) it is possible to fold the mirror by moving it from position 1 fig. 25 (open), to position 2 (closed).

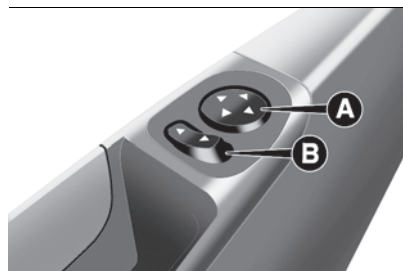

24

F0S0020

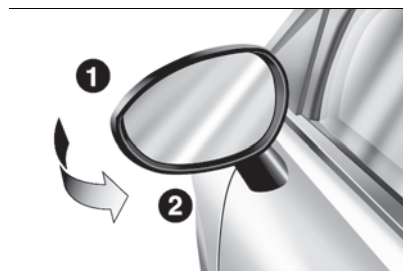

25

F0S0035



WARNING

16) As door mirrors are curved, they may slightly alter the perception of distance. While driving the mirrors must remain in position (1).

EXTERNAL LIGHTS



26

F0S0791



27

F0S0792



DAYTIME RUNNING LIGHTS (DRL)

17) 18)

For cars without the AUTO function: with the ignition key turned to MAR and the ring turned to position **O** fig. 26 or fig. 27 (for markets/versions where provided) the daytime running lights are automatically activated; the other lights and interior lighting remain off.



For cars with the AUTO function: the daytime running lights are turned on automatically by the dusk sensor when the ring is in the AUTO position.

DIPPED BEAM HEADLIGHTS/SIDE LIGHTS

With the ignition key in the MAR position, turn the ring to position  fig. 26 or fig. 27 (for markets/versions where provided). If dipped headlights are activated, the daytime running lights switch off and the side lights and dipped headlights switch on. The  warning light switches on in the instrument panel.

With the selector switch in the AUTO position, the side lights and the dipped beam headlights are controlled by the dusk sensor.

MAIN BEAM HEADLIGHTS

With ring in position , push the stalk forward toward the dashboard (stable position). The  warning light switches on in the instrument panel.



For cars with the AUTO function: with the ring in the AUTO position and the dipped beam headlights on, push the stalk forwards toward the dashboard. When the stalk is pulled towards the steering wheel again, beyond the end of travel position, the main beam headlights deactivate, the dipped

headlights reactivate and the  warning light switches off.

FLASHING THE HEADLIGHTS



To do this, pull the stalk towards the steering wheel (unstable position) fig. 26 or fig. 27 (for versions/markets, where provided) regardless of the ring position.

PARKING LIGHTS

These lights can be turned on with the ignition switch in the STOP position or with the key removed, by moving the left stalk ring first to the  position (or the AUTO position if the vehicle does not have a dusk sensor) and then to position . The  warning light switches on in the instrument panel. Repeat the same operation to switch them off.

DIRECTION INDICATORS

Move the stalk ring fig. 26 or fig. 27 (for versions/markets, where provided) to the following position (stable):

-  **upwards (position 1):** to activate the right direction indicator;
-  **downwards (position 2):** activates the left direction indicator.

"Lane Change" function

Move the lever upwards or downwards (unstable position) for less than half a second and the direction indicator

will flash 3 times to signal a lane change, then immediately switch off automatically.

"FOLLOW ME HOME" DEVICE



This function allows the space surrounding the car to be lit up for the set period of time.

Activation

The "Follow Me Home" device activates by pulling the fig. 26 or fig. 27 (for versions/markets, where provided) stalk towards the steering wheel beyond the end click.

You can activate this function within 2 minutes of turning the engine off. This function allows turning on lights and low beams.

It is possible to set the headlights turning on time by pulling the left lever towards the steering wheel (unstable position) one or more times. In this case, you can choose between 0, 30, 60, 90 and up to a maximum of 210 seconds.

Each time the stalk is operated, the  warning light on the instrument panel switches on. The display shows a message and the time set for the function. The  warning light comes on when the stalk is first moved and stays on until the function is automatically deactivated.



Deactivation

The function is deactivated by turning the headlights or the side lights on, or by pulling the left lever towards the steering wheel (unstable position) for more than 2 seconds, or by turning the ignition device to MAR.

AUTO FUNCTION

(for versions/markets, where provided)

Dusk sensor

This is an infrared LED sensor that works in conjunction with the rain sensor and is located on the windscreen fig. 28. It is able to detect variations in outside lighting based on the light sensitivity set in the display Menu or the **Uconnect™** 5" or 7" HD system (where provided).



28

FOS0609

Function activation

Turn the ring (A) fig. 29 or fig. 30 (for versions/markets, where provided) to the **AUTO** position.

WARNING The function can only be activated with the ignition device at MAR.

Function deactivation

To deactivate the function, turn the left stalk ring (A) to position .



29

FOS0610



30

FOS0790

LIGHT BEAM DIRECTION

The correct aiming of the headlights is important for the comfort and safety

of not only the driver but all other road users.

This is also covered by a specific rule of the highway code.

The headlights must be correctly aimed to guarantee the best visibility conditions for all drivers while travelling with headlights on.

Contact a Fiat Dealership to have the headlights checked and adjusted.

Check light beam alignment every time the load or its distribution changes.

WARNING When the gas discharge (Xenon) headlights (for versions/markets, where provided) are switched on, normally parabolas and light beam move vertically for about 2 seconds until headlight alignment has stabilised.

HEADLIGHT ALIGNMENT CORRECTOR

This device works with the ignition key in the MAR position and the dipped headlights on.

When the car is loaded, it slopes backwards. This means the headlight beam rises.

In this case, restore the correct alignment by operating buttons **+** and **-** fig. 31.



31

F0S0383

The adjustment positions are shown on the display.

Gas discharge headlights (Xenon headlights) are automatically adjusted. Headlight alignment adjustment is electronic and therefore cannot be manually adjusted using the + and - buttons.

Correct positions depending on the load

Position 0 - one or two people in the front seats.

Position 1 - 4 passengers.

Position 2 - 4 passengers + load in the boot.

Position 3 - driver + maximum permitted load stowed in the boot.

FOG LIGHTS/REAR FOG LIGHTS

(for versions/markets, where provided)

The fog lights can be activated only

when the dipped beam headlights are on.

With the dipped beam headlights on, use the button (A) fig. 32 to turn on the front/rear fog lights, as follows:

- **first press:** turns on the fog lights, the  warning light on the instrument panel will turn on;
- **second press:** turns on the rear fog lights, the  warning light on the instrument panel will turn on;
- **third press:** front/rear fog lights off.

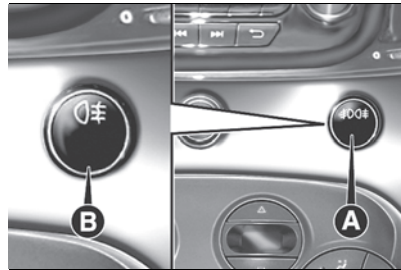

32

F0S0568

REAR FOG LIGHTS

With the dipped beam headlights on, turn on the rear fog lights pressing the button (B) fig. 32. The  warning light on the instrument panel will come on. Press the button again to switch the lights off.

ADJUSTING THE HEADLIGHTS ABROAD

Dipped headlights are adjusted to drive in the country where the vehicle was originally purchased. When travelling in countries with opposite driving direction, to avoid dazzling the drivers on the other side of the road, you need to cover areas of the headlight according to the Highway code of the country you are travelling in.



WARNING

17) The daytime running lights are an alternative to the dipped beam headlights for driving during the daytime in countries where it is compulsory to have lights on during the day, and they are also permitted in those countries where this is not obligatory.

18) Daytime running lights cannot replace dipped beam headlights when driving at night or through tunnels. The use of daytime running lights is governed by the highway code of the country in which you are driving. Comply with legal requirements.



INTERIOR LIGHTS

FRONT CEILING LIGHT

The lens (A) fig. 33 can be set to three positions:

- right side pressed*: light always on;
- left side pressed*: light always off;
- central position (neutral)*: the light switches on and off when the doors are opened or closed.



33

F090429

WARNING Before getting out of the car, make sure that the switch is in the central position: ensure that lights are off with the doors closed in order to avoid draining the conventional battery. On some versions, the lights switch on and off only when the front driver side door is opened or closed.

CEILING LIGHT TIMING

Switching on

Three different switching-on modes are provided:

- when opening one door a three-minute timer will start, which restarts each time a door is opened;
- a timer of about 10 seconds will start when the ignition key is removed within two minutes from turning the engine off;
- a timer of about 10 seconds will start when the doors are opened (either by remote control or key in driver's door).

Switching off

Three modes are provided for switching off:

- when all doors are closed, the 3-minute timer will stop and a 10-second one will start. This timer will stop when the key is turned to MAR;
- when doors are locked (either with remote control or with key on driver side door), the ceiling light switches off.
- the interior lights are switched off in any case after 15 minutes to preserve the conventional battery charge.

WINDOW WASHING

 19) 20)

The right stalk controls windscreen and rear window wiper/washer operation.

WINDSCREEN WIPER / WASHER

 6) 7)

This operates only with the ignition key turned to MAR. The stalk has five different positions (4 speeds) fig. 34:

- A: windscreen wiper off.
- B: intermittent operation.
- C: continuous slow operation.
- D: continuous fast operation.
- E: temporary fast operation (unstable position).

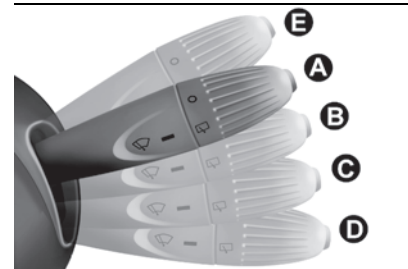

34

F080117

The temporary fast function lasts as long as you manually keep the stalk in that position. The lever returns to position A when it is released, automatically stopping the windscreen wipers.

WINDSCREEN WIPERS WITH AUTOMATIC WIPING

The stalk can be put in four different positions fig. 35:

- A - windscreen wiper stationary (O)
- B - automatic wiping (AUTO)
- C - slow continuous operation (LO)
- D - fast continuous operation (HI)
- E - temporary fast operation (unstable position).

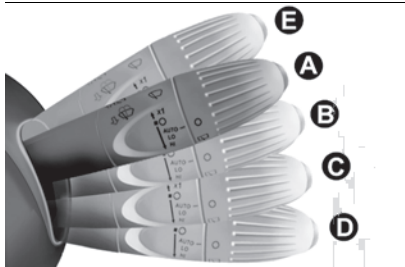

35

F0S0611



In case of direct passage from position (B) to position (E), when the lever is released it returns to position (A).

“Smart washing” function

Pull the stalk towards the steering wheel (unstable position) to operate the windscreen washer.

Keep the lever pulled to activate both the windscreen washer jet and the windscreen wiper with a

single movement; the latter turns on automatically if you keep the lever pulled for more than half a second. The operation of the windscreen wiper terminates several strokes after the stalk is released; a final cleaning stroke several seconds later completes the wiping operation.

REAR WINDOW WIPER / WASHER



This operates only with the ignition key turned to MAR.

Rear Window Wiper

Turn ring (A) fig. 36 from position O to position to operate the rear window wiper as follows:

- in intermittent mode when the windscreen wiper is not operating;
- in synchronous mode (at half the speed of the windscreen wiper) when the windscreen wiper is operating;
- in continuous mode with reverse gear engaged and the control active.

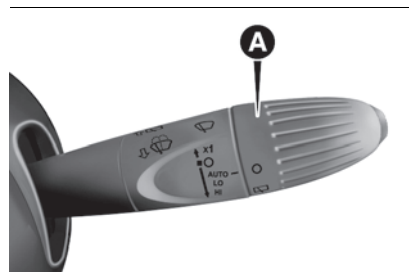

36

F0S0612

With the windscreen wiper on, engaging reverse gear will automatically turn the rear window wiper on, in continuous slow operation. Operation stops when reverse is disengaged.

“Smart washing” function

Pushing the stalk towards the dashboard (spring-return position) will activate the rear window washer.

Keep the stalk pressed, with just one movement, to operate the rear window washer jet and the rear window wiper itself; the latter automatically turns on if you keep the stalk pressed for more than half a second.

The rear window wiper stops operating a few strokes after releasing the stalk; a further "cleaning stroke", after a few seconds, completes the wiping operation.



RAIN SENSOR

(for versions/markets, where provided)
The sensor will be activated when the ignition device is turned to MAR, and will be deactivated in the STOP position. This is a device located behind the interior rear view mirror fig. 37, in contact with the windscreen and can measure the amount of rain and, consequently, manage the automatic wiping mode of the windscreen in accordance with the amount of water on the screen.

WARNING Keep the window clean in the sensor area.



37

F0S0613

AUTOMATIC WIPING

(for versions/markets, where provided)



Activation

The user can choose automatic wiping by moving the right steering wheel stalk by fig. 35 to the AUTO (B) position. The activation of the automatic wiping will be notified to the driver by a single stroke.

Sensitivity Adjustment

The rain sensor sensitivity can be adjusted through the display menu or on the **Uconnect™** 5" or 7" system.

Inhibition

If the starter switch is moved to the STOP position, leaving the right steering wheel stalk in the AUTO (B) position, when the vehicle is next started (starter switch in the MAR position), no wiping cycle to prevent damage to the system if the windscreen is being washed manually or if there is ice on it.

To re-enable the automatic wiping mode:

- Put the right steering wheel stalk in a position other than AUTO and then back to the AUTO position;
- exceed the speed of 5 km/h when the sensor detects rain.

Deactivation

The user can disable automatic wiping by moving the right steering wheel stalk to a position other than AUTO.



WARNING

19) *If the window needs to be cleaned, make sure the device is turned off or the key is on STOP.*

20) *Driving with worn windscreen/rear window wiper blades is a serious risk, because visibility is reduced in bad weather.*



IMPORTANT

6) *Never use the screen wiper to remove layers of snow or ice from the windscreen glass. In such conditions, the wiper may be subjected to excessive stress and the motor cut-out switch, which prevents operation for a few seconds, may intervene. If operation is not restored, contact a Fiat Dealership.*

7) *Do not operate the windscreen wiper with the blades lifted from the windscreen.*

8) *Do not activate the rain sensor when washing the car in an automatic car wash.*

9) *Do not use the rear window wiper to remove layers of snow or ice. In such conditions, the wiper may be subjected to excessive stress and the motor cut-out switch, which prevents operation for a few seconds, may intervene. If operation is not restored, contact a Fiat Dealership.*

10) *Make sure the device is switched off if there is ice on the windscreen glass.*

CLIMATE CONTROL SYSTEM



MANUAL CLIMATE CONTROL SYSTEM

(for versions/markets, where provided)

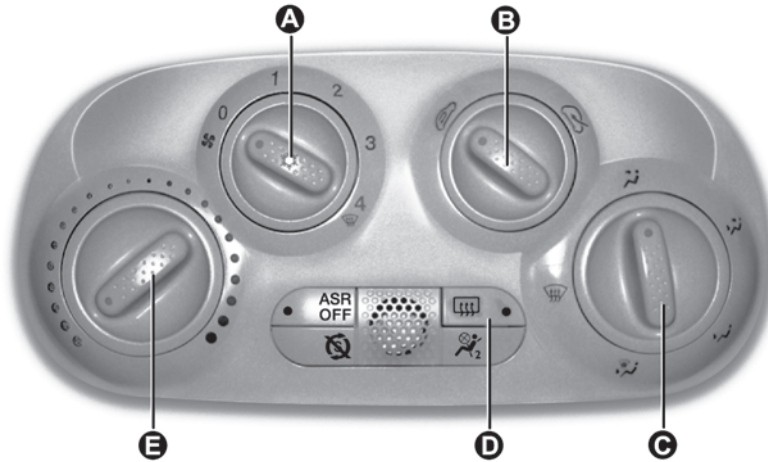

38

F0S0594



A - fan knob and climate control system compressor button.

B - recirculation control / air intake from outside knob.

C - air distribution knob:

 air flow to central and side dashboard vents to ventilate the chest and the face in warm weather;

 distribution between foot area diffusers (warmest air) and dashboard diffusers (coolest air);

 towards the footwell vents.

Due to the natural tendency of heat to spread upwards, this type of distribution warms the passenger compartment up as quickly as possible, providing an immediate feeling of warmth;

 distribution between footwell vents and windscreen/front side window vents. This type of distribution achieves effective heating of the passenger compartment and prevents the windows from misting up;

 air flow to the windscreen and front side window vents to demist or defrost them.

D - heated rear windscreen button.

E - temperature adjustment knob.

Press the knob (A) fig. 38 to turn the climate control system on and off.

NOTE Optimal cooling/heating of the passenger compartment may not be guaranteed together with Start&Stop. To prioritise the operation of the climate control system, deactivate the Start&Stop function.

Note To stop the air flow from the vents turn the knob to 0.

WARNING It is advisable to switch the air recirculation on whilst queueing or in tunnels to prevent the introduction of polluted air. However, it is better not to use the function for long periods, particularly if there are many people on board, to prevent the windows from misting.

AIR RECIRCULATION

(knob (B) fig. 38)

 internal air recirculation

 air intake from outside

Use air recirculation for maximum climate control performance. To demist the windows, set the recirculation control to .

WARNING In warm-humid weather conditions, using cold air on the windscreen may cause external condensation, which could limit visibility.

FAST WINDSCREEN AND FRONT SIDE WINDOW DEMISTING/DEFROSTING (MAX-DEF)

Proceed as follows:

turn knob (E) to the red section;

turn knob (B) to .

turn knob (C) to .

turn knob (A) to 4  (max. fan speed).

WARNING The climate control system is very useful for speeding up demisting since it dehumidifies the air. Adjust the controls as described above and press knob (A) to switch the climate control system on: the LED on the knob will light up.

ADDITIONAL HEATER

(for versions/markets, where provided)

The additional heater switches on automatically according to the environmental conditions and with engine started when the temperature of the engine coolant is low.

It always switches off automatically when the required passenger compartment comfort conditions are achieved and when the engine coolant temperature is hot.

Warnings

The heater only operates if the outside temperature and coolant temperature are low.

The heater will not activate if the conventional battery voltage is too low.

SYSTEM SERVICING

In winter, the climate control system must be turned on at least once a month for about 10 minutes. Have the system inspected at a Fiat Dealership before the summer.



AUTOMATIC CLIMATE CONTROL SYSTEM

(for versions/markets, where provided)

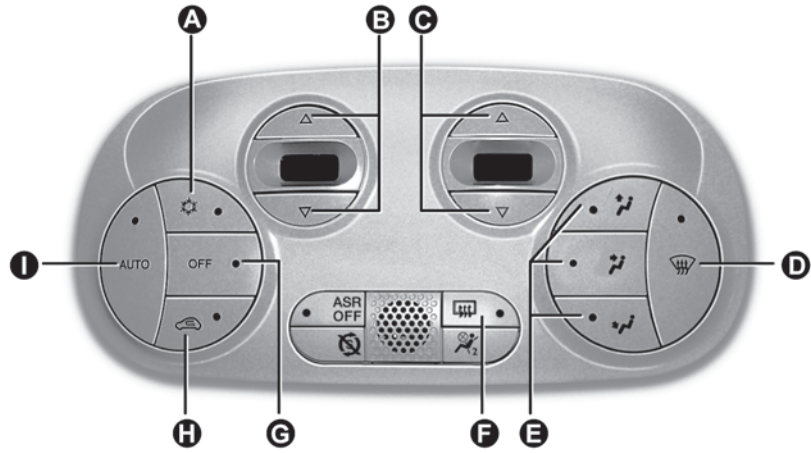

A - Climate control system compressor on/off

B - Adjustment of temperature inside the passenger compartment.

□ Δ : increase required temperature to the HI value (maximum heating).

□ ∇ : increase required temperature to the LO value (maximum cooling).

C - fan speed adjustment.

When the buttons Δ or ∇ are pressed, the fan speed, shown by the switching on of lit bars on the display, increases or decreases.

D - Button for switching fast front window demisting/defrosting on and off.

WARNING The function remains active for approximately 3 minutes after the coolant temperature exceeds 50°C.

WARNING In warm-humid weather conditions, using cold air on the windscreen may cause external condensation, which could limit visibility.

E - Passenger compartment air distribution.



By pressing the buttons, one of the five possible air flow distribution patterns can be selected:



□  air flow to the windscreen and front side window diffusers to demist or defrost them;

□  air flow to central and side dashboard vents to ventilate the chest and the face in warm weather;

□  towards the footwell diffusers.

Due to the natural tendency of heat to spread upwards, this type of distribution warms the passenger compartment up as quickly as possible, providing an immediate feeling of warmth;

□  +  distribution between feet area diffusers (warmest air) and dashboard diffusers (coolest air);

□  +  distribution between the footwell diffusers and the windscreen and front side window diffusers. This type of distribution achieves effective heating of the passenger compartment and prevents the windows from misting up.

F - Heated rear windscreen on/off button.

WARNING Do not apply stickers on the inside of the rear window over the heating filaments to avoid damage.

G - Switching off

H - Internal air recirculation on/off button

It is advisable to switch the internal air recirculation on whilst queuing or in tunnels to prevent the introduction of polluted air.

LED on button ON = recirculation ON.
LED on button OFF = recirculation OFF.

WARNING It is inadvisable to use air recirculation when the outside temperature is low, since the windows could mist rapidly.

I - Automatic climate control system on/off

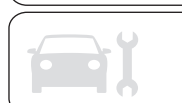

**IMPORTANT**

11) *Never use R12 or R134a coolant, which is not compatible with climate control system components.*

**IMPORTANT**

2) *The system uses R1234yf coolant, which is compatible with the laws in force in the countries where the vehicle is sold. When charging, only use the gas indicated on the dedicated plate in the engine compartment. The use of other coolants affects the efficiency and condition of the system. The lubricant used for the compressor is also strictly linked to the type of cooling gas, please refer to a Fiat Dealership.*

ELECTRIC WINDOWS

 21) 22)

These operate when the ignition key is turned to MAR and for about two minutes after turning the key to STOP or removing it. The electric window control buttons are located beside the gear lever fig. 40 and activate:

(A) Opening/closing of the left window.
(B) Opening/closing of the right window.



40

F0S0590

Hold the button pressed for a few seconds to wind the window down automatically or hold it pressed to wind the window up automatically (with the key at MAR only).



WARNING

21) *Improper use of the electric windows can be dangerous. Before and during operation, always check that nobody is exposed to the risk of being injured either directly by the moving window or through objects getting caught or hit by it. When leaving the car, always remove the ignition key to avoid the risk of injury for people still on board due to accidental operation of the electric windows.*

22) *When leaving the vehicle, always remove the ignition key to avoid the risk of injury for people still on board due to accidental operation of the electric windows.*

ROOF

FIXED GLASS SUNROOF

(for versions/markets, where provided)

The roof comprises a wide fixed glass panel and a manually-operated sunshade. The blind can be used in the "all closed" or "all open" positions.

To open the blind, grab the handle, press the tooth (A) fig. 41 and move it to the completely open position.

To close it, grab the handle and move the blind to the closing position until tooth A is attached.



41

F0S0097

SUNROOF

(for versions/markets, where provided)

 23)

 12) 13) 14)

To move the sunshade, follow the instructions in "fixed glass roof".

Opening

Hold button (A) located near the front ceiling light pressed fig. 42, to move the roof to "spoiler" position.

With the roof open in "spoiler" position, hold button (A) pressed again to move the roof to all open position. The roof will stop in the position reached when the button is released.



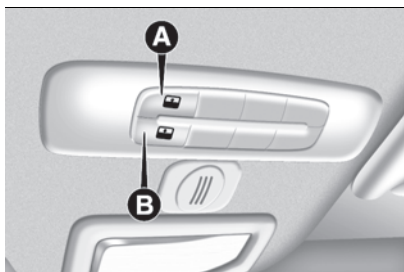

42

F0S0096

Closing

Press button (B) fig. 42 from the all open position: the front glass panel will move into the "spoiler" position. The roof will stop in the position reached when the button is released. Hold button (B) pressed again to reach the all closed position of the roof.

ANTI-PINCH DEVICE

The sunroof has an anti-pinch safety system capable of detecting the presence of an obstacle whilst the roof is closing. When this happens, the system stops and the movement of the roof is immediately reversed.

INITIALISATION PROCEDURE

The sunroof must be reinitialised after disconnecting the conventional battery or if the corresponding protective fuse is blown. Proceed as follows:

- keep the button (B) fig. 42 pressed so that the roof closes completely in stages
- after full closing, wait for the sunroof motor to stop.

EMERGENCY OPERATION

If the electrical device for moving the roof fails, the sunroof can be moved manually proceeding as described below:



43

F0S0098

- for manual activation remove the protective cap (A) fig. 43 from its housing which is located on the internal covering behind the sunshade
- take the hex wrench provided from the tool bag in the boot
- insert the key provided into housing (B) fig. 43 and turn it clockwise to open the roof or anticlockwise to close the roof.



WARNING

23) When leaving the car (equipped with mechanical key with a remote control), always remove the key from the starter switch to avoid the risk of injury to those still inside the car due to accidental operation of the sunroof. Improper use of the roof can be dangerous. Before and during operation, always check that no-one is exposed to the risk of being injured by the moving sunroof or by objects getting caught or hit by it.



IMPORTANT

- 12)** Do not open the sunroof if a transverse roof rack is fitted. Do not open the sunroof if there is snow or ice on it: you may damage it.
- 13)** Do not open the sunroof if there is snow or ice on it: you may damage it.
- 14)** Be careful not to hit objects on the roof rack when you open the tailgate.

SOFT TOP

TIP

- it is advisable to close the soft top when the car is parked. The closed soft top effectively protects the car from bad weather and from theft;
- it is advisable to put valuables in the boot and lock the lid even when the soft top is closed.

SOFT TOP MOVEMENT

 24) 25) 26)

 15) 16) 17)

WARNING The motor may overheat if the soft top is repeatedly operated within a short space of time, thus causing the overheating protection to inhibit system operation. Wait for a minute and repeat.

Opening from roof fully closed position

Press the button (A) fig. 44 once to open the roof automatically to the horizontal opening position (spoiler position). If one of the two buttons is pressed before reaching the spoiler position, the roof may stop in an intermediate horizontal opening position.



44

F0S0542

Opening from top in intermediate horizontal position

From the horizontal intermediate position press the button (A) fig. 44 to move the roof automatically to the horizontal all open position (spoiler position) fig. 45.



45

F0S0546

Opening roof from spoiler to all open position

From the spoiler position, pressing the (A) fig. 44 button once, the roof

goes automatically to the full opening position (vertical opening) fig. 46.



46

F0S0545

If one of the two buttons is pressed before the final position is reached, the soft top will stop and move back to the initial position (spoiler position).

WARNING The vertical opening will be inhibited when the tailgate is open.

WARNING If the soft top locks during its movement, it may lose the position; in this case, you should carry out a complete opening / closing cycle.

Closing the roof from roof fully open position

Press the button (B) fig. 44 once to automatically close the roof to spoiler position (vertical section closing). If one of the two buttons is pressed before the spoiler position is reached, the



roof will stop and movement will be reversed, moving to the initial position (all open).

Initial condition: from spoiler position to top all closed

Press the “one-touch” button (B) fig. 44 in spoiler position to bring the top automatically to safety position (approximately 25 cm from fully closed position). If one of the two buttons is pressed before the stop position is reached, the soft top may stop in an intermediate horizontal open position. NOTE The roof will not automatically close completely; keep button (B) fig. 44 pressed to close the roof completely.

The roof will stop instantly if the button is released before the all closed position is reached.

Initial condition: from intermediate position to roof all closed

Press the button (B) fig. 44 in the horizontal intermediate position to bring the roof automatically to the safety position (approximately 25 cm from horizontal all closed position). Keep the button (B) fig. 44 pressed to close the roof completely.

The roof will stop instantly if the button is released before the all closed position is reached.

Opening the tailgate with top all open

Press the tailgate opening button (A) fig. 47 once to automatically close the roof to spoiler position. The tailgate can be opened in spoiler position.



47

F0S0101

OPERATION BY MEANS OF REMOTE CONTROL

The remote control can only be used with the engine off and the doors closed.

NOTE The remote control can be used to open the roof to the horizontal open position (spoiler position).

Continuously pressing the “release” button (A) fig. 48, the roof opens and stops in any position when the button is released.

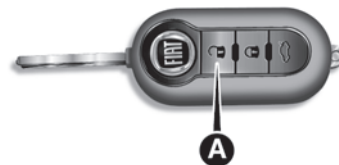

48

F0S0543

WARNINGS

- ❑ The horizontal and vertical parts of the soft top can be operated at any speed lower than 100 and 80 km/h respectively.
- ❑ The soft top can be operated at any temperature in the range from -18 to +80 °C.
- ❑ It is recommended to have the engine running always when opening or closing the soft top.
- ❑ If required, remove the conventional battery with the soft top either open or closed, but NOT while it is moving.
- ❑ Do not fix roof racks to the soft top and do not travel with objects resting on the open top.
- ❑ The activation of the heated rear windscreen, upon request by the user, is carried out only if the soft top is completely closed. If the soft top is closed incorrectly, the heated rear window will not function and the

corresponding warning light will not turn on.

❑ When the soft top is opened using the relevant control, if the heated rear windscreen had been engaged it is automatically deactivated and the warning light switches off

❑ Do not remove ice from the soft top with a sharp item.

❑ To prevent damage, do not use scrapers or sprays to remove ice from the heated rear window.

❑ Do not put objects on the soft top: they could fall if the it is operated, causing damage and injury.

❑ It is advisable to cover the soft top with a protective sheet if the car is left parked in the open for a long time.

❑ Do not keep the soft top folded for a long time: this could cause folds and creases in the fabric.

❑ Before moving the soft top, check that there is enough room to carry out the operation and that there are no obstacles or people close to its moving parts.

❑ The cooled air flow into the passenger compartment may decrease if the automatic climate control system is on and the soft top is not completely closed.

❑ With the soft top open and the car travelling, the voice recognition system may not recognise voice commands

because of the background noise: with the soft top closed and at a high speed, the voice function for number dialling may not be recognised.

EMERGENCY OPERATION

If the buttons fail, the soft top can be moved manually proceeding as described below:

❑ take the key (A) fig. 49 provided and located in the boot in combination with the tool bag or the Fix&Go kit;

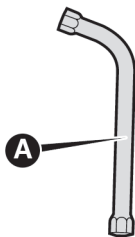

49

F0S0547

❑ insert the key provided in position (A), visible from inside the boot beneath the parcel shelf at the point shown in fig. 50;

❑ turn: clockwise to open the soft top; anticlockwise to close it.

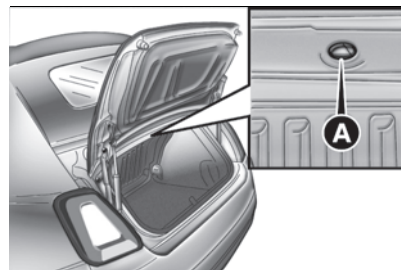

50

F0S0544

If the tailgate fails to open because the conventional battery is flat, or following a fault in the tailgate electric lock, perform the emergency tailgate opening procedure as described in the "Boot" chapter of the "Knowing your car" section, then manually move the soft top as described above.

To restore the automatic movement conditions, apply to Fiat Dealership.

INITIALISATION PROCEDURE

The soft top must be reinitialised after disconnecting the conventional battery or if the corresponding protective fuse is blown.

Proceed as follows:

❑ with the ignition device at MAR, keep the opening button pressed until the soft top is completely open;



- ❑ when the soft top is completely open, keep the button pressed for at least 2 seconds;
- ❑ keep the closing button pressed until the soft top is completely closed;
- ❑ once the all closed position has been reached, continue to press the button until the soft top makes a full opening and closing run.

If the soft top is already initialized, the user can perform a new initialisation by the following steps:

- ❑ keep the opening button pressed until the soft top is completely open;
- ❑ when the soft top is completely open, keep the button pressed for at least 30 seconds (to force the loss of initialisation);
- ❑ keep the closing button pressed until the soft top is completely closed;
- ❑ once the all closed position has been reached, continue to press the button until the soft top makes a full opening and closing run.

WIND STOP

To use the Wind Stop fig. 51:

- ❑ Release the backrest of the rear seat (single or split);
- ❑ attach the Wind Stop by inserting the central part inside the rear screen guard, with the concave part in the direction of the passenger, as shown in fig. 51;

- ❑ re-position the backrest correctly: the Wind Stop is locked between the seat and parcel shelf.

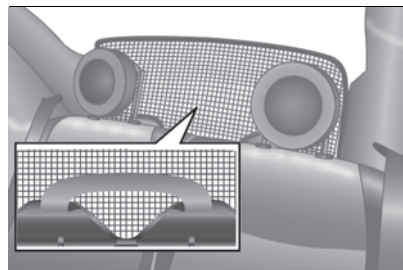

51

FOS0550

FRONT SPOILER

The car is provided with a front spoiler which can be raised to improve aerodynamic comfort inside the passenger compartment.

To lift the spoiler, release the catch by means of the slider (A) moving it to position (2) as shown in fig. 52

With the spoiler raised, take care not to move the slider (A) from position (1) to position (2).

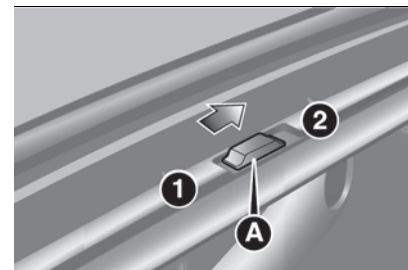

52

FOS0548

To lower the spoiler, press and move the slider to position fig. 53 to lock it once the slider's catch is positioned inside its housing (1) fig. 52.

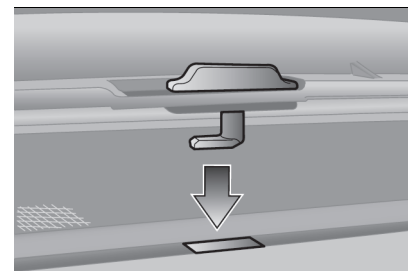

53

FOS0549

It is advisable to raise the spoiler when the horizontal segment of the top is open and at speeds faster than 50 km/h.

With the top completely open, it is advisable to keep the spoiler lowered to limit wind noise inside the passenger compartment.

Raising the spoiler will reduce the flow of air to the rear seats.

WASHING/CLEANING THE SOFT TOP

 18) 19) 20) 21) 22) 23) 24) 25)

Use of specific products is recommended for washing the soft top cloth.

The soft top fabric is treated with a special water-repellent, waterproof product. The water-repellent properties will degrade in time with exposure to the weather elements. Observe the following instructions.

Remove as much dirt from the surface of the soft top with a soft brush or vacuum cleaning before washing it. This operation will considerably improve the final result.

In lack of specific products, use water and neutral soap applied with a sponge (preferably in the shade) for washing. Rinse the soft top with clean water after having eliminated all the stains.

Hand washing is recommended; modern automatic washing systems equipped with soft brushes which do not apply excessive pressure and employ specific soft top products may be used.

Leave the car in the shade after washing avoiding direct sunlight.

Waterproofing the soft top

Use specific waterproofing products for fabric soft tops.

Interior soft top fabric

Remove dust with a soft brush. Avoid using hard brushes made of synthetic material to prevent damaging the fabric beyond repair.

Clean the surface with a microfibre cloth or soft sponge dipped in a solution of water and neutral soap. Clean the entire surface, including the zones where cleaning is not needed, to prevent staining.

Use common, care mild stain removers that can be purchased from car cleaning product ranges to remove more stubborn stains. Apply by blotting (never rubbing) directly on the area of the stain.



WARNING

24) Keep hands away from the top mechanism while opening and closing the top or if the top stops in a position before completing the cycle to prevent damage and injury.

25) Keep children away from the area in which the top is folding during opening or closing operations.

26) When leaving the car, always remove the key from the ignition device to avoid the risk of injury due to accidental

operation of the soft top: improper use of the roof can be dangerous. Before and during operation, always check that no-one is at risk of being injured by the moving soft top roof or by objects getting caught and dragged by it.



IMPORTANT

15) Never open the top in presence of snow or ice to prevent damage.

16) Do not place objects on the rear window shelf to prevent damage while the top is closing.

17) Loads may not be secured on the roof.
18) Bird droppings and plant resins must be washed off immediately and thoroughly as the acid they contain is particularly aggressive.

19) Never use high-pressure washing systems.

20) When using steam washers or high-pressure water washers, maintain a suitable distance and do not exceed a maximum temperature of 60°C. Damage, alterations and water infiltration may occur if the distance is too small and the pressure is too high.

21) If a water jet is used, direct away from the edges of the fabric and the rear window frame to prevent water infiltration.

22) Never use alcohol, petrol, chemical products, detergents, stain removers, wax, solvents and "wash and polish" products.

23) Rinse immediately to remove soap to prevent stains. Repeat the operation if needed.

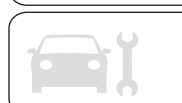

24) Follow the instructions on the waterproofing product container for perfect results.

25) The rubber seals on the soft top must be cleaned exclusively with water. If you notice that this trim is dry or is sticking, apply talcum powder or products specifically for rubber trim (silicone spray).

BOOT

 27) 28) 29)

ELECTRIC HANDLE (SOFT TOUCH)

The tailgate can be opened at any time if the doors are unlocked.

To open it, enable the handle, opening one of the front doors or unlocking the doors with the remote control or using the key without remote control.

- Operate the electric handle (A) fig. 54 to open the tailgate.
- To release the lock manually, use the metal insert of the ignition key.
- To release the lock with the remote control, press button .
- To close, use the handle located inside the tailgate.
- If the tailgate is not shut properly the dedicated instrument panel or colour display warning light (where provided) will switch on.



54

F0S0101

Opening the tailgate with soft top all open

Pressing the tailgate opening one-touch button (A) fig. 54 to automatically close the soft top to spoiler position. The tailgate can be opened in spoiler position.

 30)

EMERGENCY TAILGATE OPENING

To open the tailgate from the inside if the conventional battery in the car is flat or the electric lock on the tailgate is faulty, proceed as follows:

- take out the rear head restraints;
- tilt the backrests;
- to unlock the tailgate mechanically, working from the inside of the luggage compartment, use lever A fig. 55.



55

F0S0135



WARNING

27) Never exceed the maximum permitted load in the boot; see the "Technical specifications" section. Also make sure that the objects you place in the boot have been properly secured, to avoid them from being thrown forward consequent to sharp braking and injuring your passengers.

28) Be careful not to hit objects on the roof rack when you open the tailgate.

29) If you are travelling in areas with few filling stations and you want to transport fuel in a spare tank, comply with the law by using only an approved, suitably secured tank. In the event of a collision the fire risk is increased all the same.

30) Do not drive with the tailgate open as exhaust fumes may enter the passenger compartment.

BONNET

 31) 32) 33) 34) 35)

OPENING

Proceed as follows:

□ pull the lever (A) fig. 56 in the direction indicated by the arrow;

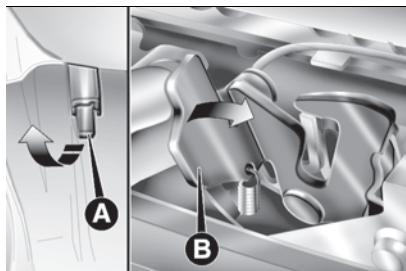

56

F0S0045

□ move the release lever B in the direction indicated by the arrow, and raise the bonnet; locate the safety rod; □ Insert the safety rod in the seat (A) fig. 57 integral to the bonnet.

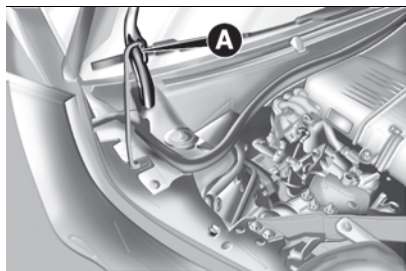

57

F0S0616

CLOSING

To close the bonnet, remove the bonnet stay and put it back in its own locking device, slowly lower the bonnet to about 20 cm from the engine compartment, then let it drop into position and check that it is completely closed. If not, repeat the procedure.



WARNING

31) *The bonnet may drop suddenly if the supporting rod is not positioned correctly. Only perform these operations when the car is stationary.*

32) *Be careful working inside engine compartment when the engine is hot to avoid burning yourself. Do not place your hands near the engine fan as it may be activated even when the key is removed. Wait until the engine has cooled.*

33) *Be very careful not to allow scarves, neck ties and other loose articles of clothing from touching, even accidentally, any moving parts. This may cause the clothing to be pulled into the part, resulting in serious risk to the wearer.*

34) *For safety reasons, the bonnet must always be properly closed while driving. Therefore, make sure that the bonnet is properly closed and that the lock is engaged. If you discover that the bonnet is not perfectly closed while driving, stop immediately and close the bonnet in the correct manner.*

35) *Use both hands to lift the bonnet. Before lifting, check that the windscreen*

wiper arms are not raised from the windscreen, that the vehicle is stationary and that the handbrake is engaged.

INTERIOR FITTINGS

CIGARETTE LIGHTER

(for versions/markets, where provided)

It is located on the left side of the central tunnel next to the bottle holder fig. 58. Press button (A) to activate the cigar lighter.

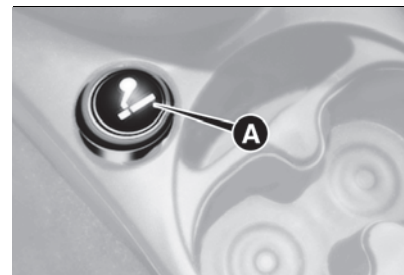

58

F0S0663

After a few seconds the button goes back to its initial position and the cigar lighter is ready for use.

WARNING Always check that the cigarette lighter is switched off.

WARNING Do not connect devices with power higher than 180W to the



socket. Do not damage the socket by using unsuitable adaptors.



36)

SUN VISORS

They are located at the sides of the interior rear-view mirror. They can be adjusted forwards and sideways fig. 59.

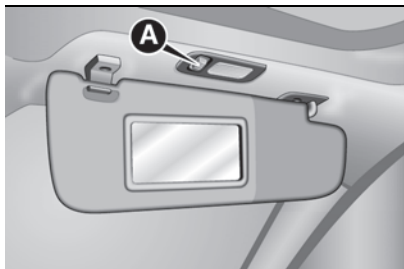

59

F0S0038

The passenger side sun visor includes a courtesy mirror, lighted by a specific light that can be switched on using the button (A) fig. 59.

The driver and passenger side sun visors include document pockets



37)

GLOVE COMPARTMENT

(for versions/markets, where provided)

It is located on the dashboard, passenger side.

To open the compartment, use handle (A) fig. 60.



38)

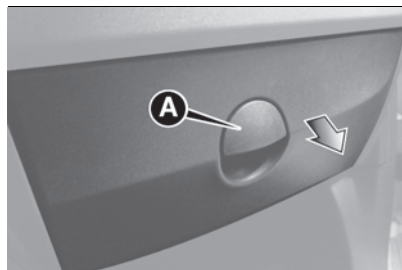

60

F0S0600

CUP/BOTTLE HOLDERS

On the central tunnel there are two cup/can holders for the front seats and two for the rear seats.

POWER SOCKET

(for versions/markets, where provided)

It is located on the left side of the central tunnel, near the bottle holder, and is powered with the ignition key in the MAR position.

Open protective cover to use the socket (A) fig. 61.

Correct operation is ensured only if the connected accessories are provided with approved standard plugs, present on all Lineaccessori MOPAR® components.

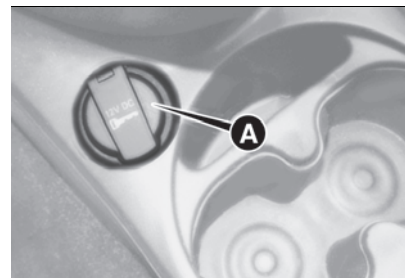

61

F0S0664

WARNING With the engine off and ignition key turned to MAR, extended use (i.e. for over one hour) of accessories that drain a lot of power may reduce the efficiency of the conventional battery and eventually prevent the engine from starting.



39)

USB INPUT

(for versions/markets, where provided)

There is a USB input on the central tunnel, for connecting a smartphone or Pen Drive as an audio source for the **Uconnect™** multimedia system.

WARNING After using a USB charging port, we recommend disconnecting the device (smartphone), always removing the cable from the port of the car first, never from the device. Cables left flying or connected incorrectly could

compromise correct recharging and/or the USB socket condition.

NOTE The USB port handles data transmission from the Pen Drive/Smartphone, etc. and slow recharging of an external device, which is not guaranteed as it depends on the device type/brand.



WARNING

36) *The cigar lighter becomes very hot. Handle it with caution and do not allow it to be used by children to avoid the risk of fire or burns.*

37) *On both sides of the passenger side sun visor there is a label remembering that it is compulsory to deactivate the airbags if a rearward facing child restraint system is fitted. Always comply with the instructions on the label.*

38) *Never travel with the glove compartment open: it could injure the passenger in the event of an accident.*

39) *Accessories with a maximum power of 180 W (maximum electrical input 15 A) can be connected to the socket.*

ROOF RACK/SKI RACK

 40) 41) 42)

 26)

FASTENERS

The fasteners are located in the area indicated in fig. 62.

To use the front fasteners, remove the cap (A) fig. 62, accessible with the door open.



62

F0S0136

The rear fixing areas (B) can be found according to measurements shown in fig. 63. Lineaccessori MOPAR® a specific roof rack/ski rack for the tailgate.

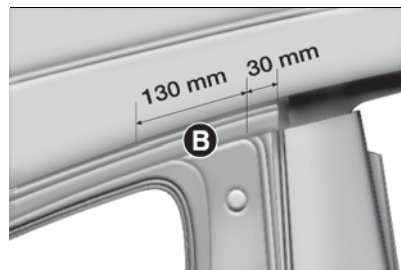

63

F0S0152

WARNING Follow the instructions contained in the assembly kit carefully. Assembly must be performed by qualified personnel.



WARNING

40) *Fully comply with the regulations in force concerning maximum clearance. Never exceed the maximum permitted loads; see chapter "Technical specifications".*

41) *Evenly distribute the load and take into account, when driving, the increased responsiveness of the car to side wind. After travelling for a few kilometres, check to ensure that the fixing screws for the attachments are well tightened.*

42) *Before driving, make sure that the transversal bars have been fitted properly.*



**IMPORTANT**

26) *The use of transversal bars on longitudinal ones prevents the use of the sunroof, because the latter, while opening, interferes with the bars. Therefore do not move the sunroof if transversal bars have been fitted.*

VERSION WITH LPG SYSTEM



27)

INTRODUCTION

The "LPG" version of the car features two fuel systems, one for petrol and one for LPG. Like the petrol system, the LPG system is timed, sequential multipoint type with special injectors.

PASSIVE SAFETY/ACTIVE SAFETY

43) 44)



28) 29)

Passive safety

The car has the same passive safety specifications as other versions. In particular, the tank mountings (located in the spare wheel housing) have been designed to exceed the Fiat safety standards for impact tests.

Active safety

The car has the same active safety specifications as other versions.

Although the LPG system has numerous safety features, it is advisable to proceed as follows every time the car is not in use for a long period or moved in an emergency as a result of a fault or accident:

unscrew the fixing devices (A) fig. 64, then remove the cover (B);

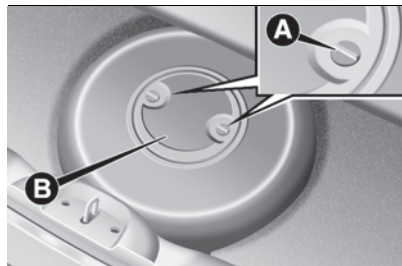

64

F0S0541

close the LPG cock by rotating the knurled ring nut C fig. 65 clockwise;

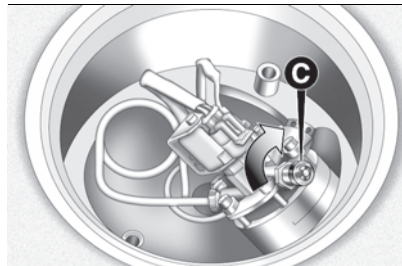

65

F0S0531

refit the cover and retighten the fastening devices.

LPG TANK

30)

The car has a (pressurised) tank (A) fig. 66 for collecting LPG in a liquid state. It is toroidal and is located in the spare wheel compartment with suitable protection.



66

F0S0533

The LPG in the tank is always in both a liquid and gaseous state, in physical balance between the two stages. The liquid, which cannot be compressed, dilates by around 0.25% for each increase in temperature of one degree. For this reason a suitable free gap allowing the increase in volume of the liquid for all expected temperature increases is guaranteed (e.g. car parked in the sunshine in summer), without compromising tank integrity.

A safety valve has been fitted to this end, to automatically limit the refilling of the tank (during refuelling) to a maximum level of 80% (liquid) of its total capacity.

LPG tank certification

The LPG tank is certified in accordance with the regulations in force. In Italy, the tank has a life of 10 years starting from the car registration date. If the vehicle has been registered in a country other than Italy, the duration and the testing/inspection procedures of the LPG tank can vary depending on the national laws of that country. In all case, when the time limit for your country has expired, go to a Fiat Dealership to have the tank replaced. The tank identification data are printed on the tank, under the multivalve unit:

- ❑ type-approval country identification and type-approval number;
- ❑ type of gas for which it is designed (LPG);
- ❑ name of tank manufacturer;
- ❑ tank commissioning pressure (30 bar);
- ❑ maximum refilling percentage (80%);
- ❑ tank dimensions;
- ❑ rated tank capacity in litres;
- ❑ tank manufacture date (month/year);
- ❑ tank serial number.

SOLENOID VALVES AND SAFETY DEVICES

The system has a solenoid valve located on the pressure reduction unit and a solenoid valve fitted inside the multivalve stack on the tank.

The main function of these solenoid valves is to interrupt/allow the flow of LPG to the supply circuit.

The solenoid valves are open when:

- ❑ a request to run on LPG has been made;
- ❑ the optimum engine running conditions are satisfied (engine coolant temperature, minimum revs level) for running on LPG;
- ❑ there is enough LPG in the tank for operation; The multivalve unit on the tank includes:
 - ❑ a valve that automatically stops the refuelling of LPG when the maximum permitted filling level is reached (80% of the total tank capacity);
 - ❑ a flow limiter which, if a piping is broken, prevents the complete and sudden escape of LPG;
 - ❑ a check valve preventing LPG back-flow to the filler;
 - ❑ a safety solenoid valve on the LPG supply line for enabling or preventing the flow of gas towards the pressure reducer;

- ❑ a manual valve, positioned upstream of the solenoid valve for bypassing the LPG system for servicing operations;
- ❑ a melting pad which, in the case of overheating (temperature above 120°C), totally eliminates the danger of excess pressure, releasing the LPG in the tank to the outside as quickly as possible in a controlled manner;
- ❑ an analogue level gauge for LPG in the tank.

LPG/PETROL SWITCH

 45)

 31)

It is located in the centre tunnel fig. 67 and includes:

- ❑ (A) LPG/petrol switch;
- ❑ (B) indicator for LPG quantity; 5 LEDs, four green and one orange to indicate reserve. The orange LED turns on when only one green LED is on.
- ❑ (C) petrol operating mode indicator: orange LED next to the switch (A). This function is controlled directly by the LPG control unit.
- ❑ (D) LPG operating mode indicator: green LED next to the switch (A). This function is controlled directly by the LPG control unit.



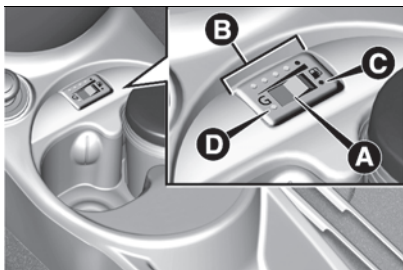

67

F0S0673

WARNING If the ignition key is turned to MAR, all the device LEDs will stay on for approximately 4 seconds (check function). Engine starting always occurs on petrol; then, depending on the position of the switch (A) fig. 67 the following occurs:

- the switch (A) pressed on the right side (identified by the  symbol) indicates petrol operation with activation of the associated amber LED C;
- switch (A) pressed on the left side (identified by the symbol G) indicates LPG operation with activation of the associated green LED (D).

Five LEDs (B) (one amber and four green) on the top part of the switch display the amount of LPG in the cylinders. If the LPG runs out, the system automatically switches to petrol: the orange LED (C) next to the switch comes on and the green LED

(D) indicating LPG operation goes off. When the car is refuelled with LPG after a standard start-up on petrol, the fuel system automatically returns to LPG: the orange LED (C) next to the switch goes off and the green LED (D) for LPG operation turns on.

If you specifically wish to run on petrol, press the switch (A) on the right-hand side. The amber LED (C) next to the switch will turn on to indicate that switching has taken place (the LPG fuel system has been entirely disabled).

The fuel supply can only be returned to LPG by operating the switch (A) again, green LED (D) next to the switch, will turn on to indicate that switching has taken place.

In addition, when starting at outside temperatures below approximately -10°C , the switching times from petrol to LPG increase to allow the pressure regulator/reduction unit to heat up.

WARNING If switching takes place during acceleration or pick-up, there may be a brief drop in power.

REFUELLING



46)



32)

Maximum refuelling capacity (including reserve): 30.5 litres. The figure already

takes into account the 80% tank filling limit and the residual fluid required for priming and the maximum permitted capacity. In addition, after different refuelling processes, this figure may vary due to differences between the network pump supply pressures, pumps having different supply/locking features, tank not completely run out of fuel.

Note that when using a fuel such as LPG, the range is very variable because, in addition to the vehicle driving and maintenance conditions, it also depends on the composition of the gas which may vary, not only seasonally, but also from supplier to supplier. LPG is, in effect, a composition of gas (butane and propane) mixed in a way that may not be standardised.

The trip computer data concerning average consumption, instantaneous consumption and range are not available for this version.

WARNING In order to avoid inconsistent information by the LPG gauge, it is recommended to refill with at least 10 litres each time.

WARNING Only use LPG for motor vehicles.



WARNING

43) Note that in some countries (including Italy) there are legal restrictions in force for parking/ garaging motor vehicles fuelled by gas that is denser than air; LPG comes under this category.

44) If gas is smelt, switch from methane operation to petrol operation and immediately go to a Fiat Dealerships to have the vehicle checked and possible system faults supply excluded.

45) Do not switch between the two operating modes whilst starting the engine.

46) The LPG supply system is equipped with a "consumption" function linked to the LED display of LPG level on the switch; this function activates only after a consistent variation in fuel level has been detected. It is therefore advisable to fill up with fuel at the first LPG refuelling to obtain a more "precise" indication of the level.



IMPORTANT

27) The system operates at temperatures ranging between -20°C and 100°C.

28) The car is equipped with a specifically designed gaseous LPG injection system: it is therefore absolutely forbidden to alter the configuration of the system or its components. The use of other components or materials could cause malfunctions and lead to a reduction in safety; therefore, in the case of problems, contact a Fiat Dealership. When towing or lifting the car, follow the instructions in the

main handbook under the "Towing the car" paragraph to prevent damage to the gas system parts.

29) When painting in an oven, the LPG tank must be removed from the car and later refitted by a Fiat Dealership. Although the LPG system has numerous safety features, it is advisable to proceed as follows every time the car is not in use for a long period or moved in an emergency as a result of a breakdown or accident: unscrew the fastening devices (A) fig. 64, then remove the cover (B). Close the LPG cock by rotating the ring nut (C) fig. 65 clockwise. Refit the cover and retighten the fastening devices.

30) Periodically (at least once every six months), it is advisable to let the LPG in the tank run out and, at the next refuelling, check that it does not exceed the maximum capacity of 30.5 litres (reserve included) (with a tolerance of 2 litres excess) (see instructions in the "Capacities" paragraph). If the level is above 30.5 litres (reserve included) contact a Fiat Dealership immediately.

31) In particular usage conditions, such as starting and operation at low ambient temperature or LPG supply with low propane content, the system may switch temporarily to petrol operation, without a visual indication of switching on the instrument panel. In the event of low LPG levels in the tank or request for high performance (e.g. overtaking, car fully laden, steep hills) the system may automatically switch to petrol operation to guarantee the engine power requested; the green warning light on the instrument panel switches on to indicate this. When the above conditions are no

longer present, the system automatically restores LPG operating mode; the green warning light switches off. To achieve the automatic switching described above, make sure that there is always enough fuel in the petrol tank.

32) It is strictly forbidden to use any additive in the LPG.

RED SPECIAL SERIES

(where provided)

Some components of the car underwent antimicrobial treatments, as detailed below. No specific precautions are required for the normal use of the car and components treated with biocide substances.

The reconfigurable load platform was treated with a biocide substance having antiviral properties based on the active ingredient Silver Chloride.

The seat fabric was treated with a biocide substance with antiviral and antibacterial properties based on the active ingredient Alkyl (C12-C16) Dimethylbenzyl Ammonium Chloride.

The steering wheel upholstery was treated with biocide substances with antibacterial and antifungal properties based on the active ingredients Zinc Pyriothione and Thiabendazole.



The air cleaner of the climate control system was treated with a biocide substance having antibacterial and antiviral properties based on the active ingredient Dimethyltetradecyl[3-(trimethoxysilyl)propyl]ammonium chloride.

KNOWING THE INSTRUMENT PANEL

This section of the handbook provides all information that is useful for getting to know, interpreting, and using the instrument panel correctly.

INSTRUMENT PANEL FEATURES	52
DISPLAY	55
TRIP COMPUTER (Except the 1.0 FireFly Hybrid version)	65
TRIP COMPUTER (For the 1.0 FireFly Hybrid version)	66
EOBD SYSTEM	69
WARNING LIGHTS AND MESSAGES	70



INSTRUMENT PANEL FEATURES

The instrument background colour and type may vary according to the versions.

VERSIONS WITH MULTIFUNCTION DISPLAY

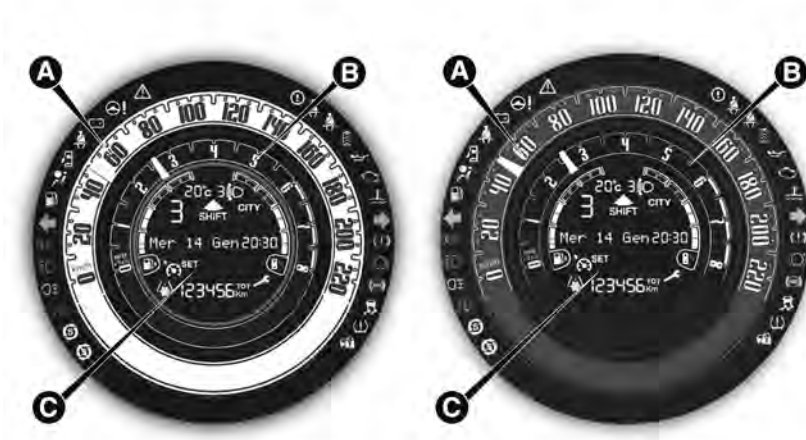

68

F0S0749

A. Speedometer B. Tachometer C. Multifunction display with digital fuel level gauge and digital coolant temperature gauge (for 1.2 8V 69 and 0.9 TwinAir versions) or auxiliary battery charge level indicator (for the 1.0 FireFly Hybrid version)

LOUNGE VERSIONS WITH COLOUR DISPLAY



69

F0S0750

A. Colour display B. "Eco Index" digital gauge C. Digital fuel level gauge D. Digital engine coolant temperature gauge E. Tachometer



SPEEDOMETER

Shows the car speed (speedometer).

TACHOMETER

This indicates the engine rpm.

DIGITAL FUEL LEVEL GAUGE

The digital gauge (A) fig. 70 (versions with multifunction display) or (A) fig. 71 (versions with colour display) shows the amount of fuel in the tank.



70

F0S0659

The warning light  switches on to indicate that approximately 5 litres of fuel are left in the tank.

Do not travel with the fuel tank almost empty: any gaps in fuel supply could damage the catalytic converter.



71

F0S0562

DIGITAL ENGINE COOLANT TEMPERATURE GAUGE

(for versions/markets, where provided)

The digital gauge (B) fig. 70 (versions with multifunction display) or (B) fig. 71 (versions with colour display) shows the temperature of the engine coolant and starts supplying indications when the fluid temperature exceeds approximately 50°C.

Versions with multifunction display

The first segment is always on to show the correct operation of the system.

NOTE For the 1.0 FireFly Hybrid version, the temperature indication is among the Trip Computer items.

Versions with colour display

The first reference, which is always on, is blue and indicates a low temperature of the engine coolant.

When the temperature increases the reference becomes white and other references come on as well. If the references become red, the temperature of the engine coolant is too high: in this case, see the "Warning lights and messages" chapter in this section.

The warning light  (for versions/markets, where provided) comes on when the coolant temperature increases excessively. In this case, stop the engine and contact a Fiat Dealership.

AUXILIARY LITHIUM BATTERY CHARGE LEVEL INDICATOR

(for the 1.0 FireFly Hybrid version - versions with multifunction display)

The digital indicator (A) fig. 72 shows the charge level of the auxiliary battery of the hybrid system. The eight segments light progressively from the bottom upwards as the battery charge state increases.



72

F080751

INSTRUMENT PANEL LIGHT ADJUSTMENT (brightness sensor)

(versions with colour display)

Versions with colour display are equipped with a brightness sensor (fitted inside the instrument panel) capable of detecting ambient light conditions and adjusting the brightness of the instrument panel accordingly. The behaviour of the instrument is as follows:

- "daytime" mode: the display can be set to 8 levels;
- "night time" mode: the display can be set to 8 levels.

The brightness of the radio and automatic dual zone climate control display is also adjusted.

For adjusting, see the "Display" paragraph in this chapter.

DISPLAY

NOTE With a low outside temperature (below 0°C), it may take longer than normal for information to appear on the display.

MULTIFUNCTION DISPLAY "STANDARD" SCREEN

Except the 1.0 FireFly Hybrid version

The standard screen fig. 73 shows the following information:

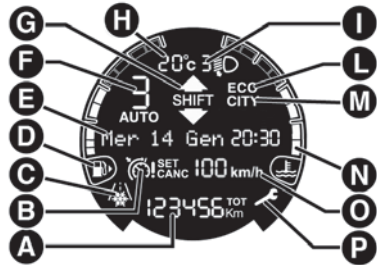

73

F0S0655

- A - Odometer (display of distance travelled in kilometres/miles)
- B - Cruise Control/Speed Limiter
- C - Warning of possible ice on the road
- D - Digital fuel level gauge
- E - Date and time
- F - Indication of engaged gear (Dualogic transmission versions only)
- G - Gear Shift Indicator

- H - Outside temperature gauge
- I - Headlight alignment position (with dipped beam headlights on only)
- L - ECO driving mode indication
- M - Dualdrive electric steering on
- N - Digital engine coolant temperature gauge
- O - Speed Limiter set speed
- P - Car service indicator

For the 1.0 FireFly Hybrid version

The standard screen fig. 74 shows the following information:

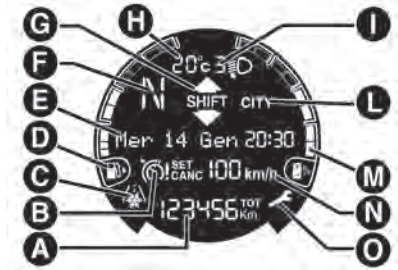

74

F0S0689

- A - Odometer (display of distance travelled in kilometres/miles)
- B - Cruise Control/Speed Limiter
- C - Warning of possible ice on the road
- D - Digital fuel level gauge
- E - Date and time
- F - Gear shift advice
- G - Gear Shift Indicator



- H - Outside temperature gauge
- I - Headlight alignment position (with dipped beam headlights on only)
- L - Dualdrive electric steering on
- M - Auxiliary battery charge level indicator
- N - Speed Limiter set speed
- O - Car maintenance indicator (service)

**COLOUR DISPLAY
“STANDARD” SCREEN**

Except the 1.0 FireFly Hybrid version

The standard screen fig. 75 shows the following information:

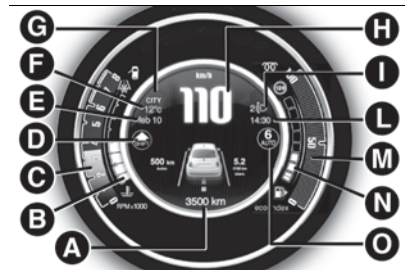

75

F0S0551

- A - Odometer (display of distance travelled in kilometres/miles)
- B - Digital engine coolant temperature indicator
- C - Digital rev counter (tachometer)
- D - Gear Shift Indicator
- E - Date

- F - Outside temperature gauge
- G - Dualdrive electric steering on
- H - Car speed indication
- I - Headlight alignment position (with dipped beam headlights on only)
- L - Time
- M - Eco Index
- N - Digital fuel level gauge
- O - Indication of engaged gear (Dualogic transmission versions only)

For the 1.0 FireFly Hybrid version



The standard screen fig. 76 shows the following information:



76

F0S0690

- A - Odometer (display of distance travelled in kilometres/miles)
- B - Digital engine coolant temperature indicator
- C - Digital rev counter (tachometer)
- D - Start&Stop system (with engine off) / GSI advice to shift to a higher gear

- () or lower gear () (while driving with the engine running)
- E - Date
- F - Outside temperature gauge
- G - Dualdrive electric steering on
- H - Car speed indication
- I - Headlight alignment position (with dipped beam headlights on only)
- L - Time
- M - Eco Index
- N - Digital fuel level gauge
- O - Suggested gear to be engaged with engine off (see "Advice to shift to neutral gear (N)" paragraph)

LOUNGE VERSION PAGES

(Versions with colour display)

Press the ECO (for versions/markets, where provided) or CITY button located on the dashboard to see the following pages fig. 77 and fig. 78.

Lounge ECO fig. 77



77

F0S0553

Lounge CITY fig. 78



78

F0S0426

DRIVING STYLE VIEW

(Versions with colour display—versions/markets, where provided)

ECO MODE

To activate the fig. 79 view, press the ECO button on the dashboard (see the "Dualdrive electric power steering" paragraph).

Press again the ECO button to deactivate the displaying or turn the ignition key to STOP.

ECO mode will be active whenever the engine is started.

ECO mode fig. 79



79

F0S0553

ECO INDEX

(Versions with colour display)

The eco Index allows the driver to monitor their driving style in order to achieve more efficient driving in terms of fuel economy and emissions reduction.

The assessment of the driving style is shown on the display through a digital graduated (A) fig. 80.



80

F0S0753

The scale ranges from a min. value of 0 up to max. value of 5 and indicates the eco-sustainability of the driving style (0 = low, 5 = high).

NOTES

The values measured are not directly connected to instant fuel consumption but are intended to suggest how the driver can alter their driving style in order to reduce consumption.

Different journeys may have different values even though the driver maintains the same driving style, since they are affected by factors such as traffic conditions, length of journey and engine cold starting.

An "eco" drive is a more "fluid" drive, even if traffic conditions often inhibit this. A more "aggressive" drive, on the other hand, implies frequent acceleration/deceleration with resulting



increased fuel consumption and harmful emissions.

AUXILIARY LITHIUM BATTERY CHARGE LEVEL INDICATOR

(For the 1.0 FireFly Hybrid version - versions with multifunction display)
The digital indicator (M) fig. 74 shows the charge level of the auxiliary battery of the hybrid system. The eight segments light progressively from the bottom upwards as the battery charge state increases.

GEAR SHIFT INDICATOR (Except the 1.0 FireFly Hybrid version)

The GSI (Gear Shift Indicator) system advises the driver to change gear through a special indication on the display.

Through the GSI, the driver is informed that shifting gear will allow a reduction in fuel consumption.

When the SHIFT (SHIFT UP) icon ▲ is shown on the display, the GSI is advising the driver to engage a higher gear, while the SHIFT (SHIFT DOWN) ▼ icon advises the driver to engage a lower gear.

The indication on the instrument panel remains until the driver shifts gear or the driving conditions return to a

situation where gear shifting is not required to improve consumption.

GEAR SHIFT INDICATOR (For the 1.0 FireFly Hybrid version)

(when driving on level road)
The GSI (Gear Shift Indicator) system advises the driver to change gear through a special indication on the display.

Through the GSI, the driver is informed that shifting gear will allow a reduction in fuel consumption.

When the ▲ icon is shown on the display, the GSI advises the driver to shift up, while the ▼ icon on the display advises the driver to shift down.

The indication on the instrument panel remains until the driver shifts gear or the driving conditions return to a situation where gear shifting is not required to improve consumption.
NOTE We recommend following the instructions given by the GSI system mainly on level roads; the instructions may be less accurate when driving on sloping roads or in the mountains because of the typical characteristics of these cases.

Advice to shift to neutral (N)

When the speed drops below 30 km/h and the conditions permit, the GSI advises shifting to neutral by displaying

the letter "N" and the indication ^{SHIFT}▼ ((A) fig. 81 for versions with multifunction display, (B) fig. 82 for versions with colour display). If the conditions permit, the heat engine turns off after shifting to neutral in order to reduce consumption ("EXTENDED S&S" function).



81

F0S0709



82

F0S0708

If you want to restart the engine by operating the clutch, the GSI will suggest the gear to be engaged most appropriate to the speed of the car, displaying it in position (A) fig. 83 (for

versions with multifunction display) or (B) fig. 84 (for versions with colour display).

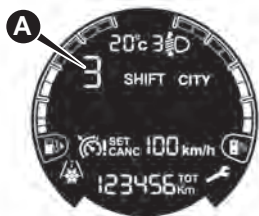

83

F0S0701



84

F0S0700

CONTROL BUTTONS

These are located by the side of the instrument panel fig. 85

+ / **-** : press and release to scroll the pages and the respective options up / down or to increase / decrease the displayed value.

MENU  : press briefly to access the menu and/or go to next screen or to confirm the required menu option. Hold down to go back to the standard screen.



85

F0S0383

NOTE When one of the front doors is opened, the display is activated showing the time and mileage for a few seconds.

SETUP MENU

The menu comprises a series of options which can be selected using buttons **+** and **-** fig. 85 to access the different selection and setting operations (Setup) indicated below.

The menu can be activated by briefly pressing the MENU button . Single presses on buttons **+** or **-** will scroll through the setup menu options. Operating modes are different according to the characteristics of the

option selected. Some options have a submenu.

The menu comprises the following functions:

- MENU
- DIMMER
- SPEED BEEP
- TRIP B ACTIVATION / DATA
- SET TIME
- SET DATE
- AUTOCLOSE
- UNITS
- LANGUAGE
- ALERT VOLUME
- BUTTON VOLUME
- SEAT BELT BUZZER
- SERVICE
- AIRBAG / PASSENGER AIRBAG
- DAYTIME RUNNING LIGHTS
- RESET TYRES
- SEE RADIO (for markets/versions, where provided)
- SEE PHONE (for versions/markets, where provided)
- SEE NAVIGATION (for versions/markets, where provided)
- EXIT MENU

Selecting an item from the main menu without a submenu:

press the MENU  button briefly to select the main menu setting you wish to change;



- press the **+** or **-** buttons (with single presses) to select the new setting;
- briefly press the MENU button **↵** to store the new setting and to go back to the same main menu option selected previously.

Selecting an option from the main menu with a submenu:

- briefly press the MENU button **↵** to display the first submenu option;
- press the **+** or **-** buttons (with single presses) to scroll through all the submenu items;
- briefly press the MENU button **↵** to select the displayed submenu option and to open the relevant setup menu;
- press the **+** or **-** buttons (with single presses) to select the new setting for this submenu option;
- a short press on MENU button **↵** will store the setting and then return to the same submenu option that was first selected.

Note With **Uconnect™** system (for versions/markets where provided), some Menu items are shown and managed on the display of the latter and not on the instrument panel display (refer to the **Uconnect™** supplement).

Menu

This option allows you to access the Setup Menu.

Press the **+** or **-** button to select the various Menu options.

Hold down the **↵** MENU button to return to the standard screen.

Dimmer (Car interior lighting adjustment)

On some versions, the instrument panel is provided with a light sensor capable of detecting environmental light conditions and adjusting the brightness of the instruments accordingly.

The brightness of the instrument panel may therefore change while driving following an event causing a switch from “day” to “night” conditions (or vice versa) in the passenger compartment (e.g. in a tunnel, on avenues in shadows, under flyovers, etc.).

The lighting can be adjusted in night mode only with dipped beam headlights on. If the headlights are not on, it can be adjusted in day mode.

This function is available, with the dipped headlights on and in night-time conditions, to adjust the brightness of the instrument panel, control buttons, sound system display and automatic climate control display.

On some versions, during the daytime and with dipped headlights on, the instrument panel, control buttons, sound system and automatic climate control displays are set to maximum brightness.

Proceed as follows to adjust the light intensity:

- press the MENU button **↵** briefly to make the display flash the previously stored level;
- press the **+** or **-** button to adjust the brightness level;
- press the MENU button **↵** briefly to return to the menu screen or hold the button down to return to the standard screen without storing.

Speed beep (Speed limit)

This function is used to set the car speed limit (km/h or mph); the driver is immediately alerted when this limit is exceeded (see section “Warning lights and messages”).

To set the desired speed limit, proceed as follows:



- briefly press the MENU button **↵**: the display will show the words (Speed Beep);
- press the **+** or **-** button to select speed limit activation (“On”) or deactivation (“Off”);
- if the function is enabled (On), press the **+** or **-** button to select the required speed limit and press the MENU button **↵** to confirm.

Note The speed may be set anywhere between 30 and 200 km/h or 20 and 125 mph, depending on the previously chosen unit (see the “Setting the unit of measurement (Unit)” paragraph).

The setting will increase/decrease by 5 units each time button + / - is pressed. Hold down the + / - button to automatically increase/decrease the setting rapidly. Complete the adjustment with single presses of the button when you approach the desired value.

Press the MENU button  briefly to return to the menu screen or hold the button down to return to the standard screen without storing.

To cancel the setting, proceed as follows:

- press the MENU button  briefly: ("On") will flash on the display;
- press - button, "Off" will flash on the display;
- press the MENU button  briefly to return to the menu screen or hold the button down to return to the standard screen without storing.

Activation/Trip B data (Trip B enabling)

This function may be used to activate ("On") or deactivate ("Off") the Trip B (partial trip) display.

For further information see the "Trip computer" paragraph in this chapter. Proceed as follows to switch the function on/off:





- press the  MENU button briefly, the display will flash "On" or "Off" depending on the previous setting;

- press + or - button to select;
- press the MENU button  briefly to return to the menu screen or hold the button down to return to the standard screen without storing.



Set Time (Setting the clock)

Using this function, it is possible to set the clock through two submenus: "Time" and "Format".

To adjust, proceed as follows:

- briefly press the MENU  button: the display will show the two submenus "Time" and "Format";
- press the + or - button to move between the two submenus;
- once you have selected a submenu, press the MENU  button briefly;
- when you select the "Time" submenu, pressing the MENU  button briefly the display shows the "hours";
- press the + or - button to adjust;
- briefly pressing the MENU  button the "minutes" are displayed;
- press the + or - button to adjust.



Note The setting will increase or decrease by one unit each time the + or - button is pressed. Hold down the button to increase/decrease the setting rapidly and automatically. Complete the adjustment with single presses of the button when you approach the desired value.

- When you select the "Format" submenu, pressing the MENU  button briefly the mode is displayed;
- press + or - to select "24h" or "12h". When you have made the adjustment, press the MENU button  briefly to return to the submenu screen or hold the button down to return to the main menu screen without storing.
- hold the MENU button  or SAVE for colour displays down again to return to the standard screen or to the main menu according to where you are in the menu.

Set date (Setting the date)

This function may be used to update the date (year/month/day).

To adjust, proceed as follows:

- briefly press the MENU  button: "year" will be displayed;
- press the + or - button to adjust;
- briefly press the MENU  button: "month" is displayed;
- press the + or - button to adjust;
- briefly press the MENU  button: "day" is displayed;
- press the + or - button to adjust;

Note The setting will increase or decrease by one unit each time the + or - button is pressed. Hold down the button to increase/decrease the setting rapidly and automatically. Complete the



adjustment with single presses of the button when you approach the desired value.

press the **↵** MENU button, or SAVE for colour displays, briefly to return to the menu screen or hold the button down to return to the standard screen without storing.

Autoclose (Automatic central locking with car moving)

(for versions/markets, where provided)

When activated (On), this function locks the doors automatically when the vehicle speed exceeds 20 km/h.

Proceed as follows to activate or deactivate this function:

- press the MENU button **↵** briefly to display a submenu;
- press the **↵** MENU button briefly, the display will flash "On" or "Off" depending on the previous setting;
- press the **+** or **-** button to select;
- press the **↵** MENU button briefly to return to the submenu screen or hold the button down to return to the main menu screen without saving;
- hold the MENU button **↵** down again to return to the standard screen or to the main menu according to where you are in the menu.

Units (Setting the unit of measurement)

This function allows the measurement unit to be set via two submenus: "Distance" and "Fuel Consumption".

To set the desired unit of measurement, proceed as follows:

- briefly press the MENU button **↵**: the display will show the two submenus;
- press the **+** or **-** button to move between the two submenus;
- once you have selected a submenu, press the **↵** MENU button briefly;
- you enter the "Distance" submenu: pressing the MENU button briefly, the display shows "km" or "mi" depending on the previous setting;
- press the **+** or **-** button to select;
- when you select "Fuel Consumption", briefly pressing the MENU button **↵** makes km/l, l/100km or mpg appear on the display depending on the previous setting;

If the set distance unit of measurement is "km", the fuel consumption unit will be displayed in km/l or l/100 km.

If the set distance unit is "mi" the fuel consumption unit will be displayed in "mpg".

- Press the **+** or **-** button to select. When you have made the adjustment, press the MENU button **↵** briefly to return to the submenu screen or hold

the button down to return to the main menu screen without storing.

- Hold the MENU button **↵** down again to return to the standard screen or to the main menu according to where you are in the menu.

Language (Language selection)

Messages on the display can be shown in the following languages: Italian, English, German, Portuguese, Spanish, French, Dutch, Polish, Turkish and Russian.

To set the desired language, proceed as follows:

- briefly press the MENU button **↵**: the previously set "language" will flash on the display;
- press the **+** or **-** button to select;
- press the MENU button **↵** briefly to return to the menu screen or hold the button down to return to the standard screen without storing.

Buzzer volume (Adjusting the failure/warning acoustic signal volume)

This function allows the volume of the buzzer which accompanies the display of failures / warnings to be adjusted to 8 levels.

To set the desired volume, proceed as follows:



- briefly press the MENU button **↵**: the previously set volume level will flash on the display;

- press the + or – button to adjust;
- press the MENU button  briefly to return to the menu screen or hold the button down to return to the standard screen without storing.

Button volume (Adjusting the button volume)

This function may be used to adjust (to 8 levels) the volume of the acoustic signal made when the  MENU, + and – buttons are pressed.

To set the desired volume, proceed as follows:

- briefly press the MENU button : the previously set volume level will flash on the display;
- press the + or – button to adjust;
- press the MENU button  briefly to return to the menu screen or hold the button down to return to the standard screen without storing.

Seat belt buzzer (Reactivation of buzzer for SBR signal)

This function can be only displayed after Fiat Dealership has deactivated the SBR system (see paragraph “SBR system” in the “Safety devices” chapter).



To reactivate this function, proceed as follows:

- press the  MENU button briefly and the display will flash "Off". Press the button + or – to display "On";

- press the  MENU button briefly to return to the submenu screen or hold the button down to return to the main menu screen without saving.

Service (scheduled servicing)

This function allows you to display the information about km/mileage intervals or, for versions/markets, where provided, time intervals for car maintenance. To consult the information, proceed as follows:

- press the MENU  button: the display shows when servicing is due in km/mi or days (where provided) according to the previous setting (see paragraph "Units of measurement");
- press the MENU  button to return to the menu screen; press the button again to return to the standard screen.



WARNING The “Service Schedule” includes car maintenance at fixed intervals (refer to the "Maintenance and care" chapter).

This is displayed automatically, with ignition key at MAR-ON, 2000 km (or equivalent value in miles) before servicing or, where provided, 30 days before servicing. It is also displayed

each time the key is turned to MAR-ON or, for versions/markets, where provided, every 200 km (or equivalent value in miles). Below this threshold servicing indications are more frequent. The display will be in km or miles according to the unit of measurement set. When the following scheduled servicing is approaching, the word “Service” will appear on the display, followed by the number of kilometres/miles or days (where provided) left, when the key is turned to MAR. Go to a Fiat Dealership, where the "Service Schedule" operations will be performed and the message will be reset.

Airbag/Passenger airbag (Activation/deactivation of passenger side front airbag and side bag for pelvis, chest and shoulder protection)– versions/markets, where provided

This function is used to activate/deactivate the front passenger side airbag. Proceed as follows:

- press the MENU  button and, after the display shows the message "Bag pass: Off" (to deactivate) or the message (Passenger Bag: On" (to activate) through the pressing of the + and – buttons, press the MENU  button again;



□ a confirmation request message will appear on the display;

□ press the **+** or **-** buttons to select "Yes" (to confirm enable/disable) or "No" (to abort);

□ press the MENU button **↵** briefly, a message confirming the selection will be displayed and you will return to the menu screen or hold the button down to return to the standard screen without storing.

Daytime running lights (DRL)

(for versions/markets, where provided)

With this function is possible to turn the daytime running lights on and off.

Proceed as follows to activate or deactivate this function:

□ press the MENU button **↵** briefly to display a submenu;

□ press the **↵** MENU button briefly, the display will flash "On" or "Off" depending on the previous setting;

□ press **+** or **-** button to select;

□ press the **↵** MENU button briefly to return to the submenu screen or hold the button down to return to the main menu screen without saving;

□ hold the MENU button **↵** down again to return to the standard screen or to the main menu according to where you are in the menu.

Reset tyres (iTPMS reset)

(For versions/markets, where provided)

With this function it is possible to reset the iTPMS (see paragraph "iTPMS").

To carry out the Reset procedure proceed as follows:

□ briefly press the MENU **↵** button: the display will show Reset;

□ press the **+** or **-** button to select ("Yes" or "No");

□ briefly press the MENU **↵** button: the display will show "Confirm";

□ press the **+** or **-** button to select ("Yes" to reset or "No" to exit the video page). A message confirming the successful Reset will be displayed;

□ hold the MENU button **↵** down again to return to the standard screen or to the main menu according to where you are in the menu.

Radio repetition (audio information repetition)

(for versions/markets, where provided)

This Menu item allows some information displayed on the **Uconnect™** system to be repeated on the instrument panel display.

To show the **Uconnect™** information on the display ("On"), or clear it ("Off"), proceed as follows:

□ press the **↵** MENU button briefly, the display will flash "On" or "Off" depending on the previous setting;

□ press the **+** or **-** button to select;

□ press the MENU button **↵** briefly to return to the menu screen or hold the button down to return to the standard screen without storing.

See phone

(for versions/markets, where provided)

This Menu item allows some information displayed on the **Uconnect™** system to be repeated on the instrument panel display.

To show the **Uconnect™** information on the display ("On"), or clear it ("Off"), proceed as follows:

□ press the **↵** MENU button briefly, the display will flash "On" or "Off" depending on the previous setting;

□ press the **+** or **-** button to select;

□ press the MENU button **↵** briefly to return to the menu screen or hold the button down to return to the standard screen without storing.

See navigation

(for versions/markets, where provided)

This Menu item allows some information displayed on the **Uconnect™** system to be repeated on the instrument panel display.

To show the **Uconnect™** information on the display ("On"), or clear it ("Off"), proceed as follows:

□ press the **↵** MENU button briefly, the display will flash "On" or "Off" depending on the previous setting;

- press the + or – button to select;
- press the MENU button  briefly to return to the menu screen or hold the button down to return to the standard screen without storing.

Exit Menu

This is the last function that closes the cycle of settings listed in the menu screen.

Pressing the MENU button  briefly will return the display to the standard screen without storing.

Press the – button to go back to the first menu option ("Speed Beep").

HEADLIGHT ALIGNMENT

With the ignition key at MAR and dipped beam headlights on, press the – button to adjust the headlights upwards and the button to adjust the headlights downwards.

TRIP COMPUTER (Except the 1.0 FireFly Hybrid version)

GENERAL INFORMATION

The Trip computer is used to display information on car operation when the ignition key is turned to MAR.

This function allows you to define two separate trips, called "Trip A" and "Trip B", for monitoring the car's "complete mission" (journey) in a reciprocally independent manner and, for versions/markets where provided, "Instant info" and "Best average consumption".

Both Trip A and Trip B can be zeroed (reset - start of a new journey).

"Trip A" can be used to display the values relating to:

- Range (for versions/markets, where provided)
- Travel Distance A
- Average Fuel Consumption A
- Current consumption (for versions/markets, where provided)
- Average Speed A
- Travel time (driving time). "Trip B" shall be used to display the figures relating to:
- Travel Distance B

- Average Fuel Consumption B
- Average Speed B
- Travel Time B (driving time)

NOTE "Trip B" may be excluded.

"Range" and "Current Consumption" values cannot be reset.

"Best average consumption": in ECO mode, displays a screen summarising the best average consumption (where provided). The icon  indicates the best performance. This information can be reset by resetting Trip A.

TRIP BUTTON

The TRIP button is located on the right-hand stalk fig. 86. With the ignition key turned to MAR, this button allows you to view the previously described values and also zero them to begin a new mission:

- *brief press* to access the various parameter displays;
- *long press* to reset and then start a new mission.

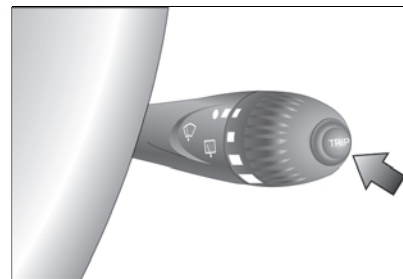

86

F0S0080



New mission

This begins after a reset:

- "manual" resetting by the user, by pressing the relevant button;
- "automatic" resetting, when the "trip distance" reaches 9999.9 km or when the "travel time" reaches 99:59 (99 hours and 59 minutes);
- after disconnection/reconnection of the battery.

WARNING The reset operation when "Trip A" or "Trip B" details are being displayed resets the information associated with the function displayed.

Start of journey procedure

With the ignition key in the MAR-ON position, reset by pressing the TRIP button and keeping it pressed for more than 2 seconds.

Exit Trip

You can automatically exit the TRIP function once all the values have been displayed or by holding the MENU button  down for more than 1 second.

TRIP COMPUTER (For the 1.0 FireFly Hybrid version)

GENERAL INFORMATION

The Trip computer is used to display information on car operation when the ignition key is turned to MAR. It is composed of two separate trips, called "Trip A" and "Trip B", which can monitor the "entire mission" (journey) independently from each other.

The following screens are available:

- Instant info (versions with colour display):
 - Range
 - Current Consumption
- Trip A:
 - Engine coolant temperature (versions with multifunction display)
 - Range (versions with multifunction display)
 - Average Fuel Consumption A
 - Current Consumption (versions with multifunction display)
 - Average Speed A
 - Travel Distance A
 - Travel Time A (driving time)
 - Energy Recovery A
 - Energy consumption A (versions with colour display)

- Auxiliary battery A (versions with colour display)

□ Trip B:

- Average Fuel Consumption B
 - Average Speed B
 - Travel Distance B
 - Travel Time B (driving time)
 - Energy Recovery B
 - Energy consumption B (versions with colour display)
 - Auxiliary battery B (versions with colour display)
- Best Average Consumption (versions with colour display) displays a screen summarising the best average consumption. The icon  indicates the best performance. This information can be reset by resetting Trip A.
- TPMS (for versions/markets, where provided)
- Nav Repeat (for markets/versions, where provided)
- NOTE "Range" and "Current Consumption" values cannot be reset. NOTE Both Trip A and Trip B can be zeroed (reset - start of a new journey). NOTE "Trip B" can be activated or deactivated from the setup menu on the display with the "Trip B Activation/Data" function. For further information see the "Display" paragraph in this chapter.

NOTE The screen order may vary between the multifunction and colour displays.

Engine coolant temperature

(versions with multifunction display)

Shows the engine coolant temperature with an 8-level indicator on 4 circles fig. 87. The circles (A) are progressively coloured partially or fully from left to right as the temperature increases.



87

F0S0691

TRIP BUTTON

The TRIP button is located on the right-hand stalk fig. 88. With the ignition key turned to MAR, this button allows you to view the previously described values and also zero them to begin a new mission:

- *brief press* to access the various parameter displays;
- *long press* to reset and then start a new mission.

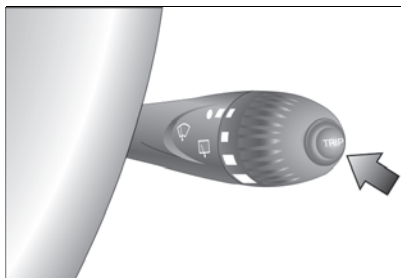

88

F0S0090

New mission

This begins after a reset:

- "manual" resetting by the user, by pressing the relevant button;
- "automatic" resetting, when the "trip distance" reaches 9999.9 km or when the "travel time" reaches 99:59 (99 hours and 59 minutes);
- after disconnecting/reconnecting the conventional battery.

WARNING The reset operation when "Trip A" or "Trip B" details are being displayed resets the information associated with the function displayed.

Start of journey procedure

With the ignition key in the MAR-ON position, reset by pressing the TRIP button and keeping it pressed for more than 2 seconds.

Exit Trip

You can automatically exit the TRIP function once all the values have been displayed or by holding the MENU button  down for more than 1 second.

HYBRID SYSTEM SCREENS



Energy Recovery (Trip A/Trip B)

The screen in fig. 89 (for versions with colour display) shows the cumulative value (A) of the energy recovered during car deceleration (with a gear engaged), used to charge the auxiliary lithium battery.

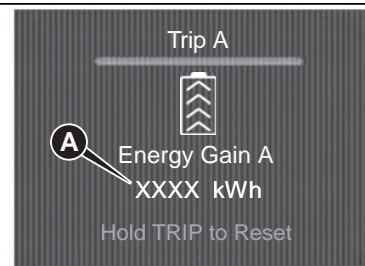

89

F0S0684

For versions with multifunction display, the  indicator light turns on during the energy recovery phase. The amount



of energy recovered is shown in the "Energy Recovery" item on the Trip Computer.

Energy Flows

(versions with colour display)

The central area (A) of the screen fig. 90 indicates the hybrid system usage mode in real time by showing the energy flow to and from the auxiliary battery and electric motor in different colours. The different types of display are described in detail below:

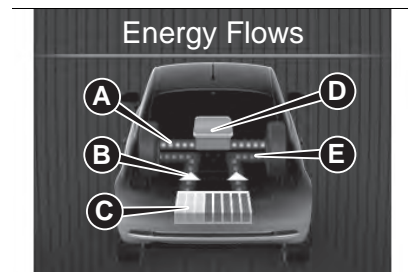

90

F0S0679

□ Driving with heat engine only:

white flows on a yellow background (A) moving from the heat engine (D) to the wheels indicate that the drive is provided by the heat engine alone.

□ **Auxiliary battery charging:** white flows on a green background (E) indicate that energy passes from the wheels to the auxiliary battery (C). The

direction of the arrows (B) indicate the flow direction.

NOTE If the conventional battery is flat, there is no energy recovery to the auxiliary battery, and so the screen does not display the relative recharging flows.

□ Electric motor assisting the heat engine:

white flows on a blue background (E) and the direction of the arrows (B) from the auxiliary battery (C) to the heat engine indicate combined drive from the heat engine and electric motor. The contribution of the electrical motor is shown by the white flows on a yellow background (A) from the auxiliary battery (C).

Energy Consumption

(versions with colour display)

The auxiliary battery charge level is indicated by set of 8 green bars (A) fig. 91. The more coloured bars there are, the greater the battery charge state.

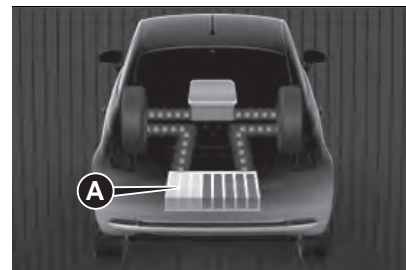

91

F0S0698

When the battery charge state is below 10%, the last bar remains on but is yellow fig. 92. Some hybrid system functions may be disabled in these conditions.

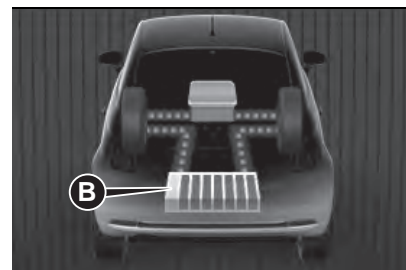

92

F0S0702

Auxiliary battery

(versions with colour display)

The diagram fig. 93 gives a real-time view of the power provided by the auxiliary battery during acceleration (light blue bars) and the power

accumulated during deceleration (green bars, the brightness of which is proportional to how flat the battery is and may vary with the battery temperature condition).

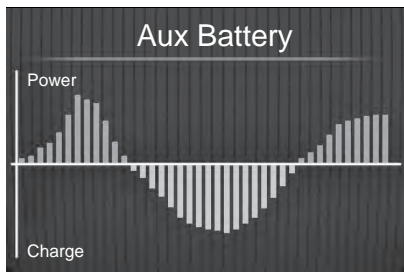

93

F0S0680

ITPMS SCREEN

(for versions/markets, where provided.
For versions with colour display)
The screen shows the tyre pressure status. The screen of fig. 94 appears of the pressure is correct.



94

F0S0496

For how the ITPMS operates, refer to the "Driving assistance systems" paragraph in the "Safety" chapter.

NAV REPEAT

(for versions/markets, where provided.
For versions with colour display)
When navigation is enabled through the **Uconnect™** system, the road directions are repeated on the display.
NOTE Nav repeat can be activated from the setup menu on the display with the "See navigation" function. For further information see the "Display" paragraph in this chapter.

EOBD SYSTEM

The EOBD system (European On Board Diagnosis) carries out a continuous diagnosis of the components of the car related to emissions.

It also turns on the  warning light on the instrument panel to warn when these components are no longer in peak condition (see "Warning lights and messages" paragraph in this chapter).

The goal of the system is to:

- monitor system efficiency;
- indicate an increase in emissions due to vehicle malfunction;
- indicate the need to replace damaged components.

The car also has a connector, which can interface with appropriate tools, that makes it possible to read the error codes stored in the electronic control units together with a series of specific parameters for engine operation and diagnosis. This check can also be carried out by the traffic police.

WARNING After eliminating the failure, to check the system completely, Fiat Dealerships run a bench test and, if necessary, road tests which may also call for a long journey.



WARNING LIGHTS AND MESSAGES





IMPORTANT NOTES

WARNING Warning lights are accompanied by a specific message and/or sound when implemented on the instrument panel. These indications are indicative and precautionary and as such must not be considered as exhaustive and/or alternative to the information contained in the Owner Handbook, which you are advised to read carefully in all cases. In the event of a failure indication, always refer to the contents of this chapter.







WARNING The failure indicators appearing on the display are divided into two categories: very serious and less serious faults. Serious faults are indicated by a repeated and prolonged warning "cycle". Less serious faults are indicated by a warning "cycle" with a shorter duration. The display cycle of both categories can be interrupted by pressing the MENU button . The instrument panel warning light will stay on until the cause of the malfunction is eliminated.





WARNING LIGHTS ON INSTRUMENT PANEL

Red warning lights



Warning light	What it means
 <p>red</p>	<p>SEAT BELTS REMINDER</p> <p>The warning light switches on constantly with the car stationary and the driver's side or passenger side seat belt (when the passenger is present) not fastened.</p> <p>The warning light will flash and a buzzer will sound if the car is in motion and the front seat belts are not correctly fastened.</p> <p>For permanent deactivation of the acoustic signal (buzzer) of the SBR (Seat Belt Reminder) system contact a Fiat Dealership. The system can be reactivated at any time using the Setup Menu.</p>
 <p>red</p>  <p>yellow</p>  <p>yellow (Versions with multifunction display)</p>  <p>yellow (Versions with colour display)</p>	<p>EBD FAILURE</p> <p>The simultaneous switching on of the warning lights with the engine on indicates either an anomaly of the EBD system or that the system is not available. In this case, the rear wheels may suddenly lock and the car may swerve when braking sharply.</p> <p>Drive very carefully to a Fiat Dealership to have the system inspected.</p>



Warning light	What it means
 <p data-bbox="352 314 384 331">red</p>	<p data-bbox="576 113 1198 129">CONVENTIONAL LEAD BATTERY NOT SUFFICIENTLY CHARGED</p> <p data-bbox="576 138 1442 208">The warning light switches on when the ignition key is turned to MAR, but it should switch off as soon as the engine has started (with the engine idling a brief delay before switching off is acceptable).</p> <p data-bbox="576 213 1418 230">If the warning light or symbol on the display stay on, contact a Fiat Dealership immediately.</p> <hr/> <p data-bbox="576 262 831 278">HYBRID SYSTEM FAILURE</p> <p data-bbox="576 287 887 304">(for the 1.0 FireFly Hybrid version)</p> <p data-bbox="576 313 1501 413">The warning light or symbol also appears on the display in the event of a hybrid system failure. For this warning, the warning light or symbol could appear together with the  symbol/warning light (versions with colour display only) and/or  symbol. The charge state of the auxiliary battery will not be displayed in this case.</p> <p data-bbox="576 422 1007 439">Contact a Fiat Dealership as soon as possible.</p>
 <p data-bbox="352 570 384 586">red</p>	<p data-bbox="576 469 743 486">AIRBAG FAILURE</p> <p data-bbox="576 495 1501 538">The warning light switches on when the ignition key is turned to MAR, but it should switch off after a few seconds.</p> <p data-bbox="576 547 1270 564">The warning light stays on constantly if there is a fault in the airbag system.</p> <p data-bbox="576 573 647 590"> 47) 48)</p>
 <p data-bbox="352 818 384 835">red</p>	<p data-bbox="576 620 1003 637">LOW BRAKE FLUID/HANDBRAKE ENGAGED</p> <p data-bbox="576 646 1501 689">The warning light switches on when the ignition key is turned to MAR, but it should switch off after a few seconds.</p> <hr/> <p data-bbox="576 721 788 738">Low brake fluid level</p> <p data-bbox="576 747 1490 790">The warning light turns on when the level of the brake fluid in the reservoir falls below the minimum level, possibly due to a leak in the circuit.</p> <p data-bbox="576 799 624 816"> 49)</p> <hr/> <p data-bbox="576 844 783 861">Handbrake engaged</p> <p data-bbox="576 870 1163 887">The warning light switches on when the handbrake is engaged.</p> <p data-bbox="576 896 1286 912">On certain versions, if the car is moving the acoustic warning will also sound.</p> <p data-bbox="576 921 1474 938">IMPORTANT If the warning light turns on while driving, check that the handbrake is not engaged.</p>

Warning light	What it means
 <p data-bbox="247 235 279 257">red</p>	<p data-bbox="470 112 758 134">LOW ENGINE OIL PRESSURE</p> <p data-bbox="470 140 1364 184">When the ignition key is turned to MAR, the warning light (for versions/markets, where provided) switches on, but it should switch off as soon as the engine is started.</p> <p data-bbox="470 190 1380 263">NOTE For versions/markets, where provided, the indicator may be amber. The warning light or the symbol come on constantly (for versions/markets, where provided) when the system detects that the engine oil pressure is low.</p> <p data-bbox="470 263 518 285"> 50)</p>
 <p data-bbox="247 537 279 560">red</p>	<p data-bbox="470 313 917 336">ENGINE COOLANT TEMPERATURE TOO HIGH</p> <p data-bbox="470 341 1364 408">The warning light switches on when the ignition key is turned to MAR, but it should switch off after a few seconds. The warning light or symbol on the display comes on when the engine has overheated.</p> <p data-bbox="470 414 1396 543">☐ In normal driving conditions: stop the car, switch off the engine and check that the fluid level in the reservoir is not below the MIN mark. In this case, wait for the engine to cool down, then slowly and carefully open the cap, top up with coolant and check that the level is between the MIN and MAX marks on the reservoir itself. Also check visually for any fluid leaks. If, when restarting, the warning light switches on again, contact a Fiat Dealership;</p> <p data-bbox="470 548 1380 644">☐ If the car is used under demanding conditions (e.g. towing trailers uphill or fully loaded): slow down and, if the warning light stays on, stop the car. Stop for two or three minutes with the engine running and slightly accelerated to facilitate better coolant circulation, then turn the engine off. Check that the coolant level is correct as described above.</p> <p data-bbox="470 649 1316 694">IMPORTANT Over demanding routes, it is advisable to keep the engine running and slightly accelerated for a few minutes before turning it off.</p>
 <p data-bbox="247 817 279 840">red</p>	<p data-bbox="470 722 845 744">"DUALOGIC" TRANSMISSION FAILURE</p> <p data-bbox="470 750 1380 795">When the ignition key is turned to MAR, the warning light switches on but should switch off after a few seconds.</p> <p data-bbox="470 800 1316 823">The warning light flashes, along with an acoustic warning, to indicate a transmission failure.</p> <p data-bbox="470 823 518 845"> 33)</p>







Warning light	What it means
 <p data-bbox="352 340 384 357">red</p>	<p data-bbox="576 113 1086 129">“DUALDRIVE” ELECTRIC POWER STEERING FAILURE</p> <p data-bbox="576 138 1485 210">The warning light switches on when the ignition key is turned to MAR, but it should switch off after a few seconds. If the warning light remains on, you may have no power steering and the effort required to operate the steering wheel could be increased; steering is, however, possible.</p> <p data-bbox="576 219 927 236">In this case, contact a Fiat Dealership.</p> <p data-bbox="576 245 1501 311">If the warning light comes on while driving you may not have steering assistance. Although it will still be possible to steer the vehicle, the effort needed to operate the steering wheel could be increased: contact a Fiat Dealership as soon as possible.</p> <p data-bbox="576 320 1501 412">WARNING In some circumstances, factors independent of the electric power steering could cause the warning light on the instrument panel to switch on. In this case, stop the car immediately (should it be in motion), stop the engine for about 20 seconds and then restart the engine. If the warning light stays on, contact a Fiat Dealership.</p> <p data-bbox="576 421 1501 487">IMPORTANT NOTE The steering must be initialised after disconnecting the conventional battery. The warning light turns on to indicate this. To carry out this procedure, simply turn the steering wheel all the way from one end to the other or drive in a straight line for about a hundred metres.</p>
 <p data-bbox="352 617 384 633">red</p>	<p data-bbox="576 527 1230 544">OPEN DOORS / BONNET / BOOT (versions with multifunctional display)</p> <p data-bbox="576 553 1501 619">The warning light appears on the display when one or more doors, the tailgate or the bonnet (for versions/markets, where provided) are not properly closed. An acoustic warning is also emitted with the doors open and the car in motion.</p>



WARNING

47) If, when the ignition key is turned to MAR, the warning light  does not switch on or stays on while driving, a failure may have occurred in the restraint systems. In this case the airbags or pretensioners may not be deployed in an impact or, in a lower number of cases, they may be deployed accidentally. Before continuing, contact a Fiat Dealership immediately to have the system checked.

48) A failure of the warning light  is indicated by the  symbol appearing on the display or by the  warning light blinking, depending on the version. In this case, the  warning light may not indicate a possible problem with the airbag restraint system. Before continuing, contact a Fiat Dealership immediately to have the system checked.

49) If the  warning light comes on while driving, stop the car immediately and contact a Fiat Dealership.

50) If the  warning light comes on while driving, stop the engine immediately and contact a Fiat Dealership.











IMPORTANT

33) *If the transmission is faulty, contact a Fiat Dealership as soon as possible to have the system checked.*











Amber warning lights

Warning light	What it means
 <p>yellow</p>	<p>BRAKE PAD WEAR The warning light switches on if the front or rear (for versions/markets, where provided) brake pads are worn. In this case have them replaced as soon as possible.</p>
 <p>yellow (Versions with multifunction display)</p>  <p>yellow (Versions with colour display)</p>	<p>ESC SYSTEM The warning light comes on when the ignition key is turned to MAR, but should go off after a few seconds.</p> <hr/> <p>ESC system activation Flashing of the warning light while driving indicates the intervention of the ESC system.</p> <hr/> <p>ESC system failure If the warning light does not go off or stays on together with the LED on the ASR OFF button while driving. Contact a Fiat Dealership.</p> <hr/> <p>Hill Holder failure The warning light will turn on to indicate a Hill Holder system failure. In this case, contact a Fiat Dealership as soon as possible.</p>

Warning light	What it means
 <p>yellow</p>	<p>INJECTION / EOBD SYSTEM FAILURE Under normal conditions, the warning light comes on when the ignition key is turned to MAR, but should go off as soon as the engine is started. If the warning light remains on or comes on while driving, the injection system is not working properly; in particular, if the warning light comes on constantly, this indicates a malfunction in the supply/ignition system that could cause excessive exhaust emissions, a possible loss of performance, poor driveability and high fuel consumption. Under these conditions, the vehicle can continue travelling at moderate speed without demanding excessive effort from the engine. Prolonged use of the car with the warning light on may cause damage. Contact a Fiat Dealership as soon as possible. If the warning light is flashing, this indicates that the catalytic converter may be damaged. If the light flashes, come off the accelerator pedal to reduce engine revs until the warning light stops flashing; continue the journey at moderate speed, trying to avoid driving conditions that may cause further flashing, and get to a Fiat Dealership as soon as possible.</p> <p> 51)</p>
 <p>yellow</p>	<p>FIAT CODE SYSTEM FAILURE With the ignition key in the MAR position, the warning light or the symbol on the display come on constantly to indicate a possible Fiat Code system failure. If the warning light or symbol blinks on the display with engine running, it means that the vehicle is not protected by the engine immobiliser device. In this case, contact a Fiat Dealership as soon as possible.</p>
 <p>yellow</p>	<p>FUEL RESERVE - LIMITED RANGE The warning light switches on when the ignition key is turned to MAR, but it should switch off after a few seconds. The warning light or the symbol switches on in the display when about 5 litres of fuel are left in the tank. The triangle on the right side of the symbol indicates the side of the car with the fuel filler. IMPORTANT If the warning light flashes or the symbol is constantly on, depending on the versions, there is a fault in the system. If this is the case, go to a Fiat Dealership to have the system checked.</p>
 <p>yellow</p>	<p>REAR FOG LIGHT The warning light switches on when the rear fog light is turned on.</p>







Warning light	What it means
 <p>yellow</p>	<p>ABS FAILURE The warning light switches on when the ignition key is turned to MAR, but it should switch off after a few seconds. The warning light will light up when the system is either not working or not available. In this case the braking system maintains its efficiency unaltered but without the advantage of the ABS system. Drive carefully and contact a Fiat Dealership as soon as possible.</p>
 <p>yellow</p>	<p>GENERAL FAILURE INDICATION The warning light switches on in the following circumstances. In these cases contact a Fiat Dealership to have the problem fixed as soon as possible.</p> <hr/> <p>Engine oil pressure sensor failure The warning light switches on when an engine oil pressure sensor anomaly is detected.</p> <hr/> <p>Fuel cut-off system intervention/failure The warning light comes on when the fuel cut-off system intervenes.</p> <hr/> <p>Exterior lights failure The warning light switches on when an external light failure is detected.</p> <hr/> <p>Parking sensor failure The warning light turns on when a fault is detected in the parking sensors.</p> <hr/> <p>Start&Stop system failure (versions with multifunction display) A failure of the system is indicated by the warning light switching on.</p> <hr/> <p>Airbag warning light fault (for versions/markets where provided)  62) The warning light blinks when a fault is detected in the warning light </p> <hr/> <p>Rain sensor failure (for versions/markets where provided) The warning light (or symbol for versions with multifunction reconfigurable display) comes on when a fault is detected in the rain sensor.</p> <hr/> <p>Dusk sensor fault (for versions/markets where provided) The warning light (or symbol for versions with multifunction reconfigurable display) comes on when a fault is detected in the dusk sensor.</p>

Warning light	What it means
 <p>yellow</p>	<p>START&STOP SYSTEM ON (for versions/markets, where provided) The warning light comes on constantly to indicate activation of the Start&Stop system.</p>
 <p>yellow</p>	<p>START&STOP SYSTEM OFF (for versions/markets, where provided) The warning light or the symbol on the display come on to indicate deactivation of the Start&Stop system.</p>
 <p>yellow</p>	<p>iTPMS (for versions/markets, where provided) Low tyre pressure The warning light switches on constantly to indicate that the tyre pressure is lower than the recommended value, in order to guarantee long tyre life and low fuel consumption, or to indicate a slow loss of pressure. In this way the iTPMS warns the driver that one or more tyres may be flat and probably punctured. In this case it is advisable to restore the correct pressure value. Once the normal operating conditions of the car are restored, carry out the Tyre reset procedure. WARNING Do not continue driving with one or more flat tyres as handling of the car may be compromised. Stop the car, avoiding sharp braking and steering.</p> <hr/> <p>iTPMS failure/iTPMS temporarily deactivated The warning light flashes for about 75 seconds and then stays on constantly to indicate that the system is temporarily deactivated or faulty. The system goes back to normal operation when the operating conditions allow it. If this is not the case, carry out the Tyre reset procedure after restoring the normal operating conditions. If the malfunction warning persists, contact a Fiat Dealership as soon as possible.  53) 54)</p>









WARNING

- 51)** If, when the ignition key is turned to MAR, the  warning light does not come on, comes on constantly or flashes while driving, contact a Fiat Dealership as soon as possible. The operation of the  warning light may be checked by the traffic police using specific devices. Comply with the laws and regulations of the country where you are driving.
- 52)** The flashing  warning light on indicates possible  warning light faults. In this case, the  warning light may not indicate a possible problem with the airbag restraint system. Contact a Fiat Dealership immediately to have the system checked.
- 53)** If the system signals a pressure drop on a specific tyre, it is recommended to check the pressure on all four tyres. The iTPMS does not relieve the driver from the obligation to check the tyre pressure every month; it is not to be considered a system to replace servicing or a safety system. Tyre pressure must be checked with tyres cold. Should it become necessary for whatever reason to check pressure with warm tyres, do not reduce pressure even though it is higher than the prescribed value, but repeat the check when tyres are cold.
- 54)** The iTPMS cannot indicate sudden tyre pressure drops (for example when a tyre bursts). In this case, stop the vehicle, braking with caution and avoiding abrupt steering. The system only warns that the tyre pressure is low: it is not able to inflate them. Insufficient tyre inflation increases fuel consumption, reduces the tread duration and may affect the capacity to drive safely.

Green warning lights

Warning light	What it means
 <p data-bbox="236 314 290 333">green</p>	<p data-bbox="469 199 1123 218">SIDE LIGHTS AND DIPPED BEAM HEADLIGHTS/FOLLOW ME HOME</p> <p data-bbox="469 225 916 247">Side/tail lights and dipped beam headlights</p> <p data-bbox="469 250 1302 269">The warning light switches on when the side/tail lights or dipped headlights are turned on.</p> <hr/> <p data-bbox="469 300 644 319">Follow Me Home</p> <p data-bbox="469 325 1139 344">The warning light comes on when the "Follow me home" device is used.</p>
 <p data-bbox="236 471 290 490">green</p>	<p data-bbox="469 409 596 428">FOG LIGHTS</p> <p data-bbox="469 435 1094 454">The warning light comes on when the front fog lights are turned on.</p>
 <p data-bbox="236 617 290 636">green</p>	<p data-bbox="469 544 756 563">LEFT DIRECTION INDICATOR</p> <p data-bbox="469 570 1331 611">The warning light turns on when the direction indicator control stalk is moved downwards or, together with the right indicator, when the hazard warning light button is pressed.</p>
 <p data-bbox="236 762 290 781">green</p>	<p data-bbox="469 689 772 708">RIGHT DIRECTION INDICATOR</p> <p data-bbox="469 715 1382 757">The warning light turns on when the direction indicator control stalk is moved upwards or, together with the left indicator, when the hazard warning light button is pressed.</p>



Blue warning lights



Warning light	What it means
 blue	MAIN BEAM HEADLIGHTS The warning light switches on when the main beam headlights are turned on.

White warning lights

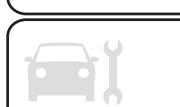







Warning light	What it means
 <p>white</p>	<p>ENERGY RECOVERY (for the 1.0 FireFly Hybrid version - for multifunction display only)</p> <p>The indicator light turns on during energy recovery (deceleration with a gear engaged) for recharging the auxiliary battery.</p> <p>In some circumstances, the indicator light may turn on briefly when shifting gear. This does not indicate a fault, so it is not necessary to go to a workshop.</p>









INSTRUMENT PANEL WARNING SYMBOLS*Red Symbols*





Symbol	What it means
	<p>OPEN DOORS / BONNET / BOOT (versions with colour display)</p> <p>On some versions, the symbols appear on the display when one or more doors, the tailgate or the bonnet (for versions/markets, where provided) are not properly closed. An acoustic warning is also emitted with the doors open and the car in motion.</p>
 <p>red</p>	<p>SPEED LIMIT EXCEEDED (for versions with colour display)</p> <p>The symbol appears on the display, together with an acoustic signal, when the vehicle exceeds the speed limit set in the Setup Menu (e.g. 120 km/h).</p>

Amber symbols



Symbol	What it means
 yellow	<p>DECAYED ENGINE OIL</p> <p>The warning light flashes. The warning light flashes for 3 minute cycles with the warning light off for intervals of 5 seconds until oil is changed.</p> <p>After the initial warning, each time the engine is started up, the warning light will continue to flash in the same mode, until the oil is changed.</p> <p>The flashing of the warning light should not be considered as a fault, it simply informs the customer that the oil needs to be changed following normal car use.</p> <p>Remember that engine oil deterioration is accelerated by using the car for short drives, preventing the engine from reaching its operating temperature.</p> <p> 55)  34)</p>
 yellow	<p>AUXILIARY LITHIUM BATTERY FAILURE (versions with colour display only) (for the 1.0 FireFly Hybrid version)</p> <p>The symbol comes on in the event of an all-wheel drive system failure. The charge state of the auxiliary battery will not be displayed in this case.</p> <p>Contact a Fiat Dealership as soon as possible.</p> <hr/> <p>HYBRID SYSTEM FAILURE (for the 1.0 FireFly Hybrid version)</p> <p>In the event of a hybrid system failure, the same symbol could also appear together with the  and/or  symbol. The charge state of the auxiliary battery will not be displayed in this case.</p> <p>Contact a Fiat Dealership as soon as possible.</p>
 yellow	<p>POSSIBLE ICE ON ROAD</p> <p>The symbol is displayed when the outside temperature falls to or below 3°C.</p>
 yellow	<p>PARKING SENSOR FAILURE (versions with colour display) (for versions/markets, where provided)</p> <p>The symbol appears on the display if there is a fault in the parking sensors.</p>



Symbol	What it means
 <p>yellow</p>	<p>START&STOP SYSTEM FAILURE (versions with colour display) (for versions/markets, where provided) The symbol comes on to indicate a Start&Stop system failure Contact a Fiat Dealership as soon as possible.</p> <hr/> <p>HYBRID SYSTEM FAILURE (for the 1.0 FireFly Hybrid version) The symbol also appears on the display in the event of a hybrid system failure. For this warning, the symbol could appear together with the  symbol/warning light and/or  symbol (versions with colour display only). The charge state of the auxiliary battery will not be displayed in this case. Contact a Fiat Dealership as soon as possible.</p>
 <p>yellow</p>	<p>SERVICE (SCHEDULED SERVICING) EXPIRED When the scheduled servicing is nearly due ("scheduled service deadline"), the display will show the symbol followed by the number of kilometres/miles until the car must be serviced. This is displayed automatically, with ignition key at MAR-ON, 2000 km (or equivalent value in miles) before servicing or, where provided, 30 days before servicing. It is also displayed each time the key is turned to MAR-ON or, for versions/markets, where provided, every 200 km (or equivalent value in miles). Go to a Fiat Dealership, where the "Service Schedule" operations will be performed and the message will be reset.</p>
 <p>yellow</p>	<p>ASR SYSTEM OFF (colour display) The symbol appears on the colour display when the ASR system is deactivated by pressing the ASR-OFF button on the dashboard. The LED in the button will light up at the same time.</p>
 <p>yellow</p>	<p>HILL HOLDER FAILURE (versions with colour display) (for versions/markets, where provided) The symbol appears on the display if there is a fault in the Hill Holder system. In this case, contact a Fiat Dealership as soon as possible.</p>
 <p>yellow</p>	<p>FUEL CUT-OFF SYSTEM (versions with colour display) The symbol appears on display if the fuel cut-off system intervenes. For the fuel cut-off system re-activation procedure, see the "Fuel cut-off system" paragraph, in the "In an emergency" chapter.</p>

Symbol	What it means
 yellow	FUEL CUT-OFF SYSTEM FAILURE (versions with colour display) The symbol appears on display in the event of a fault in the fuel cut-off system. Contact a Fiat Dealership.
 yellow	PASSENGER AIRBAG/SIDE BAGS DEACTIVATED The warning light indicates the passenger airbag protection status. If the warning light is off, passenger's airbag protection is active: to deactivate it, use the Setup Menu (in this case the LED lights up). When the engine is started (ignition key turned to MAR position), the warning light turns on for about 8 seconds, provided that at least 5 seconds have elapsed from when it was switched off. If not, contact a Fiat Dealership. If the engine is switched off/on again in less than 5 seconds the warning light may remain off. In this case, to check correct warning light operation, switch the engine off, wait for at least 5 seconds and switch the engine on again. The warning light may light up with various intensity levels depending on the car conditions. The intensity may also vary during the same key cycle.
 yellow	EXTERIOR LIGHTS FAILURE (versions with colour display) The symbol appears on the display when there is a fault in one of the following lights: <ul style="list-style-type: none"> <input type="checkbox"/> daytime running lights (DRL) <input type="checkbox"/> side lights <input type="checkbox"/> direction indicators <input type="checkbox"/> rear fog light <input type="checkbox"/> number plate lights. The anomaly relating to these lights could be: one or more blown bulbs, a blown protection fuse or a break in the relevant electric connection. It is advisable to contact a Fiat Dealership.
 yellow	BRAKE LIGHTS FAILURE (versions with colour display) The display will show the symbol if an anomaly in the brake lights is detected. The fault may be caused by a blown bulb, a blown protection fuse or a break in the relevant electrical connection. It is advisable to contact a Fiat Dealership.
 yellow	RAIN SENSOR FAILURE The symbol switches on in the case of failure of the rain sensor. Contact a Fiat Dealership as soon as possible.





Symbol	What it means
	<p>DUSK SENSOR FAILURE The symbol switches on in the case of failure of the dusk sensor. Contact a Fiat Dealership as soon as possible.</p>
	<p>SPEED LIMITER FAILURE The symbol switches on in the case of failure of the Speed Limiter device. Contact a Fiat Dealership as soon as possible to have the failure eliminated.</p>
	<p>FUEL RESERVE - LIMITED RANGE The warning light switches on when the ignition key is turned to MAR, but it should switch off after a few seconds. The warning light or the symbol switches on in the display when about 5 litres of fuel are left in the tank. The triangle on the right side of the symbol indicates the side of the car with the fuel filler. IMPORTANT If the warning light flashes or the symbol is constantly on, depending on the versions, there is a fault in the system. If this is the case, go to a Fiat Dealership to have the system checked.</p>



WARNING

55) If the warning light switches on, the degraded engine oil must be changed as soon as possible, and never more than 500 km from the first time that the warning light switches on. Failure to observe the above may result in severe damage to the engine and invalidate the warranty. The activation of this warning light is not related to the amount of oil in the engine. Therefore, never top up with oil when the warning light starts flashing.

56) If the warning light  (or the amber warning light , for versions/markets, where provided) switches on, the degraded engine oil must be changed as soon as possible, and never more than 500 km from the first time that the warning light switches on. Failure to observe the above may result in severe damage to the engine and invalidate the warranty. The activation of this warning light is not related to the amount of oil in the engine. Therefore, never top up with oil when the warning light starts flashing.



IMPORTANT

34) To avoid damaging the engine it is advisable to change the engine oil when the warning light  flashes. In this case, contact a Fiat Dealership.

MESSAGES ON INSTRUMENT PANEL

Messages	What it means
CITY	<p>"DUALDRIVE" ELECTRIC POWER STEERING SYSTEM ACTIVATION</p> <p>The indication CITY switches on when the "Dualdrive" electric power steering system is activated by pressing the "CITY" button on the dashboard. The CITY indication goes off when the button is pressed again.</p>
ECO	<p>TURNING ON THE ECO FUNCTION</p> <p>ECO is shown on the display with the "ECO" function is turned on by pressing the corresponding button on the dashboard. Pressing the button again, the message ECO will be switched off until the engine is started again. The ECO function will be on when the engine is started again. A dedicated screen instead of the "ECO" indication is displayed on some versions.</p>
DUALOGIC TRANSMISSION MESSAGES	<p>For versions equipped with "Dualogic" transmission, the following messages can be displayed:</p> <ul style="list-style-type: none"> <input type="checkbox"/> Reduce gear changes <input type="checkbox"/> Manual mode not available <input type="checkbox"/> Automatic method unavailable <input type="checkbox"/> Clutch overheating <input type="checkbox"/> Depress brake pedal <input type="checkbox"/> Press the brake pedal - delayed start-up <input type="checkbox"/> Gear not available <input type="checkbox"/> Manoeuvre not permitted <input type="checkbox"/> Press brake pedal and repeat manoeuvre <input type="checkbox"/> Positioning of the gear lever at N (neutral). <p> 35) 36)</p>



IMPORTANT

35) If the message is still shown in the display, contact a Fiat Dealership.

36) In order to keep the clutch in good condition, do not use the accelerator to hold the car stationary (e.g. when stopped on a slope); the clutch could be damaged if it overheats; use the brake pedal instead and only use the accelerator pedal when you decide to set off.



SAFETY

The chapter that you are about to read is very important: it describes the safety systems with which the car is equipped and provides instructions on how to use them correctly.

ACTIVE SAFETY SYSTEMS	91
DRIVING ASSISTANCE SYSTEMS	94
OCCUPANT PROTECTION SYSTEMS	96
SEAT BELTS	96
SBR SYSTEM (Seat Belt Reminder)	97
PRE-TENSIONERS	99
CHILD RESTRAINT SYSTEMS	101
SUPPLEMENTARY RESTRAINT SYSTEM (SRS) - AIRBAG	112

ACTIVE SAFETY SYSTEMS

The vehicle has the following active safety systems:

- ABS (Anti-lock Braking System);
- EBD (Electronic Brake force Distribution);
- MSR (Motor Schlepptomment Regelung);
- ESC (Electronic Stability Control);
- HH (Hill Holder);
- ASR (Antislip Regulation);
- HBA (Hydraulic Brake Assist);

For the operation of the systems, see the following description.

ABS (Anti-lock Braking System)

This system, which is an integral part of the braking system, prevents one or more wheels from locking and slipping in any road surface condition, irrespective of the intensity of the braking action, ensuring that the car can be controlled even during emergency braking thus optimising stopping distances.

The system intervenes during braking when the wheels are about to lock, typically in emergency braking or low-grip conditions, when locking may be more frequent.

The system also improves control and stability of the car when braking on a

surface where the grip of the left and right wheels varies, or on corners.

System intervention

A slight pulsing of the brake pedal and noise indicates the intervention of the ABS: this is completely normal when the system intervenes.

 57) 58) 59) 60) 61) 62) 63) 64) 65)

EBD (Electronic Brakeforce Distribution) SYSTEM

This system (which cannot be deactivated) recognises emergency braking conditions according to the speed of operation of the brake pedal and provides an additional hydraulic braking pressure to support that provided by the driver. This allows faster and more powerful operation of the braking system.

MSR (Motor Schlepptomment Regelung) SYSTEM

The MSR system is an integral part of the ABS, that intervenes, if there is a sudden change to a lower gear, restoring torque to the engine, thereby preventing excessive drive at the drive wheels which, especially in poor grip conditions, could lead to a loss in stability of the vehicle.

ESC (Electronic Stability Control) SYSTEM

This is an electronic system that controls vehicle stability in the event of tyre grip loss, helping maintain directional control.

The system is capable of recognising potentially dangerous situations in terms of the stability and intervenes automatically on the brakes in a differentiated manner for the four wheels in order to provide a stabilising torque.

The ESC system switches on automatically when the engine is started and cannot be switched off.

System intervention

It is signalled by the blinking of the instrument panel warning light , to inform the driver that the car is in critical stability and grip conditions.

 66) 67) 68) 69) 70) 71)

HH (Hill Holder) SYSTEM

This is an integral part of the ESC system and facilitates starting on slopes, activating automatically in the following cases:

- uphill: car stationary on a road with a gradient higher than 5%, engine running, brake pressed and gearbox in neutral or gear (other than reverse) engaged;



❑ downhill: car stationary on a road with a gradient higher than 5%, engine running, brake pressed and reverse gear engaged.

When setting off, the ESC system control unit maintains the braking pressure on the wheels until the engine torque necessary for starting is reached, or in any case for a maximum of 2 seconds, allowing your right foot to be moved easily from the brake pedal to the accelerator.

When the 2 seconds have elapsed, without starting, the system is automatically deactivated, gradually releasing the braking pressure.

During this release stage, the typical mechanical brake release noise can be heard, indicating that the car is about to move.

Moving the car on sloping roads

For optimal starting on very steep gradients, as follows:

- ❑ Press the brake pedal to activate the Hill Holder;
- ❑ completely press the clutch pedal;
- ❑ engage the gear;
- ❑ remove your foot from the brake pedal;
- ❑ completely press the accelerator pedal.

In this manner, the engine goes to the optimal rpm for taking off uphill. The Hill Holder remains engaged (car

braked) until the clutch is gradually released (holding the accelerator pedal pressed): at this point, the system switches off and the car starts moving.

The Hill Holder function switches off automatically if the car does not take-off within 2 seconds.

The manoeuvre makes it possible to avoid pressing the accelerator (because it must remain fully pressed during the manoeuvre) and to operate only the clutch, by gradually releasing it. Operating the handbrake is not necessary.

On less steep gradients, the system is active also with the accelerator pedal not completely pressed.



ASR (AntiSlip Regulation) SYSTEM

This is an integral part of the ESC system and automatically operates in the event of one or both drive wheels slipping, loss of grip on wet roads (aquaplaning) and acceleration on slippery, snowy or icy roads, etc. Depending on the slipping conditions, two different control systems are activated:

❑ if the slipping involves both drive wheels, the ASR system intervenes, reducing the power transmitted by the engine;

❑ if the slipping only involves one of the drive wheels, it also intervenes automatically, braking the wheel that is slipping.

System intervention

This is indicated by the flashing of the warning light on the instrument panel, to inform the driver that the car is in critical stability and grip conditions.

Manual engagement/release

The ASR comes on automatically whenever the engine is started. While driving, the ASR can be switched off and subsequently switched on again by pressing the (A) fig. 95 (ASR OFF). When the system is not active, the LED on the same button turns on and, on some versions, a message appears on the display.

If the ASR is turned off while driving, this is automatically reactivated at the following car starting. When travelling on snowy roads with snow chains, it may be helpful to turn the ASR off: in fact, in these conditions, the driving wheels skidding when moving off gives you better traction.



95

F0S0518

 74) 75) 76) 77) 78) 79)

HBA (Hydraulic Brake Assist) SYSTEM

It is an integral part of the ESC system.

The HBA system is designed to improve the car's braking capacity during emergency braking.

The system detects an emergency braking by monitoring the speed and strength with which the brake pedal is pressed, thereby applying the optimal brake pressure. This can reduce the braking distance: the HBA system therefore completes the ABS.

Maximum assistance of the HBA system is obtained pressing the brake pedal very quickly; in addition, the brake pedal should be pressed continuously during braking, avoiding intermittent presses, to obtain benefits from the system.

Do not reduce pressure on the brake pedal until braking is no longer necessary.

The HBA system is deactivated when the brake pedal is released.

 80) 81) 82) 83) 84)



WARNING

57) When the ABS cuts in and you feel the brake pedal pulsating, do not remove your foot, but keep the pedal pushed down; in doing so you, will stop in the shortest distance possible under the road conditions at the time.

58) To obtain the maximum efficiency of the braking system, a bedding-in period of about 500 km is needed: during this period it is better to avoid sharp, repeated and prolonged braking.

59) If the ABS system intervenes, this indicates that the traction of the tyres on the road is nearing its limit. You must slow down to a speed compatible with the available traction.

60) The ABS cannot overrule the natural laws of physics, and cannot increase the grip available according to the condition of the road.

61) The ABS cannot prevent accidents, including those due to excessive speed on corners, driving on low-grip surfaces or aquaplaning.

62) The capability of the ABS must never be tested irresponsibly and dangerously, in such a way as to compromise personal safety and the safety of others.

63) For the correct operation of the ABS, the tyres must of necessity be the same make and type on all wheels, in perfect condition and, above all, of the prescribed type and dimensions.

64) If the space-saver spare wheel (for versions/markets, where provided) is used, the ABS keeps operating. Always remember that the space-saver wheel, being smaller than the original wheel, provides less grip.

65) The ABS gets the most from the available grip, but it cannot improve it; you should therefore take every care when driving on slippery surfaces and not take unnecessary risks.

66) For the correct operation of the ESC system, the tyres must necessarily be of the same make and type on all wheels, in perfect condition and, above all, of the prescribed type and size.

67) The ESC functions even when the space-saver wheel is being used. Always remember that the space-saver wheel, being smaller than the original wheel, provides less grip.

68) ESC performance features must not induce the driver to take unnecessary or unfounded risks. Your driving style must always be suited to the road conditions, visibility and traffic. The driver is always responsible for road safety.

69) The ESC system cannot alter the natural laws of physics, and cannot increase grip, which depends on the condition of the road.

70) The ESC system cannot prevent accidents, including those due to excessive speed on corners, driving on low-grip surfaces or aquaplaning.



71) The capability of the ESC system must never be tested irresponsibly and dangerously, in such a way as to compromise personal safety and the safety of others.

72) The HH system is not a parking brake, therefore do not leave the car without activating the handbrake, switching off the engine, and engaging first gear, with the car parked in safe conditions.

73) There may be situations on small gradients (less than 8%), with car laden or a trailer attached to it (where provided), in which the HH system may not activate, causing a slight reversing motion and increasing the risk of collision with another vehicle or object. The driver is, in any case, responsible for safe driving.

74) For the correct operation of the ASR system, the tyres must of necessity be the same make and type on all wheels, in perfect condition and, above all, of the prescribed type and dimensions.

75) If the space-saver wheel (where provided) is used, the ASR system keeps operating. Always remember that the space-saver wheel, being smaller than the original wheel, provides less grip.

76) The ASR cannot overrule the natural laws of physics, and cannot increase the grip available according to the condition of the road.

77) The ASR system cannot prevent accidents, including those due to excessive speed on corners, driving on low-grip surfaces or aquaplaning.

78) The capability of the ASR must never be tested irresponsibly and dangerously, in such a way as to compromise personal safety and the safety of others.

79) Do not take unnecessary risks, even if your vehicle is fitted with an ASR system. Your driving style must always be suited to the road conditions, visibility and traffic. The driver is always responsible for road safety.

80) The HBA system cannot increase tyre grip on the road over the limits imposed by laws of physics: always drive carefully according to the conditions of the road surface.

81) The HBA system cannot prevent accidents, including those due to excessive speed on bends, travelling on low-grip surfaces or aquaplaning.

82) The HBA system is an aid for the driver, who must always pay full attention while driving. The responsibility always rests with the driver.

83) The capability of the HBA system must never be tested irresponsibly and dangerously in such a way as to compromise the safety of the driver, occupants or other road users.

84) When the HBA system intervenes, noises may be heard from the system. This is normal. In any case, while braking keep the brake pedal firmly depressed.

DRIVING ASSISTANCE SYSTEMS

iTPMS (indirect Tyre Pressure Monitoring System)

 85) 86) 87) 88) 89) 90)

DESCRIPTION

The car can be equipped with the iTPMS (indirect Tyre Pressure Monitoring System), which has wheel speed sensors to monitor the tyre inflation status. To access the iTPMS (fig. 96 - fig. 97) screens press the TRIP button.

The fig. 97 screen will be displayed only if one or more tyres are flat.

Correct tyre pressure (versions with colour display)

If pressure of all the tyres corresponds to the correct value, the display shows the following screen fig. 96.



96

F0S0498

Low tyre pressure

The system warns the driver if one or more tyres are flat by switching on the (!) warning light on the instrument panel. Furthermore, the display will show "KO" beside the tyres fig. 97 along with a warning message.



97

F080506

RESET PROCEDURE

The iTPMS needs an initial "self-learning" phase (with length depending on the driving style and road conditions: optimal conditions being driving on a straight road at 80 km/h for at least 20 minutes) which starts when the Reset procedure is carried out. The Reset procedure must be carried out:

- each time tyre pressure is modified;
- when even only one tyre is changed;
- when tyres are rotated/inverted;
- when the space-saver wheel is fitted. Before carrying out the RESET procedure, inflate the tyres to the rated

pressure values specified in the inflation pressure table (see "Wheels" paragraph in the "Technical Specifications" chapter).

If the RESET is not carried out, in all above cases, the (!) warning light may give false indications on one or more tyres. To carry out the RESET procedure, with the car stopped and the ignition key at MAR, use the setup menu (see the description of the "Display" paragraph).

At the end of the "Reset" procedure, the display will show the dedicated message, which indicates that self-learning has started.

If the iTPMS self-learning is not correctly executed, the message is not displayed.

OPERATING CONDITIONS

The system is active for speeds above 15 km/h.

In a few situations such as sporty driving, particular conditions of the road surface (e.g. icy, snowy, unsurfaced roads...) the signalling may be delayed or partial in detecting the contemporary deflation of more than one tyre.

Under special conditions (e.g. car loaded asymmetrically on one side, damaged or worn tyre, fitting the space-saver spare wheel, fitting snow chains, fitting different tyres on

the axles) the system may give false warnings or be temporarily deactivated. If the system is temporarily deactivated, the (!) warning light flashes for about 75 seconds and then remains on constantly.

This warning is displayed also after the engine has been switched off and then on again if the correct operating conditions are not restored.



WARNING

85) If the system signals a pressure drop on one or more tyres, it is recommended to always check the pressure on all tyres.

86) The iTPMS does not relieve the driver from the obligation to check the tyre pressure every month; the system does not replace servicing or operate as a safety system.

87) Tyre pressure must be checked with tyres cold. Should it become necessary for whatever reason to check pressure with warm tyres, do not reduce pressure even though it is higher than the prescribed value, but repeat the check when tyres are cold.

88) The iTPMS cannot indicate sudden tyre pressure drops (for example when a tyre bursts). In this case, stop the vehicle, braking with caution and avoiding abrupt steering.

89) The system only warns that the tyre pressure is low: it is not able to inflate them.



90) *Insufficient tyre inflation increases fuel consumption, reduces the tread duration and may affect the capacity to drive safely.*

OCCUPANT PROTECTION SYSTEMS

Some of the most important safety equipment of the car comprise the following protection systems:

- seat belts;
- SBR (Seat Belt Reminder) system;
- head restraints;
- child restraint systems;
- Front airbags and side bags.

Read the information given the following pages with the utmost care. It is of fundamental importance that the protection systems are used in the correct way to guarantee the maximum possible safety level for the driver and the passengers.

For the description of the head restraint adjustment see the "Head restraints" paragraph in the "Knowing your car" chapter.

SEAT BELTS

All vehicle seats are equipped with seat belts with three anchor points and a retractor. The reel mechanism operates locking the belt in the event of sharp braking or strong deceleration due to an impact.

This allows the belt strap to slide freely and to adapt to the body of the occupant. In the event of an accident, the belt will lock reducing the risk of impact inside the passenger compartment and of being projected outside the car. The driver is responsible for respecting, and ensuring that all the other occupants of the vehicle also respect, the local laws in force in relation to the use of the seat belts.

Always fasten the seat belts before setting off.

USING THE SEAT BELTS

The belt should be worn keeping the torso straight and rested against the backrest.

To fasten the seat belts, hold fastening tongue (A) fig. 98 and insert it into buckle (B), until it clicks into place.

On removal, if the belt jams, let it rewind for a short stretch, then pull it out again without jerking.

Press button (C) fig. 98 to release the belt.

Guide the belt while it is rewinding to prevent it from twisting. Through the retractor, the belt automatically adapts to the body of the passenger wearing it, allowing freedom of movement.

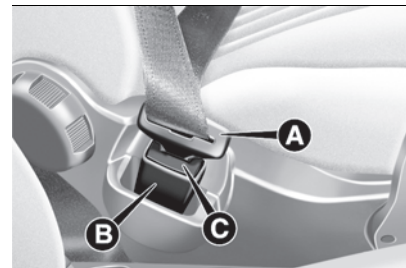

98

F0S0077

The retractor may lock when the car is parked on a steep slope: this is perfectly normal. Furthermore, the reel mechanism locks the belt if it is pulled sharply or in the event of sudden braking, collisions and high-speed bends.

The rear seat is fitted with inertia seat belts with three anchoring points and a retractor.

NOTE Wear the rear seat belts as shown in fig. 99.

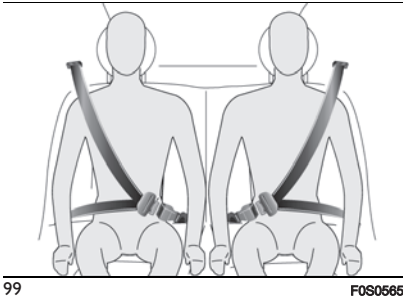

99

F0S0565

WARNING When putting the back seat to its normal position, make sure the seat belts are positioned so they are ready to use.

 91) 92)



WARNING

91) Never press button (C) fig. 98 when travelling.

92) Remember that in the event of an accident, the rear seat passengers not wearing seat belts are exposed to a very serious risk and also represent a serious danger for the front seat occupants.

SBR SYSTEM (Seat Belt Reminder)

(for versions/markets, where provided)

The SBR system warns the passengers of the front and rear (for versions/markets, where provided) seats if their seat belt is not fastened. The system indicates that seat belts are unfastened with visual warnings (warning lights on in the instrument panel and icons on the display) and/or an acoustic warning (see the following paragraphs).

NOTE Contact a Fiat Dealership to deactivate this acoustic warning permanently. The acoustic warning can be reactivated at any time through the display Setup Menu.

Front seat belt warning light behaviour

When the ignition device is turned to MAR, the  warning light ((A) fig. 100 for the TFT panel or (A) fig. 101 for the Comfort panel) comes on for a few seconds, regardless of the status of the front seat belts.

With car moving slower than 20 km/h, if the driver side seat belt or the passenger side seat belt (with occupant seated) is unfastened, the warning light  stays on constantly.

As soon as a speed threshold of 20 km/h is reached, with driver side

seat belt or the passenger side seat belt (with occupant seated) unfastened, an acoustic warning is activated simultaneously with warning light  flashing for about 105 seconds.

Once activated, this indication cycle stays active for the entire time if the car is moving faster than 8 km/h or if reverse gear is not engaged or until the seat belts are fastened.

If the car speed drops to less than 8 km/h or if reverse gear is engaged during the warning cycle, the tone will be interrupted and the warning light  switches on fixed. If the entire time has not elapsed and reverse gear is not engaged, the warning cycle is reactivated as soon as the car speed exceeds 20 km/h again.

Operation of rear seat belt icons for the TFT panel

The icons are shown on the display fig. 100

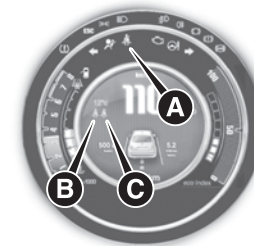

100

F0S0721



The displayed icons indicate:

(B): rear left seat belt;

(C): rear right seat belt.

With the car travelling as speed lower than 20 km/h, if a rear seat belt is unfastened, the icon stays on with fixed red light for a total of approximately 65 seconds.

The icons are displayed according to the corresponding rear seat belts and stay on for about 65 seconds from the last seat belt status change:

■ if the seat belt is fastened the corresponding icon will be green;

■ if the seat belt is unfastened the corresponding icon will be red.

If the car is travelling at a speed faster than 20 km/h and reverse is not engaged, if a rear seat belt is unbuckled, an acoustic warning is sounded when the icon blinks for approximately 35 seconds.

Successively, the acoustic warning is deactivated and the icon lights up with fixed light until the end of the entire cycle.

Furthermore, the icons light up to indicate the status of the seat belts whenever one of the front doors is opened.

WARNING As far as the rear seats are concerned, the SBR system will only indicate whether the seat belts

are unfastened or fastened, not the presence of any passengers.

The icons will activate a few seconds after the ignition device has been turned to MAR, regardless of the status of the seat belts (even if the seat belts are all fastened).

All icons light up when at least one belt changes from fastened to unfastened or vice versa and/or when one of the front doors is opened with the ignition device in the MAR position.

Operation of rear seat belt warning light for the Comfort panel

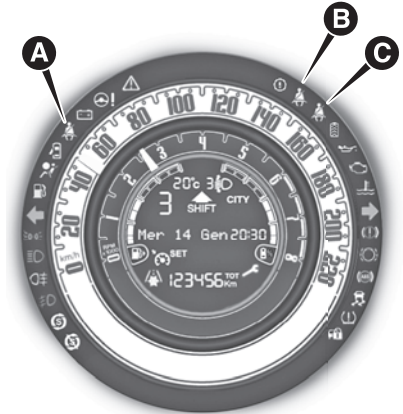

101

F0S0719

The warning lights shown on the instrument panel fig. 101 indicate:

(B): rear left seat belt;

(C): rear right seat belt.

With the car travelling as speed lower than 20 km/h, if a rear seat belt is unfastened, the warning light stays on with fixed amber light for a total of approximately 65 seconds.

The warning lights are displayed according to the corresponding rear

seat belt and stay on for about 65 seconds from the last seat belt status change:

- if the seat belt is fastened, the corresponding warning light will be off;
- if the seat belt is unfastened the corresponding warning light will be amber.

If the car is travelling at a speed faster than 20 km/h and reverse is not engaged, if a rear seat belt is unbuckled, an acoustic warning is sounded when the warning light blinks for approximately 35 seconds. Successively, the acoustic warning is deactivated and the warning light comes on with fixed light until the end of the entire cycle.

Furthermore, the warning lights come on to indicate that at least one belt has been unfastened whenever one of the front doors is opened or when a rear seat belt is unfastened with the ignition device in the MAR position.

WARNING As far as the rear seats are concerned, the SBR system will only indicate whether the seat belts are unfastened or fastened, not the presence of any passengers.

PRE-TENSIONERS

The car is equipped with front seat belts pretensioners, that reduce slack in the belts in the event of a severe frontal collision. This guarantees the perfect adherence of the seat belts to the occupants' bodies before the restraining action begins.

It is evident that the pretensioners have operated when the belt withdraws towards the retractor. The vehicle also features a second pretensioning device (fitted near the kick plate):

The activation of this device is indicated by the shortening of the metal cable.

A slight discharge of smoke may be produced during the activation of the pretensioner which is not harmful and does not involve any fire hazard. The pretensioner does not require any maintenance or lubrication:

any changes to its original conditions will invalidate its efficiency.

If, due to unusual natural events (floods, sea storms, etc.), the device has been affected by water or mud, have it replaced.

WARNING To obtain the highest degree of protection from the action of the pretensioner, wear the seat belt tight to the chest and pelvis.

 93) 94) 95)

 37)

LOAD LIMITERS

To increase occupant safety, the retractors of the safety belts contain a load limiter to dose the force acting on the chest and shoulders during the belt restraining action in the case of frontal collisions.

GENERAL INSTRUCTIONS FOR USING THE SEAT BELTS

 96)

Seat belts are also to be worn by pregnant women: the risk of injury in the case of impact is greatly reduced for them and the unborn child if they are wearing a seat belt.

Pregnant women must position the lower part of the belt very low down so that it passes over the pelvis and under the abdomen (see fig. 102).

While pregnancy increases, the driver must adjust both seat and steering wheel to have full control over the vehicle (pedals and steering wheel should be easily accessed).

The maximum clearance should be kept between the abdomen and the steering wheel.





102

F0S0415

The seat belt strap must not be twisted. The upper part must pass over the shoulder and cross the chest diagonally. The lower part must adhere to the pelvis (as shown in fig. 103) rather than the abdomen of the passenger. Never use devices (clips, clamps, etc.) that hold the seat belt away from your body.



103

F0S0079

Each seat belt must be used by only one person. Never travel with a child sitting on the passenger's lap and

a single belt to protect them both fig. 104. In general, do not place any objects between the person and the belt.



104

F0S0080

SEAT BELTS MAINTENANCE

For keeping the seat belts in efficient conditions, carefully observe the following warnings:

- always use the seat belt with the strap well stretched and not twisted; make sure that it is free to run without obstructions;
- check seat belt operation as follows: attach the seat belt and pull it hard;
- replace the seat belt after an accident of a certain severity even if it does not appear to be damaged. Always replace the seat belt if the pretensioners were deployed;
- prevent the retractors from getting wet: their correct operation is only guaranteed if water does not get inside

- replace the seat belt when it shows wear or cuts.



WARNING

93) The pretensioner may be used only once. Contact a Fiat Dealership to have it replaced after it has been deployed.

94) For maximum safety, keep the backrest upright, lean back into it and make sure the seat belt fits closely across your chest and pelvis. Always fasten the seat belts on both the front and the rear seats! Travelling without wearing seat belts will increase the risk of serious injury and even death in the event of an accident.

95) Removing or tampering with seat belt and pretensioner components is strictly prohibited. Any intervention on these components must be performed by qualified and authorised technicians. Always go to a Fiat Dealership.

96) If the belt has been sharply pulled, for example as the result of an accident, the seat belt, together with the anchoring devices, the anchoring device fixing screws and the pretensioner must be completely replaced. Even if the belt does not present any exterior signs of wear or damage, it may have lost its restraining properties.



IMPORTANT

37) Operations which lead to impacts, vibrations or localised heating (over 100°C for a maximum of six hours) in the area

around the pretensioners may damage or deploy them. Contact a Fiat Dealership should intervention be necessary on these components.

CHILD RESTRAINT SYSTEMS

CARRYING CHILDREN SAFELY

 97) 98) 99) 100)

For optimal protection in the event of an impact, all occupants must be seated and wearing adequate restraint systems, including newborn and other children! This prescription is compulsory in all EC countries according to EC Directive 2003/20/EC. Children below the height of 1.50 metres and up to 12 years must be protected with suitable restraint systems and be seated on the rear seats.

Statistics on accidents indicate that the rear seats offer greater safety for children. Compared with an adult, a child's head is larger and heavier in proportion to their body and the child's muscular and bone structures are not fully developed. Therefore, correct restraint systems other than adult seat belts are necessary to reduce as much as possible the risk of injuries in

the event of an accident, braking or sudden manoeuvre.

Children must be seated safely and comfortably. As far as the characteristics of the child seats used allow, you are advised to keep children in rearward facing child seats for as long as possible (at least until 3–4 years old), since this is the most protected position in the event of a collision.

The choice of the most suitable child restraint system depends on the weight and size of the child. There are various types of child restraint systems, which can be secured to the car by means of the seat belts or with the ISOFIX anchorages.

It is recommended to always choose the restraint system most suitable for the child; for this reason always refer to the Owner Handbook provided with the child restraint system, to be sure that it is of the right type for the children it is intended for.



WARNING

97) SEVERE DANGER! When a front passenger airbag is active, do not install rearward facing child restraint systems on the front passenger seat. Deployment of the airbag in a crash could cause fatal injuries to the child regardless of the severity of the collision. It is advisable to

always carry children in a child restraint system on the rear seat, which is the most protected position in the event of a collision.

98) On the sun visor there is a label with suitable symbols reminding the user that it is compulsory to deactivate the airbag if a rearward facing child restraint system is fitted. Always comply with the instructions on the passenger side sun visor (see the "Supplementary Restraint System (SRS) - Airbag" chapter).

99) Should it be necessary to carry a child on the passenger side front seat in a rear facing child restraint system, the passenger side front and side airbags must be deactivated through the display main menu, verifying deactivation by checking that the warning light  located in the central part of the dashboard has switched on. Move the passenger's seat as far back as possible to avoid contact between the child seat and the dashboard.

100) Do not move the front or rear seat if a child is seated on it or on the dedicated child restraint system.



In Europe the characteristics of child restraint systems are ruled by the regulation ECE-R44, dividing them into five weight groups:

Group	Age	Weight	Size class/Fixing
0	Indicatively up to 9 months	Up to 10 kg	ISO/L1
			ISO/L2
			ISO/R1
0+	Indicatively up to 2 years	Up to 13 kg	ISO/R1
			ISO/R2
			ISO/R3
1	Indicatively from 8 months to 4 years	9 kg - 18 kg	ISO/R2
			ISO/R3
			ISO/F2
			ISO/F2X
2	Indicatively from 3 to 7 years	15 kg - 25 kg	ISO/F3
			-
3	Indicatively from 6 to 12 years	22 kg - 36 kg	-

All restraint devices must bear the type-approval data, together with the control mark, on a label solidly fixed to the child restraint system which must never be removed.

Lineaccessori MOPAR® includes child restraint systems for each weight group. These devices are recommended having been specifically designed for Fiat vehicles.

WARNING For correct installation on the car, some universal child restraint systems require an accessory (base) sold separately by the restraint system's producer. Therefore, the manufacturer recommends checking with the retailer, by having a test fitting performed, if the desired child restraint system can be installed in the car before buying the seat.



INSTALLING A CHILD CARSEAT WITH SEATBELTS

 101) 102) 103) 104)

The Universal child restraint systems installed with the seat belts only are type-approved on the basis of the ECE R44 standard and are divided into various weight groups.

WARNING The figures are indicative and provided for assembly purposes only. Fit the child restraint system according to the instructions, which must be included.

WARNING Following an accident of a certain importance, it is recommended to replace both the child restraint system and the seat belt to which it was bound.

Group 0 and 0+

Children up to 13 kg must be carried with rearward facing child restraint system of a type as shown in fig. 105 which, supporting the head, does not induce stress on the neck in the event of sudden decelerations. The child restraint system is secured by the vehicle seat belts, as shown in and it must restrain the child in turn with its own belts.

0-13 kg



105

F0S0081

Group 1

Children weighing from 9 to 18 kg may be transported in forward facing child restraint systems fig. 106.

9-18 kg



106

F0S0412

Group 2

Children from 15 to 25 kg may use the vehicle seat belts directly fig. 107. In this case, the child restraint system is used to position the child correctly with respect to the seat belts so that the diagonal belt section crosses the child's chest and not the neck, and the

lower part is snug on the pelvis not the abdomen.

15-25 kg

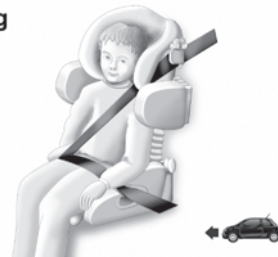

107

F0S0414

Group 3

For children between 22 and 36 kg, there are dedicated restraint systems that allow the seat belt to be worn correctly. The fig. 108 shows the correct child positioning on the rear seat.

22-36 kg



108

F0S0418

Children over 1.50 m in height can wear seat belts like adults.

INSTALLING AN ISOFIX CHILD RESTRAINT SYSTEM

 105) 106) 107) 108) 109)

The car is equipped with ISOFIX anchorages, a new standard which makes fitting a child restraint system quick, simple and safe.

The ISOFIX system lets you install the ISOFIX child restraining system without using the car seat belts but connecting them directly to the car seat with three anchorages in the car. Traditional child restraint systems can be fitted alongside ISOFIX child restraint systems on different seats in the same vehicle. Traditional child restraint systems can be fitted alongside ISOFIX child restraint systems on different seats in the same vehicle. To install an ISOFIX child restraint system, attach it to the two metal anchorages (A) fig. 109 located in the rear seat cushion and indicated by the  symbol in the point where the seat cushion meets the backrest, remove the parcel shelf and fix the upper strap (provided with the child restraint system) to the dedicated anchor (B) fig. 110 located at the bottom of the seat back.

fig. 111 shows an example of a Universal ISOFIX child restraint system for weight group 1.



109

F0S0133

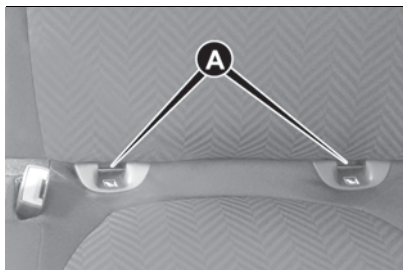
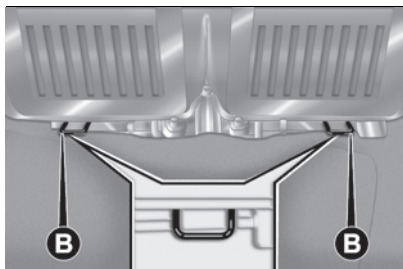

110

F0S0134

WARNING The diagram is indicative and for fitting purposes only. Fit the child restraint system according to the instructions, which must be included.

NOTE When a Universal ISOFIX child restraint system is used, only ECE R44 "ISOFIX Universal" (R44/03 or further upgrades) type-approved child restraint systems can be used.



111

F0S0132

The Universal Isofix "Duo Plus" child restraint system and the special "G 0/1" system are available from Lineaccessori MOPAR®.

For any further details on installation/use, refer to the instruction manual for the child restraint system.



SUITABILITY OF PASSENGER SEATS FOR I-SIZE CHILD RESTRAINT SYSTEM USE

(for versions/markets, where provided)

These child restraint systems, built and type-approved according to the i-Size (ECE R129) standard, ensure better safety conditions to carry children on board a car:

- ❑ the child must be transported rearward facing until 15 months;
- ❑ child restraint system protection is increased in the event of a side collision;
- ❑ the use of the ISOFIX system is promoted to avoid faulty installation of the child restraint system;
- ❑ efficiency in the choice of the child restraint system, which isn't made according to weight any more but according to the child's height, is increased;
- ❑ compatibility between the vehicle seats and the child restraint systems is better: the i-Size child restraint systems can be considered as "Super ISOFIX"; this means that they can be perfectly fitted in type-approved i-Size seats, but can also be fitted in ISOFIX (ECE R44) type-approved seats.



112

FOS0649

NOTE See the table shown on the following page to check whether your car is approved for installing i-Size child restraint systems.



WARNING

101) Child restraint systems with Isofix attachments are available for safe anchoring to the seat without using the car seat belts. For this type of seats see paragraph "Installation of an Isofix child restraint system" in this chapter.

102) Incorrect fitting of the child restraint system may result in an inefficient protection system. In the event of an accident the child restraint system may become loose and the child may be injured, even fatally. When fitting a restraint system for newborns or children, strictly comply with the instructions provided by the Manufacturer.

103) When the child restraint system is not used, secure it with the seat belt or with the ISOFIX anchorages, or remove

it from the car. Do not leave it unsecured inside the passenger compartment. In this way, in the event of sudden braking or an accident, it will not cause injuries to the occupants.

104) After installing a child restraint system, do not move the seat: always remove the child restraint system before making any adjustment.

105) If a Universal ISOFIX child restraint system is not fixed to all three anchorages, it will not be able to protect the child correctly. In a crash, the child could be seriously or fatally injured.

106) Fit the child restraint system when the car is stationary. The child restraint system is correctly secured to the brackets when you hear the click. Follow the instructions for assembly, disassembly and positioning that the Manufacturer must supply with the child restraint system.

107) Always make sure that the chest section of the seat belt does not pass under the arms or behind the back of the child. In the event of an accident the seat belt will not be able to secure the child, with the risk of injury, including fatal injury. Therefore the child must always wear the seat belt correctly.

108) Never use the same lower anchorage to attach more than one child restraint.

109) Fit the child restraint system according to the instructions, which must be included.

Child restraint system installation

The table provides guidelines on positioning child restraint systems on the car seats. Each child restraint system position complies with the UNECE standards



Seat number	Number of seats						
	1	2	3		4	5	6
			Airbag ENABLED	Airbag DISABLED			
Seat suitable for rearward facing child restraint systems (U)	X	X	NO	YES	YES	X	YES
Seat suitable for forward facing child restraint systems (UF)	X	X	YES ^(a)	NO	YES	X	YES
i-Size seat (i-U)	X	X	NO	NO	NO	X	YES **
Seat suitable for ISOFIX side fixtures (L1 / L2)	X	X	NO	NO	NO	X	NO
Seat suitable for ISOFIX rearward facing fixtures (R1/ R2 / R3) (IL)	X	X	NO	NO	NO	X	R2 only **



Seat number	Number of seats						
	1	2	3		4	5	6
			Airbag ENABLED	Airbag DISABLED			
Sear suitable for ISOFIX forward facing fixtures (F2/ F2X / F3) (IUF)	X	X	NO	NO	YES	X	YES
Sear suitable for forward facing Booster fixtures (B2/B3 fixtures)	X	X	NO	NO	NO (1)	X	Only B2

U = Position suitable for a "universal" child restraint system approved for this weight category.

UF = Position suitable for a "universal" forward facing child restraint system approved for this weight category.

IUF = Position suitable for an "ISOFIX" universal forward facing child restraint system approved for this weight category.

i-U = Position suitable for an i-Size "universal" forward facing or rearward facing child restraint system.

i-UF = Position suitable for an i-Size "universal" forward facing child restraint system.

IL = Position suitable for specific listed ISOFIX child restraint systems (CRS). These ISOFIX CRS are classified as "car-specific", "restricted use" and "semi-universal".

X = Not applicable. The seat is not approved for installation of child restraint systems.

(a) = With forward facing child restraint system, the seat must be positioned no more forward than the longitudinal halfway point.



** = Installation only possible by moving the corresponding front seat forward. In this configuration, the seat must not be occupied.

(1) = This seat is not approved for use with this category of child restraint systems. Nevertheless, it may still be possible to install this category of child restraint system. Therefore, check the compatibility of this vehicle with the identified child restraint system on the manufacturer's website.

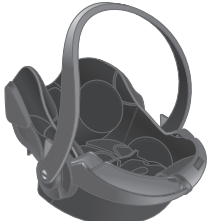

CHILD RESTRAINT SYSTEMS RECOMMENDED FOR YOUR CAR

In the markets for which they are available, Lineaccessori MOPAR® offers a complete range of child restraint systems to be fixed using the seat belt with three anchor points or the ISOFIX anchorages.

WARNING The manufacturer recommends fitting the child restraint system according to the instructions, which must be included.

Weight group	Child restraint system	Type of child restraint system	Child restraint system installation
Group 0+ : from birth to 13 kg from 40 cm to 80 cm		<p>BeSafe iZI Go Modular Fiat order code: 71808564</p>	<p>Universal/i-Size child restraint system. It must be installed facing rearwards, using the car seat belts only, or the dedicated i-Size base (which can be purchased separately) and the car ISOFIX anchorages. It must be fitted on the rear outer seats.</p>
		<p>BeSafe iZI Modular i-Size Base Fiat order code: 71808566</p>	



Weight group	Child restraint system	Type of child restraint system	Child restraint system installation
Group 0+/1: from 9 to 18 kg, from 67 cm to 105 cm		BeSafe iZi Modular iSize Fiat order code: 71808565	i-Size approved child restraint system. It must be installed on the car together with the iZi Modular i-Size Base (available separately). It can be installed facing forwards or facing backwards (refer to the child restraint system manual).
	+	+	
		BeSafe iZi Modular i-Size Base Fiat order code: 71808566	
Group 2: from 15 to 25 kg, from 95 cm to 135 cm		Britax Römer KidFix XP (for versions/markets, where provided) Fiat order code: 71807984	It can only be fitted facing forwards, using the three-point seat belt and the ISOFIX anchorages of the vehicle, if present. Fiat recommends installing it using the vehicle's ISOFIX anchor points. It must be fitted on the rear outer seats.

Weight group

Child restraint system

Type of child restraint system

Child restraint system installation

Group 3: from 22 to 36 kg
from 136 cm to 150 cm



Britax Römer KidFix XP (for versions/markets, where provided)
Fiat order code: 71807984

It can only be fitted facing forwards, using the three-point seat belt and the ISOFIX anchorages of the vehicle, if present. **Fiat recommends installing it using the vehicle's ISOFIX anchor points.** It must be fitted on the rear outer seats.



Safety 1st Manga E13 045072

It must only be installed facing forward, using the three-point seat belt



Main recommendations to carry children safely:

- ❑ Install the child restraint systems on the rear seat, which is the most protected position in the event of an impact.
- ❑ Keep children in rearward facing child restraint systems for as long as possible, until 3–4 years old if possible.
- ❑ If the passenger's front airbag is deactivated always check the permanent switching on of the specific warning light to make sure that it has actually been deactivated.
- ❑ Carefully follow the instructions supplied with the child restraint system. Keep the instructions in the vehicle along with the other documents and this handbook. Do not use second-hand child seats without instructions.
- ❑ Only one child is to be strapped into each restraint system; never carry two children using one child restraint system.
- ❑ Always check that the seat belts do not rest on the child's neck.
- ❑ Always check that the seat belt is well fastened by pulling on it.
- ❑ While travelling, do not let the child sit incorrectly or unfasten the belts.
- ❑ Never allow a child to put the belt's diagonal section under an arm or behind their back.

- ❑ Never carry children on your lap, even newborns. No-one can hold a child in the case of a crash.
- ❑ If the car has been involved in a road accident, replace the child restraint system with a new one. In addition, and depending on the type of child restraint system installed, replace the Isofix anchorages or the seat belt with which the child restraint system was connected.
- ❑ The rear headrest can be removed if needed to install a child restraint system. The headrest must always be fitted in the car if the seat is used by an adult passenger or a child sitting in a restraint system without a backrest.

SUPPLEMENTARY RESTRAINT SYSTEM (SRS) - AIRBAG

The car may be equipped with:

- ❑ front driver airbag;
- ❑ front passenger airbag;
- ❑ driver's side knee bag;
- ❑ driver and passenger front side bags for pelvis, chest and shoulder protection;
- ❑ window bags for head protection of front seat passengers and rear side seat passengers.

FRONT AIRBAGS



The front driver/passenger airbags and the driver's knee bag (for versions/markets, where provided) protect the front seat occupants in the event of frontal impacts of medium/high severity, by placing the bag between the occupant and the steering wheel or dashboard.

Therefore non-activation of airbags in other types of collisions (side impacts, rear shunts, roll-overs, etc.) does not indicate a system malfunction.

An electronic control unit will make the bag inflate in the event of a frontal impact.

The bag will inflate instantaneously placing itself between the front

occupants body and the structures which could cause injury. It will deflate immediately afterwards.

Front airbags are not a replacement of but complementary to the seat belts, which you are recommended to always wear, as specified by law in Europe and most non-European countries.

In the event of an impact, someone not wearing a seat belt could move forward and come into contact with a bag which is still opening. The protection offered by the bag is compromised in these circumstances.

The front airbags may fail to deploy in the following cases: frontal impact against highly deformable objects not involving the front surface of the car (e.g. wing collision against guard rail); in the case of the car wedging under other cars or protective barriers (e.g. under trucks or guard rails).

Failure to activate in the conditions described above is due to the fact that they may not provide any additional protection compared with seat belts, so their activation would be inappropriate. In these cases, non-deployment does not indicate a system malfunction.

The front airbags (driver, passenger, driver's knee bags) are designed and calibrated to protect front seat passengers wearing seat belts. Their

volume at the moment of maximum inflation fills most of the space between the steering wheel and the driver, between the lower post guard and the knees on passenger side and between the dashboard and the passenger. The airbags are not deployed in the event of minor frontal impacts (for which the restraining action of the seat belts is sufficient). Seat belts must always be worn. In the event of a frontal collision, they ensure the correct positioning of the occupant.

Driver's side front airbag



This consists of an instantly inflating bag contained in a special recess A in the centre of the steering wheel fig. 114.



113

FOS0586

Passenger front airbag

This consists of an instantly inflating bag contained in a special

compartment in the dashboard fig. 114: this bag has a larger volume than the driver's.



114

FOS0586

Passenger's front airbag and child restraint systems



Rearward facing child restraint systems must **NEVER** be fitted on the front seat since in the event of an impact the air bag activation may cause fatal injuries to the transported child.

ALWAYS comply with the instructions on the label stuck on both sides of the sun visor (fig. 115).





115

F0S0502

**WARNING**

110) Do not apply stickers or other objects on the steering wheel, on the dashboard in the passenger side airbag area, on the side upholstery on the roof and on the seats. Never put objects (e.g. mobile phones) on the passenger's side dashboard since they could interfere with correct inflation of the airbag and also cause serious injury to the passengers.

111) The airbag must be able to inflate without obstruction in the event of deployment. It is therefore recommended not to drive with the body bent forward, but to sit up resting your back and shoulders on the backrest of the seat. Adjusting the position of the seat so that you can reach and manoeuvre the steering wheel comfortably with your arms slightly bent being as far away as possible from the steering wheel. Being too close to the steering wheel when the airbag is deployed may cause serious injury.

112) When an active passenger airbag is fitted, DO NOT install rear facing child restraint systems on the front seat. Deployment of the airbag in an accident could cause fatal injuries to the child regardless of the severity of the impact.

113) When there is an active passenger airbag, DO NOT install rearward facing child restraint systems on the front seat. Deployment of the airbag in a crash could cause fatal injuries to the child regardless of the severity of the collision. It is advisable to always carry children in a child restraint system on the rear seat, which is the most protected position in the event of a collision.

Passenger's front airbag and child restraint systems: IMPORTANT

I	RISCHIO DI FERITE GRAVI O MORTALI. I seggiolini bambino che si montano nel verso opposto a quello di marcia non vanno installati sui sedili anteriori in presenza di air bag passeggero attivo.
GB	DEATH OR SERIOUS INJURY CAN OCCUR. NEVER use a rearward facing child restraint on a seat protected by an ACTIVE AIRBAG in front of it, DEATH or SERIOUS INJURY to the CHILD can occur
F	RISQUE DE MORT OU DE BLESSURES GRAVES. NE PAS positionner le siège pour enfant tourné vers l'arrière, en cas d'air bag passager actif.
D	Nichtbeachtung kann TOD oder SCHWERE VERLETZUNGEN zur Folge haben. Rückwärts gerichtete Kinderrückhaltesysteme (Babyschale) dürfen nicht in Verbindung mit aktiviertem Beifahrerairbag auf dem Beifahrersitz verwendet werden
NL	DIT KAN DODELIJK ZIJN OF ERNSTIGE ONGELUKKEN VEROORZAKEN. Plaats het kinderstoeltje niet ruggelings op de voorstoel wanneer er een airbag aanwezig is.
E	PUEDE OCACIONAR MUERTE O HERIDAS GRAVES. NO ubicar el asiento para niños en sentido inverso al de marcha en el asiento delantero si hubiese airbag activo lado pasajero.
PL	MOŻE GROZIĆ ŚMIERCIA LUB CIEŻKIMI OBRAŻENIAMI. NIE WOLNO umieszczać fotelika dziecięcego tyłem do kierunku jazdy na przednim siedzeniu w przypadku zainstalowanej aktywnej poduszki powietrznej pasażera.
TR	ÖLÜM VEYA AĞIR ŞEKİLDE YARALANMAYA SEBEP OLABİLİR. Yolcu airbağı aktif halde iken çocuk koltuğunu araç gidis yönüne ters biçimde yerleştirmeyin.
DK	FARE FOR DØDELIGE KVÆSTELSER OG LIVSTRUENDE SKADER. Placer aldrig en bagudvendt barnestol på passagerersædet, hvis passager-airbagen er indstillet til at være aktiv (on).
EST	TAGAJÄRJREKS VÕIVAD OLLA TÕSISE KEHAVIGASTUSED VÕI SURM. Turvapadja olemasolu korral ärge asetage lapse turvaistet sõidusuuna vastassuunas.
FIN	KUOLEMANVAARA TAI VAKAVIEN VAMMOJEN UHKA. Älä aseta lasten turvaistuinta niin, että lapsi on selkä menosuuntaan, kun matkustajan airbag on käytössä.
P	RISCO DE MORTE OU FERIMENTOS GRAVES. Não posicionar o banco para crianças numa posição contrária ao sentido de marcha quando o airbag de passageiro estiver activo.
LT	GALI IŠTIKTI MIRTIS ARBA GALITE RIMTAI SUSIŽEISTI. Nedėkite vaiko sėdynės atgretos nugarą į priekinį automobilio stiklą ten, kur yra veikiant keleivio oro pagalvė.
S	KAN VARA LIVSHOTANDE ELLER LEDA TILL ALLVARLIGA SKADOR. Placera aldrig en bakåtvänd barnstol i framsätet då passagerarsidans krockkudde är aktiv.
H	HALÁSOS VAGY SÜLYÖS BALESET KÖVETKEZHET BE. Ne helyezzük a gyermekülést a menetiránnyal szembe, ha az utas oldalán légszák működik.
LV	VAR IZRAISĪT NĀVI VAI NOPIETNAS TRAUMAS. Nenovietot mazuļa sēdekli pretēji braukšanas virzienam, ja pasažiera pusē ir uzstādīts gaisa spilvens.
CZ	HROZÍ NEBEZPEČÍ VÁŽNĚHO UBLIŽENÍ NA ZDRAVÍ NEBO DOKONCE SMRTI. Neumíst'ujte d'etskou sedačku do opačné polohy vůči směru jízdy v případě aktivního airbagu spolujedzce.
SLO	LAHKO PRIDE DO SMRTI ALI HUDIH POŠKODB. Otroškega avtomobilskega sedeža ne nameščajte v obratni smeri vožnje, če ima vozilo vgrajene zračne blazine za potnike.
RO	SE POATE PRODUCE DECESUL SAU LEZIUNI GRAVE. Nu aşezati scaunul de maşină pentru bebeluşi în poziţie contrară direcţiei de mers atunci când airbag-ul pasagerului este activat.
GR	ΜΠΟΡΕΙ ΝΑ ΠΡΟΚΛΗΘΟΥΝ ΘΑΝΑΤΟΣ Ή ΣΟΒΑΡΑ ΤΡΑΥΜΑΤΑ. Μην τοποθετείτε το καρεκλάκι αυτοκινήτου για παιδιά σε αντίθετη προς την φορά πορείας θέση σε περίπτωση που υπάρχει αερόσακος εν ενεργεία στη θέση συνεπιβάτη.
BG	ИМА ОПАСНОСТ ОТ СМЪРТ И СЕРИОЗНИ НАРАНЯВАНИЯ. Не поставяйте столчето за пренасяне на бебета в положение обратно на посоката на движение, при положение активно на въздушната възглавница за пътуване.
SK	MŮŽE NASTAŤ SMŤ ALEBO VÁŽNE ZRANENIA. Nedávajte autosedačku pre deti do polohy proti chodu vozidla, keď je aktívny airbag spolujazdca.
RUS	ТРАВМЫ И ЛЕТАЛЬНЫЙ ИСХОД. Детское кресло, устанавливаемое против направления движения, нельзя монтировать на месте переднего пассажира, если последнее оборудовано активной подушкой безопасности.
HR	OPASNOST OD TEŠKIH ILI SMRTONOSNIH OZLJEDA. Sjedala za djecu koja se montiraju u smjeru suprotnom od vožnje ne smiju se instalirati na prednja sjedala ako postoji aktivni zračni jastuk suvozača.
AS	قد تحدث حالات وفاة أو إصابات بالغة. لا تستخدم مقاعد الأمان الخاصة بالأطفال على مقعد مزود "بوسادة هوائية"، حيث إن الطفل قد يتعرض للوفاة أو لإصابة بالغة.

116

F081025



Driver knee bag

(for versions/markets, where provided)
It consists of an instantly inflating cushion contained in a special compartment (C) under the lower steering column guard fig. 117 at driver's knee level. It provides further protection to the driver in the event of a frontal impact.



117

F0S0105

Deactivating the passenger side airbags: front airbag and front side bag

 114) 115) 116)

(for versions/markets, where provided)
Warning light (A) fig. 118 in the centre of the dashboard will stay on constantly until the passenger's airbag and the front side bag are reactivated (for versions/markets, where provided).



118

F0S0389

WARNING To manually deactivate the passenger side front airbag and the front side bag (for versions/markets, where provided), see paragraph "Display" in the "Knowing the instrument panel" chapter.

SIDE BAGS - WINDOW BAGS

To help increase occupants protection in the event of a side collision, the car is equipped with front side bags (for versions/markets, where provided) and window bag (for versions/markets, where provided).

Side bags protect occupants from side-on crashes of medium/high severity by placing the bag between the occupant and the internal parts of the side structure of the car.

Non-activation of side bags in other types of collisions (front collisions, rear

shunts, roll-overs, etc.) is not a system malfunction.

Side bag

These comprise two instantly inflating bags located in the front seat backrests fig. 119, which protect the pelvis, chest and shoulder area of the occupants in the event of a side collision of medium/high severity.



119

F0S0087

Window bag

These consist of two "curtain" bags housed behind the side upholstery of the roof fig. 120 and covered with finishing elements, which protect the heads of front and rear occupants and of rear side seat occupants in the event of a side collision thanks to a wide bag deployment area.



120

F0S0106

Warnings

In the event of a side collision, the system provides best protection if the passenger sits on the seat in a correct position, thus allowing correct window bag deployment.

The front airbags and/or side bags may be deployed if the car is subject to heavy knocks or accidents involving the underbody area, such as for example violent shocks against steps, pavements or low obstacles, the car falling in big holes or dips in the road.

A small amount of dust will be released when the airbags are deployed.

The dust is not harmful and does not indicate the beginning of a fire.

Furthermore, the surface of the deployed bag and the interior of the car may be covered by a dusty residue: this may irritate skin and eyes. Wash with mild soap and water in the event of exposure. Every control, repair and

replacement operation concerning the airbags must only be carried out at a Fiat Dealership. If the car is scrapped, have the system deactivated at a Fiat Dealership.

Pretensioners, front airbags and side bags are deployed according to different logics on the basis of the type of collision. Failure to activate one or more of the devices does not indicate a system malfunction.

Should an accident occur in which any of the safety devices are activated, take the car to a Fiat Dealership to have the activated devices replaced and to have the whole system checked.

 117) 118) 119) 120) 121) 122) 123) 124) 125) 126) 127) 128)

AUXILIARY LITHIUM BATTERY DISCONNECTION

(for the 1.0 FireFly Hybrid version)

WARNING In the event of a collision that is serious enough to trigger the airbag, the auxiliary battery is automatically disconnected from the electrical system in order to prevent short circuits and/or fires.



In this case, the airbag warning light  will turn on together with the



engine failure warning light  on the instrument panel.

Contact a Fiat Dealership as soon as possible to have the electrical system checked.





WARNING

114) In some versions, in case of LED failure  (located on the plate of the instrument panel), the warning light  on the console turns on and the passenger side airbags are deactivated.

115) The  warning light indicates the passenger airbag protection status. If the warning light is off, passenger side protection is active: to deactivate it, use the Setup Menu (in this case the LED lights up). When the car is started (ignition key turned to MAR position), the warning light turns on for about 8 seconds, provided that at least 5 seconds have elapsed from when it was switched off. If not, contact a Fiat Dealership. If the engine is switched off/on again in less than 5 seconds the warning light may remain off. In this case, to check correct warning light operation, switch the engine off, wait for at least 5 seconds and switch the engine on again. The warning light may light up with various intensity levels depending on the vehicle conditions. The intensity may also vary during the same key cycle. When the ignition key is turned to MAR, the  warning light switches for few seconds, then if the passenger airbag is active it should switch off.



116) If a child must be carried on the front seat in a rearward facing child restraint system, it is compulsory to deactivate the passenger side front airbag, making sure that it is deactivated by checking the dedicated warning light on the instrument panel. Move the passenger's seat as far back as possible to avoid contact between the child restraint system and the dashboard.

117) A  warning light malfunction is indicated by activating an airbag fault symbol on the instrument panel display (or, for versions where provided, by activating a flashing generic fault warning light). In this case, the  warning light may not indicate a possible problem with the airbag restraint system. Contact a Fiat Dealership immediately to have the system checked.

118) Do not use seatcovers on front seats featuring side airbags.

119) Do not travel with objects in your lap, in front of your chest or held in your mouth (e.g., pipe, pencil etc.). They could cause severe injury if the airbag is deployed in a crash.

120) If the car has been stolen or in the case of attempt to steal it, if it has been subjected to vandalism or floods, have the airbag system checked by a Fiat Dealership.

121) The airbags may also be deployed when the car is not moving if it is hit by another moving car when the ignition key is inserted and turned to MAR, even if the engine is off. Therefore, even if the vehicle is stationary, when an active front passenger airbag is fitted, DO NOT install rearward facing child restraint systems on the front passenger seat. Deployment of the airbag following an impact could

cause fatal injuries to the child. Therefore, always deactivate the passenger side airbag when a rearward facing child restraint system is installed on the front passenger seat. The front passenger seat must also be positioned back as far as possible in order to prevent the child restraint system from coming into contact with the dashboard. Immediately reactivate the passenger airbag as soon as the child restraint system has been removed. Also remember that, if the key is turned to STOP, none of the safety devices (airbags or pretensioners) will be deployed in the event of collision. Non-deployment in such cases does not indicate a system malfunction.

122) When the ignition key is turned to MAR, the  warning light switches for few seconds, then if the passenger airbag is active it should switch off.

123) Do not wash the seats with water or pressurised steam (wash by hand or at automatic seat washing stations).

124) The airbag deployment threshold is higher than that of the pretensioners. For collisions in the range between the two thresholds, it is normal for only the pretensioners to be activated.

125) Do not affix rigid objects to the coat hooks or support handles.

126) The airbag does not replace seat belts but increases their efficiency. Furthermore, since front airbags are not deployed in low-speed frontal impacts, side impacts, rear shunts or roll-overs, the passengers are protected only by the seat belts which must therefore be fastened at all times.

127) Do not rest your head, arms or elbows on the door, on the windows or in the window bag area to prevent injury during deployment.

128) Never lean your head, arms or elbows out of the window.

STARTING AND DRIVING

We have now reached the "heart" of the car: let's see how to use the car to its full potential.

We'll look at how to drive safely in any situation, making it a welcome companion with our comfort and wallets in mind.

STARTING THE ENGINE	120
WHEN PARKED	121
MANUAL TRANSMISSION	122
DUALOGIC TRANSMISSION	123
DUALDRIVE ELECTRIC POWER STEERING	127
HYBRID SYSTEM.....	128
START&STOP SYSTEM (EXTENDED START&STOP)	129
SPEED LIMITER.....	132
ELECTRONIC CRUISE CONTROL	134
PARKING SENSORS	136
DRIVING TIPS.....	138
REFUELLING THE VEHICLE	140
TOWING TRAILERS.....	142



STARTING THE ENGINE

 129) 130)

 38) 39)

Before starting the car, adjust the seat, the interior rear view mirrors, the door mirrors and fasten the seat belt correctly.

Never press the accelerator pedal for starting the engine.

The Start&Stop, ECO and AUTO functions (where provided) are activated automatically whenever the engine is started.



PETROL VERSIONS

Starting the engine

Proceed as follows:

- engage the handbrake and put the gear lever in neutral;
- fully depress the clutch pedal without touching the accelerator;
- turn the ignition key to AVW and release it as soon as the engine starts.

If the engine does not start at the first attempt, return the ignition key to STOP before repeating the starting procedure.

If, with key at MAR, the  warning light or symbol on the display stays on together with the  warning light, it is advisable to turn the key to STOP and then back to MAR. If the warning

light remains on, try with the other keys provided with the car.

Contact a Fiat Dealership if you still cannot start the engine.

VERSIONS WITH DUALOGIC TRANSMISSION

 131)

The system allows the engine to be started both with a gear engaged and with the transmission in neutral (N). However, the brake pedal must always be pressed first if neutral is not engaged. It is therefore advisable to position the gear lever at N before starting the engine.

After starting:

- the gearbox automatically engages neutral (N);
- the lever remains in the same position as prior to switching off the engine;
- the display shows the letter N and, when the brake pedal is released, an acoustic warning signals any inconsistency between the position of the lever and the gear engaged;
- the following gears can be engaged: 1st, 2nd or reverse (R).

WARNING If start-up is requested with the gearbox in a position other than N and without the brake pedal

pressed, the display shows a dedicated message (see "Warning lights and messages"). In this case, repeat the starting manoeuvre, pressing the brake pedal.

WARNING If start-up is requested with the gearbox faulty, carry out the "Delayed start-up" procedure (see "Warning lights and messages" paragraph): turn the key to the AVV position for at least 7 seconds with the brake depressed and the engine will start. The system will remain in recovery mode (highest gear permitted 3rd, automatic mode not available). If the engine does not start, contact a Fiat Dealership.

WARNING With the engine off, when the driver's door is opened, the system activates the hydraulic components so that they are prepared for the subsequent engine starting.

LPG VERSIONS

The engine is only started with LPG if the Start&Stop system is activated and LPG is selected.

 40)

WARMING UP THE ENGINE JUST AFTER IT HAS STARTED



Proceed as follows:

- drive off slowly, letting the engine turn at medium revs. Do not accelerate abruptly;
- do not demand full performance at first.

Wait until the engine coolant temperature gauge starts moving.

SWITCHING OFF THE ENGINE

Turn the ignition key to STOP while the engine is idling.



WARNING After a taxing drive, you should allow the engine to "catch its breath" before turning it off by letting it idle to allow the temperature in the engine compartment to fall.



WARNING

129) It is dangerous to run the engine in enclosed areas. The engine consumes oxygen and engine exhaust contains carbon dioxide, carbon monoxide and other toxic gasses.

130) Remember that the brake servo and electric power steering are not operational

until the engine has been started, therefore much effort than usual is required on the brake pedal and steering wheel.

131) If the engine fails to start with a gear engaged, the potentially dangerous situation due to the fact that the transmission is automatically placed in neutral will be signalled by an acoustic warning.



IMPORTANT

38) It is advisable not to demand maximum performance from your car (e.g. excessive acceleration, long distances at maximum rpm, excessively intense braking, etc.) when it is first used.

39) When the engine is off, never leave the key turned to MAR to prevent useless current absorption from draining the conventional battery.

40) There must therefore always be enough petrol in the tank to protect the petrol pump and to guarantee temporary switching from LPG to petrol operating mode.

41) Never, under any circumstances, jump start the engine by pushing, towing or coasting downhill. This could cause fuel to flow into the catalytic converter and damage it beyond repair.

42) A quick burst on the accelerator before stopping the engine serves no practical purpose; it wastes fuel and is especially damaging to turbocharged engines.

WHEN PARKED

When parking and leaving the car, proceed as follows:

- engage a gear (1st gear if facing uphill or reverse if facing downhill) and leave the wheels turned;
- stop the engine and engage the handbrake;
- always remove the ignition device. Block the wheels with a wedge or a stone if the car is parked on a steep slope. Do not leave the ignition key at MAR to avoid draining the conventional battery. Always remove the key when you leave the car.

Versions with Dualogic transmission

To park safely it is essential to engage 1st gear or reverse (R), with your foot on the brake pedal and, if there is a gradient, to operate the handbrake. Before releasing the brake pedal, wait until P appears on the display.

WARNING NEVER leave the car with the gearbox in neutral (or, on versions equipped with automatic transmission, before placing the gear lever at P).

HANDBRAKE

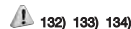

The handbrake lever fig. 121 is located between the two front seats.



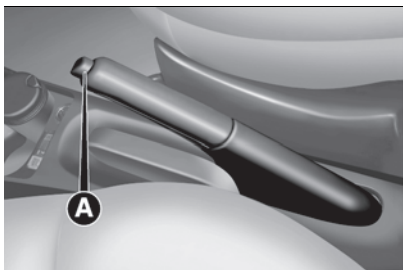

121

F0S0048

Handbrake engagement

To use the handbrake pull the lever upwards until the car cannot be moved. When the handbrake is on and the ignition key is at MAR, the instrument panel warning light (⚠) will come on.

Handbrake disengagement

Proceed as follows to release the handbrake:

- slightly lift the lever and press release button (A) fig. 121;
- keep the button (A) pressed and lower the lever. The (⚠) warning light in the instrument panel will switch off. Press the brake pedal when carrying out this operation to prevent the car from moving accidentally.



WARNING

132) *The car should be braked after a few clicks of the lever, if it is not, contact a Fiat Dealership to have it adjusted.*

133) *Never leave children unattended in the car. Always remove the key from the ignition when leaving the car and take it with you.*

134) *In the case of parking manoeuvres on roads on a gradient, the front wheels must be steered towards the pavement (when parking downhill), or in the opposite direction if the car is parked uphill. Block the wheels with a wedge or a stone if the car is parked on a steep slope.*

MANUAL TRANSMISSION

(for versions/markets, where provided)

⚠ 135)

⚠ 43)

To engage the gears, press the clutch pedal fully and put the gear lever into the required position (the diagram for gear engagement is shown on the grip fig. 122).

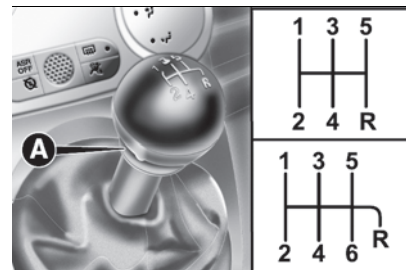

122

F0S0597

For cars provided with 6-speed gearbox, to engage the 6th gear, operate the lever by pressing it towards the right in order to avoid engaging the 4th gear by mistake. The same applies to the shift from 6th to 5th gear. To engage reverse R from neutral, lift the sliding ring (A) fig. 122 under the knob and at the same time move the lever to the rightwards and then back.

WARNING Reverse can only be engaged when the car is completely stationary. With the engine running, wait for at least 2 seconds with the clutch pedal fully depressed before engaging reverse to prevent damage to the gears and grating.

WARNING The clutch pedal should be used only for gear changes. Do not drive with your foot resting on

the clutch pedal, however lightly. For versions/markets where provided, the electronic clutch control could cut in, interpreting the incorrect driving style as a fault.



WARNING

135) Press the clutch pedal fully to shift gears correctly. It is therefore essential that there is nothing under the pedals: make sure the mats are lying flat and do not get in the way of the pedals.



IMPORTANT

43) Do not drive with your hand resting on the gear lever as the force exerted, even if slight, could lead over time to premature wear of the gearbox internal components.

DUALOGIC TRANSMISSION

(for versions/markets, where provided)

WARNING For the correct use of the system only use your right foot to operate the pedal unit.



OPERATING MODE MANUAL MODE

In this mode, the driver decides when to shift gear;

Proceed as follows:

- press the brake pedal;
- start the engine;
- push the lever (A) fig. 123 for the gearbox towards (+) to engage the first gear (if it is coming from N or R, simply place the lever in the middle position) or in R to engage reverse gear;



123

F0S0576

- release the brake pedal and press the accelerator pedal;
- in driving conditions, push lever A of the gearbox towards (+) to engage the next gear up or towards (-) to engage the next gear down.

AUTOMATIC MODE (AUTO)

In this mode, the system directly decides when to shift gear. Proceed as follows:

- press the brake pedal;
- start the engine;
- push the gear lever to A/M to engage automatic mode or to R to engage reverse gear;
- release the brake pedal and press the accelerator pedal.

ECO function

The ECO function, which optimises the gearbox and reduces fuel consumption, can only be activated with automatic mode on. To switch the function on, press the button (E) fig. 123 on the gearbox trim.

With the ECO function active, the display will show the current gear and the words AUTO and ECO; the system will select the most suitable gear depending on the car speed, engine rpm and intensity with which the accelerator pedal is pressed, with the aim of limiting fuel consumption.



The ECO and AUTO functions are activated automatically whenever the engine is started.

CONTROL LEVER

 46) 47)

The control lever (A) fig. 123 on the dashboard is of the multi-stable floating type, in other words it has three stable and three unstable positions.

The three stable positions correspond to neutral (N), reverse (R) and the central position located between the unstable positions (+) and (-).

The unstable positions, in other words those that are abandoned as soon as the lever is released, are the positions for requesting a higher gear (+), requesting a lower gear (-) and requesting automatic operating mode (A/M).

Returning to manual mode is achieved by moving the lever back to A/M position.

The lever can be moved with or without the brake pedal pressed with the vehicle stationary and the key removed.

The system does not carry out any action after the lever has been moved and remains in the gear memorised before the key was removed.

WARNING With the engine started, any error between the lever position

and the gear actually engaged is signalled by a buzzer until consistency is restored.

MANUAL OPERATION (MANUAL)

In this operating mode, the driver is responsible for choosing the best gear ratio to engage, depending on the car operating conditions.

To change gear, proceed as follows:

move the lever to position (+) to engage a higher gear;

or

move the lever to position (-) to engage a lower gear.

If the gear change request may adversely affect the correct operation of the engine and the transmission, the system will not allow it. In such cases the system will warn the driver of the impossibility of changing gear by means of a buzzer.

The system will also automatically change down if the engine is idling (e.g. during deceleration).

STEERING WHEEL PADDLES

(for versions/markets, where provided)

 47) 45)

Shifting can be managed sequentially via the shift paddles on the steering wheel fig. 124.

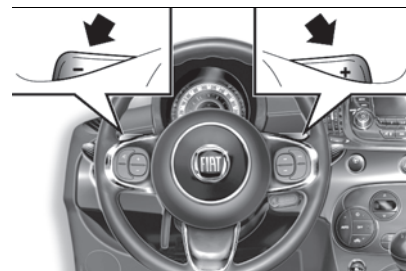

124

F0S0577

To use the steering wheel paddles, the gear lever must be in the middle position between + and -:

pulling lever + (towards driver): engage higher gear (see example fig. 125);

pull the paddle - (towards driver): shift down.

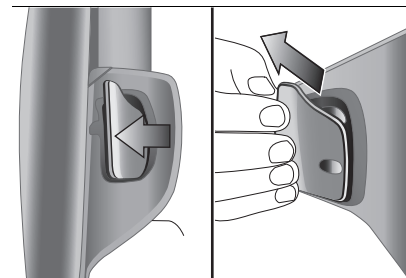

125

F0S1015

NOTE Shifting up (or down) is only permitted if the engine rpm allow it.

NOTE For correct use of the system, you are advised only to use your right foot to operate the pedal unit.

AUTOMATIC OPERATION (AUTO)

To activate/deactivate automatic operation (AUTO), push lever (A) fig. 123 to A/M position.

The activation is signalled on the multifunction display (B) fig. 126 or on the colour display (C) fig. 127 (for versions/markets, where provided), which shows the wording AUTO and the gear engaged.

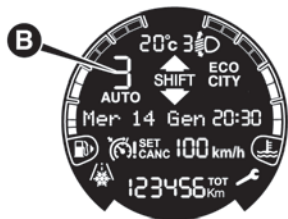

126

F0S0656



127

F0S0500

In AUTO mode the system changes gear depending on the car speed, the engine rpm and the intensity with which the accelerator pedal is pressed.

A gear change can be requested using the control lever without having to switch off this mode: this function, known as “gear suggestion”, suspends the automatic mode for the time necessary to make the gear selection requested by the driver.

“Kick Down” function

If necessary (e.g. when overtaking), the system downshifts one or more gears when the accelerator pedal is depressed beyond the point where it becomes stiff (and if the rpm allow it) in order to provide suitable power and torque for the acceleration requested by the driver.

In this way engine rpm and power supplied will increase, and will

automatically be restored once in normal conditions.

WARNING The use of the “Kick Down” function is recommended only when overtaking or accelerating quickly, in order not to increase fuel consumption.

INFORMATION ON THE DISPLAY

When the ignition key is turned to the MAR-ON position, after about 1 second, the display will show the gear engaged and the last mode used (AUTO or MANUAL):

- N** = neutral;
- 1** = first gear;
- 2** = second gear;
- 3** = third gear;
- 4** = fourth gear;
- 5** = fifth gear;
- R** = reverse.

When the ECO function is used, the message ECO (A) fig. 128 appear on the multifunction display; if the car is provided with colour display (for versions/markets, where provided), a coloured digital scale dedicated to this function will appear.





128

F0S0657

WARNING If 10 seconds elapse with the ignition key at MAR-ON and the display does not show the gear engaged, turn the key to STOP, wait for the display to turn off and then repeat the manoeuvre. If the fault persists, contact a Fiat Dealership.

MOVING THE CAR

Moving the car (setting off), is permitted in 1st gear, in 2nd gear (recommended on road surfaces with poor grip) or in reverse (R).

To engage 1st gear, proceed as follows:

- press the brake pedal;
- with the lever in (N) or (R), move the lever to the middle position or, with lever already in middle position, move the lever towards (+);

- release the brake pedal and press the accelerator pedal (fully depressing the pedal quickly to the end of travel position and switching off the ASR, if fitted, results in a “lively” departure).

The 1st or 2nd gear can be engaged using the gear lever and, with the brake pedal pressed, the lever on the steering wheel (+) (for versions/markets, where provided).

When setting off on a medium-steep incline, it is advisable to use the handbrake.

To engage 2st gear, proceed as follows:

- press the brake pedal;
- with the lever in (N) or (R), move the lever to the middle position and then towards (+) or, with lever already in middle position, move it towards (+) twice;
- release the brake pedal and press the accelerator pedal. It is possible to engage 1st or 2nd gear with the lever in the middle position and the brake pedal pressed, using the lever (+) located behind the steering wheel (for versions/markets, where present).

When setting off on a medium-steep incline, it is advisable to use the handbrake.

To engage reverse gear (R), proceed as follows:

- press the brake pedal (car

- completely stationary);
- place the lever in (R);
- release the brake pedal and press the accelerator pedal.

WARNING With the car running, the request is accepted and executed if the car speed drops below 3 km/h within 1.5 seconds from the request: if the request is not executed, the system will maintain the gear engaged or, if the speed of the car drops below 10 km/h, will put the transmission in neutral (N) and the manoeuvre will have to be repeated.

ACOUSTIC WARNING

For safety reasons, there is a buzzer warning when parking the car with the gearbox in neutral (N) (the warning is heard when the ignition key is turned to the STOP position). Letter “N” will blink on the display at the same time.

With the car stationary, the engine running and 1st, 2nd or reverse (R) gear engaged, the system activates the acoustic signal and automatically puts the transmission in neutral (N) when:

- the accelerator and/or brake pedal are not operated for at least 3 minutes;
- the brake pedal is pressed for longer than 10 minutes;

- ❑ the driver's door is opened and the accelerator pedal or the brake pedal are not operated for at least 1.5 seconds;
- ❑ an anomaly has been detected in the transmission.

GENERAL WARNINGS

- ❑ With car stationary and gear engaged, always keep the brake pedal pressed until you decide to set off, then release the brake and accelerate gradually.
- ❑ During prolonged stops with the engine running, it is advisable to keep the transmission in neutral (N).
- ❑ In order to safeguard the efficiency of the clutch, do not use the accelerator to keep the car stationary (e.g. when stopped on an incline); if the clutch overheats it could be damaged. Use the brake pedal or the handbrake instead and use the accelerator pedal only when you decide to set off.
- ❑ Only use second gear when you need greater control when setting off for manoeuvres on surfaces with poor grip.
- ❑ If, with reverse gear (R) engaged, you have to engage first gear or vice versa, only do this when the car is completely stationary and with the brake pedal pressed.

- ❑ Although it is highly inadvisable, if you are driving downhill and, for unexpected reasons, you let the car move forward with the gearbox in neutral (N), when there is a request to engage a gear, depending on the speed of the car, the system will automatically engage the best gear for the correct transmission of drive torque to the wheels.
- ❑ When necessary, with the engine switched off it is possible to engage 1st gear or reverse (R) with key in the MAR-ON position and the brake pressed. In this case, gear shifts must be carried out allowing at least 5 minutes to elapse between one gear shift and the next to safeguard the operation of the hydraulic system and the pump in particular.
- ❑ Fully depressing the accelerator pedal quickly and deactivating the ASR (pressing the button on the dashboard) if present, allows a "lively" start.
- ❑ For uphill starts, accelerating gradually but fully immediately after releasing the handbrake or the brake pedal allows the engine to greatly increase the number of revs and tackle the steepest gradients with more torque at the wheels.



IMPORTANT

- 44)** Avoid keeping your hand on this lever except during gear change or AUTO/MANUAL mode requests.
- 45)** If the transmission is faulty, contact a Fiat Dealership as soon as possible to have the system checked.
- 46)** Avoid keeping your hand placed on this lever in between gear changes or Auto/Manual mode.
- 47)** Using the paddles incorrectly (paddles pushed towards the dashboard) could break them.

DUALDRIVE ELECTRIC POWER STEERING

(for versions/markets, where provided)

WARNING When turning the ignition key quickly, full power steering functionality can be achieved after a few seconds.

For some versions the control to activate the Dualdrive electric power steering is replaced by the control to activate the ECO function.

Turning on/off (CITY function)

Press button (A) fig. 129 to turn the function on/off.





129

F0S0650

When the function is active, the CITY text on the display turns on.

When the CITY function is on, the steering wheel effort is lighter, making parking easier: therefore, this function is particularly useful for driving in city centres.

To deactivate the function press the button again.

 136) 137)

WARNING During parking manoeuvres requiring a lot of steering, the steering may become harder: this is normal and is due to the intervention of the system to protect the electric steering motor from overheating, so no repair is required. When the car is used again later on, the power steering will work normally.

WARNING In the event of electric power steering system failure, the car can be driven with mechanical steering.

ECO FUNCTION

(for versions/markets, where provided)

With the ignition key at MAR, press button ECO (B) fig. 129 to activate the function. The word ECO on the display will light up or, according to the version, a dedicated screen will be displayed.

When the function is activated, the car is set for city driving, characterised by less effort on the steering wheel (Dualdrive system on) and reduced fuel consumption.

Press the button again to deactivate the function.

This function is not stored, so the system will restart with the function on when the engine is restarted.



WARNING

136) *It is absolutely forbidden to carry out any after-market operation involving steering system or steering column modifications (e.g.: installation of anti-theft device) that could badly affect performance and safety, invalidate the warranty and also result in non-compliance of the car with type-approval requirements.*

137) *Before starting any servicing operation, stop the engine and remove the key from the ignition switch to operate the steering lock, particularly when the wheels do not touch the ground. If this is not possible (for example if the key needs to be turned to MAR or the engine must be running), remove the main fuse that protects the electric power steering.*

HYBRID SYSTEM



Your car has a hybrid system, which uses an electric motor that is mechanically coupled to the thermal engine (via a dedicated belt) and powered by an auxiliary lithium battery (12 V). The electric motor contributes to driving the car forward, together with the heat engine when there is a certain acceleration demand, and charges the lithium battery when the car decelerates.

The hybrid system uses a BSG (Belt Starter Generator) electric motor working both as a generator (alternator) and as a starter motor.

NOTE The system does not operate continuously, but is activated according to the car status, driving conditions (acceleration, braking, deceleration

and starting) and road conditions (e.g. gradient).

ENERGY RECOVERY DURING DECELERATION ("e-COASTING"/"e-BRAKING" functions)

During deceleration with a gear engaged, the BSG (Belt Starter Generator) recharges the lithium auxiliary battery and the traditional lead battery. When the accelerator pedal is released with the gear is engaged, the BSG acts as an engine brake (e-COASTING function). This contribution is increased by pressing the brake pedal at the same time (e-BRAKING function). The recovered energy is made available later, helping to save fuel.

NOTE If the conventional battery is flat, there is no energy recovery to the auxiliary battery, and so the Trip Computer "Energy Flows" screen on the instrument panel (for versions with colour display only) does not display the relative recharging flows.

ACCELERATION ASSIST FUNCTION ("e-ASSIST" function)

In general, during pickup from low engine speeds, the hybrid system shares the torque between the electric motor and thermal engine when

necessary, thereby reducing the output power of the thermal engine in order to optimise consumption.

HEAT ENGINE RESTART BY START&STOP ("EXTENDED S&S" FUNCTION)

The new system automatically switches the thermal engine on and off using the Start&Stop ("EXTENDED S&S") function. In this way, the efficiency of the car is increased, by reducing consumption, harmful gas emissions and noise pollution. In addition, the Start&Stop system restarts the heat using either the electric motor (BSG) or the starter motor, according to the version.

START&STOP SYSTEM (EXTENDED START&STOP)



(for versions/markets, where provided)

The Start&Stop system automatically stops the engine each time the car is stationary and starts it again when the driver wants to move off.

In this way, the car efficiency is increased, by reducing consumption, emission of harmful gases and noise pollution.

OPERATING MODE

Stopping the engine

With manual transmission: with the car stationary, the engine stops with the transmission in neutral and the clutch pedal released.

With Dualogic transmission: the engine stops if the car is at a standstill and the brake pedal is pressed. This condition can be maintained even if the brake pedal is not depressed, if the gear lever is in position N (Neutral).

For 1.0 FireFly Hybrid versions: when the speed drops below 30 km/h and the conditions permit, the GSI (Gear Shift Indicator) advises shifting to neutral (N) by displaying the letter "N" on the instrument panel display. If the conditions permit, the heat engine turns



off after shifting to neutral in order to reduce consumption. When the speed varies with the engine off, the GSI system advises the best gear to engage if you operate the clutch to restart the engine.

NOTE The engine can only be stopped automatically over about 10 km/h, to prevent the engine from being repeatedly stopped when driving at walking pace.

The warning light or  symbol on the instrument panel come on to indicate that the engine has stopped.

Restarting the engine

With manual transmission: press the clutch pedal.

With Dualogic transmission: if the gear lever is in position N (Neutral), place it in any other gear, otherwise release the brake pedal or move the gear lever to +, - or R (Reverse).

For 1.0 FireFly Hybrid versions: press the clutch pedal. For further information about the GSI (Gear Shift Indicator) display, see the "Display" chapter in the "Knowing the instrument panel" section.

MANUAL SYSTEM ACTIVATION/DEACTIVATION

The system can be activated/deactivated by pressing the button (A) fig. 130 on the dashboard.

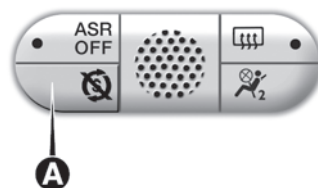

130

F0S0519

With the system deactivated, the  warning light on the instrument panel comes on.

Start&Stop mode will be active whenever the engine is started.

MISSED ENGINE STOPPING CONDITIONS

When the system is active, for a higher comfort and safety, and to reduce emissions, the engine does not stop in some conditions, such as:

- engine still cold
- especially cold outside temperature
- conventional battery and auxiliary lithium battery (for the 1.0 FireFly Hybrid version) not sufficiently charged
- driver's door not shut
- driver's seat belt not fastened
- reverse gear engaged (for example, for parking manoeuvres)
- for versions with automatic climate control, if a suitable thermal comfort

level has not yet been reached or to enable MAX-DEF function

during the first period of use, to initialise the system.

In the above cases, a message appears on the display and (for versions/markets where provided) the warning light or the symbol  flash on the instrument panel.

ENGINE RESTARTING CONDITIONS

For reasons of comfort, limiting harmful emissions and safety purposes, the power unit can restart automatically without any action by the driver if certain conditions are met, including:

- conventional battery and auxiliary lithium battery (1.0 FireFly Hybrid version) not sufficiently charged
- reduced braking system vacuum (e.g. if the brake pedal is pressed repeatedly)
- car moving (e.g. when driving on roads with a gradient)
- engine stopping by Start&Stop system for over 3 minutes
- for versions equipped with automatic climate control, to enable suitable thermal comfort or with MAX-DEF activation.

With a gear engaged, the engine can be automatically restarted only by fully depressing the clutch pedal.

The operation is indicated to the driver by a message which appears on the display and, where provided, by the warning light or by the symbol  on the instrument panel.

NOTE If the clutch is not pressed, after 3 minutes from the engine stopping, the engine can be restarted only using the ignition key.

NOTE In cases of undesired engine stops, due for example to the clutch pedal being released abruptly with a gear engaged, if the Start&Stop system is activated, the engine can be restarted by fully depressing the clutch pedal or by placing the gear lever in neutral.

SAFETY FUNCTIONS

When the engine is stopped by the Start&Stop system, if the driver releases his/her seat belt and opens the driver's or passenger's door, the engine can be restarted only using the ignition key.

This condition is signalled to the driver both with an acoustic signal and with a message on the display (on some versions it is signalled with the  warning light flashing on the instrument panel).

"ENERGY SAVING" FUNCTION



(for versions/markets, where provided)

If, following the automatic engine restarting, the driver does not carry out any action on the car for over 3 minutes, the system stops the engine definitely, to prevent fuel consumption. In these cases, the engine can be restarted only using the ignition key.

Note In any case, it is possible to keep the engine running by deactivating the Start&Stop system.

NOTE In any case, it is possible to keep the engine running by deactivating the Start&Stop system.

IRREGULAR OPERATION

In the case of malfunctions the Start&Stop system is disabled. The driver is informed of the fault by the  warning light switching on (on some versions together with a message on the display) along with the  symbol (for versions/markets, where provided) on the display.

In this case, contact a Fiat Dealership.

CAR INACTIVITY

 138)

When the car is inactive (or when replacing the conventional battery), special care must be taken while disconnecting the electrical system from the battery.

The procedure must be performed by disconnecting the connector (A) fig. 131 (pressing the button (B)) from the sensor (C) monitoring the battery charge conditions, on the negative pole (D) of the battery.

This sensor should never be disconnected from the battery pole except if the battery is replaced.

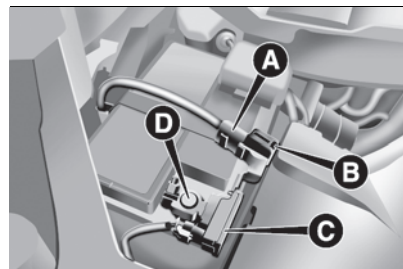

131

F0S0374

WARNING After turning the key to STOP and closing the driver's door, wait at least one minute before disconnecting the conventional battery and then reconnecting the electrical supply to the battery.

EMERGENCY STARTING

When jump starting with a conventional battery, never connect the negative lead – fig. 132 of the conventional battery to negative battery terminal



(A), but only to an earth point on the engine/gearbox assembly.

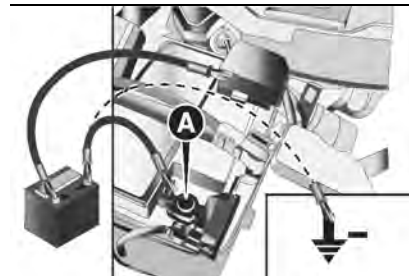

132

F0S0375

WARNINGS

 139) 140) 141)

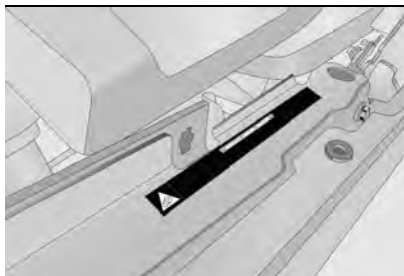

133

F0S0276



WARNING

138) If the battery needs to be replaced, always contact a Fiat Dealership. Replace the battery with a new one of the same EFB (Enhanced Flooded Battery) type and specifications.

139) Before opening the bonnet, make sure that the vehicle is switched off and the key is in the STOP position. Please follow the instructions on the decal near the front crossmember. It is advisable to extract the key when there are other people in the car. The car should always be left after the key has been removed or turned to the STOP position. When refuelling, make sure that the car is switched off with the key in the STOP position.

140) We recommend that you remove the key from the ignition if other people remain in the vehicle. Exit from the car only after having removed the ignition key or having rotated it to the STOP position. During refuelling, make sure that the engine is off and that the ignition key is in the STOP position.

141) For cars with Dualogic transmission, if the engine is automatically stopped on a slope, the engine should be restarted by moving the gear lever to + or - without releasing the brake pedal. For cars with Dualogic transmission, where the Hill Holder function is present, in the case of car stopped on a slope, the engine does not cut off automatically, so as to make the Hill Holder function - which is active only when the engine is running - available.



IMPORTANT

48) If climate comfort is to be favoured, the Start&Stop system can be deactivated, for a continuous operation of the climate control system.

SPEED LIMITER

(for versions/markets, where provided)
This device allows the speed of the car to be limited to values which can be set by the driver.

The maximum speed can be set both with car stationary and in motion. The minimum speed that can be set is 30 km/h.

When the device is active, the car speed depends on the pressure at the accelerator pedal, until the programmed speed limit is reached (see "Speed limit programming" paragraph).

ACTIVATING THE DEVICE

To activate the device, turn ring (C) fig. 134 to position .

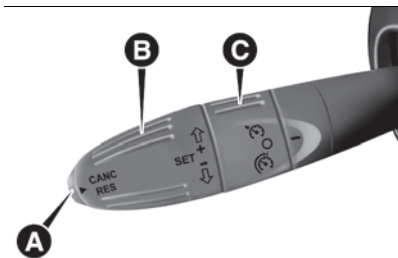

134

F0S0624

When the device is enabled, it is indicated by the  symbol being shown on the display along with the last speed set (fig. 135, fig. 136).

Versions with multifunction display:



135

F0S0626

Versions with colour display:



136

F0S0626

SPEED LIMIT PROGRAMMING

Turn on the speed limiter by turning the ring (C) to the  position. The speed limit can be programmed without necessarily activating the device.

To store a speed value higher than that displayed

Turn the ring (B) fig. 134 upwards (SET + position). On releasing the ring (B) the speed increments by 1 km/h. Holding it in the SET + position, the speed continuously increments in steps of 5 km/h.

To store a speed value lower than that displayed

Turn the ring (B) downwards (SET- position). On releasing the ring (B) the speed decrements by 1 km/h. Holding it in the SET - position, the speed continuously decrements in steps of 5 km/h.

DEVICE ACTIVATION/DEACTIVATION

Activating the device

- press and release button (A) (CANC/RES) fig. 134 or,
- if the car speed is in the range 30 to 130 km/h, turn the ring (B) upwards or downwards.

The function is activated with the current speed set as the speed limit. Device activation is indicated by the symbol  being shown on the display along with the last speed limit set.

Deactivating the device

Press button (A) (CANC/RES) fig. 134.

Device deactivation is indicated by the set being replaced by the word CANC.

Reactivating the device

- press and release button (A) (CANC/RES) fig. 134 or,
- if the car speed is in the range 30 to 130 km/h, turn the ring (B) upwards or downwards.

EXCEEDING THE PROGRAMMED SPEED

By fully depressing the accelerator pedal, the programmed speed can be exceeded even with the device active (e.g. in the event of overtaking).

The device is disabled until the speed drops below the set limit, after which it reactivates automatically.

NOTE It is advisable to decelerate to a speed at least 5 km/h below that programmed limit. Otherwise, the acoustic warning may activate to warn that the speed limit has been exceeded.

FLASHING OF PROGRAMMED SPEED

The programmed speed flashes in the following cases:

- when the accelerator pedal has been fully depressed and the car has exceeded the programmed speed;



- ❑ activating the system after setting a limit below the effective vehicle speed (with acoustic warning);
- ❑ when the device cannot reduce the vehicle speed due to the gradient of the road (with acoustic warning);
- ❑ in the event of sharp acceleration.

DEACTIVATING THE DEVICE

To activate the device, turn ring (C) fig. 134 to position 0.

Automatic off of the device

The device deactivates automatically in the event of fault in the system. In this case, contact a Fiat Dealership.

AUTOMATIC RESET OF THE PROGRAMMED SPEED

With the Speed Limiter enabled, pressing button (A) (CANC/RES) fig. 134 at a higher speed than the set value, the engine torque will be reduced as required to reach that value, if it was not reached within 20 seconds from pressing the button.

ELECTRONIC CRUISE CONTROL



(for versions/markets, where provided)
This is an electronically controlled driving assistance device that allows the desired car speed to be maintained, without having to press the accelerator pedal.

This device can be used at a speed above 30 km/h on long stretches of dry, straight roads with few variations (e.g. motorways).

It is therefore not recommended to use this device on extra-urban roads with traffic. Do not use the device in town.

ACTIVATING THE DEVICE

 142) 143) 144)

To activate the device, turn ring (C) fig. 137 to position . The  symbol comes on to indicate that the device has been activated (versions with multifunction display: fig. 138, versions with colour display: fig. 139).

The device cannot be engaged in 1st or reverse gear: it is advisable to engage it in 3rd gear or higher.

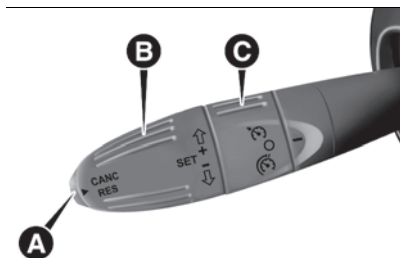

I 37

F0S0624



I 38

F0S0628



I 39

F0S0627

WARNING It is dangerous to leave the device on when it is not used. There is a risk of inadvertently activating it and losing control of the car due to unexpected excessive speed.

SETTING THE DESIRED SPEED

Proceed as follows:

□ activate the device by turning the ring (C) fig. 137 downwards.

□ when the vehicle has reached the desired speed, turn the ring (B) upwards (or downwards) and release it to activate the device. When the accelerator is released, the vehicle will automatically maintain the selected speed.

If needed (e.g. when overtaking), you can increase speed simply by pressing the accelerator; when you release the pedal, the car goes back to the speed stored previously.

When travelling downhill with the device active, the vehicle speed may slightly exceed the set one.

WARNING Before turning the ring (B) upwards or downwards, the vehicle must travel at a constant speed on level ground.

INCREASING SPEED

Once the electronic Cruise Control has been activated, the speed can be increased by turning the ring (B) upwards.

DECREASING SPEED

To decrease the speed with the device activated, turn the ring (B) downwards.

RECALLING THE SPEED

For versions with Dualogic transmission operating in D mode (Drive - automatic), press and release button (A) (CANC/RES) fig. 137 to recall the previously set speed.

For versions with manual gearbox or Dualogic transmission in sequential mode, before recalling the previously set speed you should accelerate until getting close to it, then press and release button (A) (CANC/RES).

DEACTIVATING THE DEVICE

Lightly pressing the brake pedal or pressing button (A) (CANC/RES) deactivates the electronic Cruise Control without deleting the stored speed.

Changing gear deactivates the Cruise Control.

DEACTIVATING THE DEVICE

The electronic Cruise Control is disabled by turning the ring (C) fig. 137 to the 0 position or putting the ignition device at STOP.



WARNING

142) While driving with the device active, never move the gear lever to neutral.

143) In case of a malfunction or failure of the device, contact a Fiat Dealership.

144) The electronic Cruise Control can be dangerous if the system cannot keep a constant speed. In specific conditions speed may be excessive, resulting in the risk of losing control of the vehicle and causing accidents. Do not use the device in heavy traffic or on winding, icy, snowy or slippery roads.



PARKING SENSORS

(for versions/markets, where provided)

 145)

 49) 50)

SENSORS

Parking sensors are located in the rear bumper fig. 140 and detect and inform the driver, through an intermittent acoustic signal, of the presence of obstacles at the rear of the car.



140

F0S0578

ACTIVATION

The sensors are automatically activated when reverse gear is engaged. The acoustic warning becomes more frequent as the obstacle behind the car gets closer.

ACOUSTIC WARNING

When reverse gear is engaged and there is an obstacle behind the car an acoustic warning is activated and the warning varies as the distance of the

obstacle from the bumper varies. The frequency of the acoustic warning:

- increases as the distance between car and obstacle decreases
- becomes continuous when the distance between the car and the obstacle is less than 30 cm and stops immediately if the distance increases
- is constant if the distance between the car and the obstacle is unchanged.

If this situation concerns the side sensors, the signal will stop after approximately 3 seconds to avoid, for example, indications in the event of manoeuvres along a wall.

If several obstacles are detected by the sensors, only the nearest one is considered.

INDICATIONS ON DISPLAY

(versions with colour display)

When the sensors are activated, the screen in fig. 141 appears on the display.



141

F0S0558

The system indicates a detected obstacle by displaying an arc according to the distance of the obstacle and its position in relation to the car.



When the system detects an obstacle, an arc appears in one or more positions according to the distance of the obstacle from the car. If an object is detected in the rear left, central or right zone, the display shows a flashing arc in the corresponding zone and a sound is emitted.

As the car approaches the object, the display shows one or more flashing arcs that approach the car, and the sound becomes more frequent until it becomes continuous.

The colour on the display depends on the distance from and position of the obstacle. The car is close to the obstacle when a blinking red arc appears on the display (to the right, in the centre or to the left) and a

continuous sound is emitted. If there are several obstacles, the closest one is indicated.

FAULT INDICATIONS

Any parking sensor faults will be indicated when reverse is engaged by the  warning light or the  icon (for versions with colour display) on the instrument panel.

OPERATION WITH A TRAILER

(except the 1.0 FireFly Hybrid version)
The operation of the sensors is automatically deactivated when the trailer electric cable plug is inserted in the tow hook socket of the car. The sensors are automatically reactivated when the trailer's cable plug is removed.

GENERAL WARNINGS

When parking, take the utmost care over obstacles that may be above or under the sensor. Under certain circumstances, objects close to the vehicle are not detected by the system and could therefore cause damage to the car or be damaged themselves. The following conditions may influence the performance of the parking assistance system:

the presence of ice, snow, mud or multiple layers of paint on the surface

of the sensor may reduce its sensitivity and the system performance;

mechanical interference (e.g.

washing the car, rain, strong wind, hail) may cause the sensor to detect a non-existent obstacle ("echo interference");

the presence of ultrasonic systems (e.g. pneumatic brake systems of trucks or pneumatic drills) near the vehicle could alter the signals sent to the sensor;

the variation in sensor position, caused by variation in ride (due to suspension or shock absorber wear), changing tyres, overloaded car, or tuning that lowers the car, for example, may affect parking sensor system performance;

the presence of a tow hook without trailer interferes with the correct operation of the parking sensors. If a fixed tow hook is installed, the sensors cannot be used. If the customer installs a removable tow hook, it should be disconnected from the crossmember whenever the trailer is not attached to prevent the activation of the sensors.

the presence of adhesives on the sensors. Therefore, take care not to place stickers on the sensors.



WARNING

145) *Parking and other dangerous manoeuvres are, however, always the driver's responsibility. While carrying out these manoeuvres, always make sure that no people (especially children) or animals are in the area concerned. The parking sensors are an aid for the driver, but the driver must never allow their attention to lapse during potentially dangerous manoeuvres, even those executed at low speeds.*



IMPORTANT

49) *For correct operation of the system, sensors must always be clean from mud, dirt, snow or ice. Be careful not to scratch or damage the sensors while cleaning them. Avoid using dry, rough or hard cloths. The sensors must be washed using clean water, with the addition of vehicle shampoo if necessary. When using special washing equipment such as high pressure jets or steam cleaning, clean the sensors very quickly keeping the jet more than 10 cm away.*

50) *Have interventions on the bumper in the area of the sensors carried out only by a Fiat Dealership. Interventions on the bumper that are not carried out properly may compromise the operation of the parking sensors.*



DRIVING TIPS

SAVING FUEL

Below are some suggestions which may help you save fuel and thus lower the amount of harmful emissions released into the atmosphere.

Car maintenance

Checks and maintenance should be carried out in accordance with the "Service Schedule" (see the "Maintenance and care" section).

Tyres

Check the tyre pressures at least once every four weeks: if the pressure is too low, consumption levels increase as resistance to rolling is higher.

Unnecessary loads

Do not travel with an overloaded luggage compartment. The weight of the vehicle and its arrangement greatly affect fuel consumption and stability.

Roof rack/ski rack

Remove the roof rack or the ski rack from the roof when they are not used. These accessories lower aerodynamic penetration and adversely affect consumption levels. When transporting particularly large objects, use a trailer if possible.

Electric devices

Use electrical devices only for the amount of time needed. The heated rear window, windscreen wipers and heater fan require a considerable amount of energy; increasing the current uptake increases fuel consumption (by up to +25% in an urban cycle).

Climate control system

Using the climate control system will increase consumption: use standard ventilation when the temperature outside permits.

Devices for aerodynamic control

The use of non-certified devices for aerodynamic control may adversely affect air drag and consumption levels.

DRIVING STYLE

Start

Do not warm up the engine at low or high revs when the car is stationary; this causes the engine to warm up more slowly, thereby increasing fuel consumption and emissions. It is therefore advisable to move off immediately, slowly, avoiding high speeds: in this way the engine will warm up more quickly.

Unnecessary actions

Avoid rewinding when starting at traffic lights or before stopping the engine.

The latter action, as well as double-declutching, is unnecessary and causes increased fuel consumption and pollution.

Gear selection

Use a high gear when traffic and road conditions allow it. Using a low gear for faster acceleration will increase fuel consumption. In the same way, improper use of a high gear increases consumption, emissions and engine wear.

Top speed

Fuel consumption considerably increases as speed increases. Maintain a constant speed, avoiding unnecessary braking and acceleration, which cost in terms of both fuel consumption and emissions.

Acceleration

Accelerating violently severely affects consumption and emissions: acceleration should be gradual and should not exceed the maximum torque.

CONDITIONS OF USE

Cold starting

Short journeys and frequent cold starts do not allow the engine to reach optimum operating temperature. Consequently, both consumption (from

+15 to +30% on the urban cycle) and emissions will increase.

Traffic and road conditions

High fuel consumption is caused by heavy traffic, for instance when travelling in a queue with frequent use of low gears or in cities with many traffic lights. Winding mountain roads and rough road surfaces also adversely affect consumption.

Stops in traffic

During prolonged hold-ups (e.g. level crossings) switch off the engine.

TRANSPORTING PASSENGERS

Warnings

WARNING It is extremely dangerous to leave children in a parked car when the temperature outside is very high. The heat inside the passenger compartment may have serious, or even fatal, consequences.

WARNING Never travel in the internal load compartment. In the event of an accident, anyone inside the boot would be at greater risk of serious or even fatal injury.

WARNING Ensure that all the occupants of the car wear their seat belts correctly and that any children are

positioned correctly on the dedicated child restraint systems.

TRANSPORTING ANIMALS

Comply with the regulations on transportation of animals of the country you are driving in.

EXHAUST GAS

Exhaust emissions are very dangerous, and may be lethal.

They contain carbon monoxide, a colourless, odourless gas which can cause fainting and poisoning if inhaled.

To avoid inhaling carbon monoxide, take the following measures:

- ❑ do not keep the engine running in closed spaces;
- ❑ if, for some reason (e.g. transporting bulky loads), it is necessary to drive with the liftgate open, close all the windows and run the climate control fan at maximum speed. **DO NOT** activate air recirculation mode;
- ❑ should it be necessary to stay on board the stationary car with engine running, adjust the ventilation/heating system and operate the fan in such a way that outside air enter the passenger compartment. Activate the maximum fan speed.

Adequate maintenance of the exhaust system represents the best protection

against leaks of carbon monoxide into the passenger compartment.

Should an unusual noise from the exhaust system or the presence of exhaust gas in the passenger compartment be identified, or if the underbody or rear part of the car is damaged, have the entire exhaust system and adjoining bodywork areas checked to identify any components which are broken, damaged, worn or have moved from their correct fitting position. For these operations, contact a Fiat Dealership.

Open welding or loose connections may permit exhaust gas to enter the passenger compartment.

Check the exhaust system each time the car is raised for lubrication or oil change operations. Replace the components where necessary. For these operations, contact a Fiat Dealership.



REFUELLING THE VEHICLE

 146) 147) 148)

Before refuelling, check you are using the correct type of fuel. Furthermore, turn off the engine before refuelling.

PETROL VERSIONS

Only use unleaded petrol with a number of octanes (R.O.N.) not lower than 95 (EN228 specification).

WARNING An inefficient catalytic converter leads to harmful exhaust emissions, thus contributing to air pollution.

WARNING Never introduce leaded petrol to the tank, even in small amounts in an emergency, as this would damage the catalytic converter beyond repair.

REFUELLING CAPACITY

To ensure that you fill the tank completely, top up twice after the first click of the fuel supply gun. Further top-ups could cause faults in the fuel feeding system.

FUEL TANK CAP

The cap (B) fig. 142 is fitted with a loss-prevention device that secures it to the flap (A) so that it cannot be lost.



142

F0S0678

Refuelling procedure

To unscrew the cap (B) you must first open the flap (A). The sealing may cause a slight pressure increase in the tank. A little breathing off, while slackening the cap is absolutely normal.

When refuelling, fasten the cap to the device inside the flap as in fig. 142.

LPG VERSIONS

WARNING Only use LPG for motor vehicles.

The gas filler is located next to the petrol filler cap. It has a check valve inserted in the filler body itself.

To access the filler, open the access flap (A) fig. 143 and undo the cap (B).

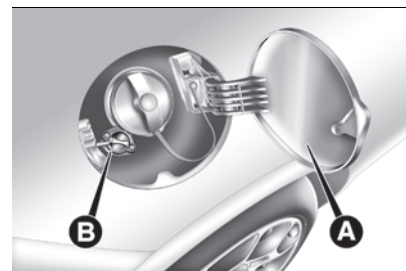

143

F0S0538

Observe the following precautions during the refuelling operation:

- stop the engine;
- apply the handbrake;
- turn the ignition key to STOP;
- do not smoke;
- hand the special adapter over to the qualified LPG refuelling personnel.

WARNING Before refuelling with LPG, the qualified personnel must make sure that the adapter is correctly screwed onto the filler.

WARNING Depending on the country, there are various types of adapters for the refuelling pump. The adapter (C) fig. 144 that comes with the car in a special case is specifically designed for the country in which the car is sold. If you are in a different country, find out what type of adapter is used there.

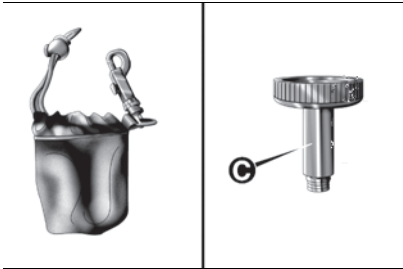

144

F0S0539

WARNING Look after the LPG adapter carefully so that it does not get damaged.

WARNING Only use LPG for motor vehicles.

WARNING Only use the adapter supplied with the vehicle as it is equipped with a dedicated fuel pre-filter.

Fuel - Vehicle compatibility identification Graphic symbol for consumer information in accordance with EN16942

The symbols shown below facilitated recognizing the correct fuel type to be used on your car. Before proceeding

with refueling, check the symbols inside the fuel filler flap (where provided) and compare them with the symbols shown on the fuel pump (where provided).

Symbols for petrol powered cars

E5: Unleaded petrol containing up to 2.7% (m/m) oxygen and with maximum 5.0% (V/V) ethanol compliant with **EN228.**

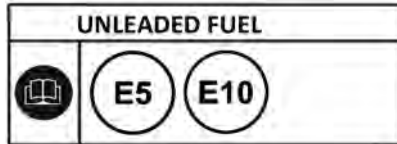

145

F0S0666

E10: Unleaded petrol containing up to 3.7% (m/m) oxygen and with maximum 10.0% (V/V) ethanol compliant with **EN228.**

Symbols for petrol/LPG bi-fuel cars

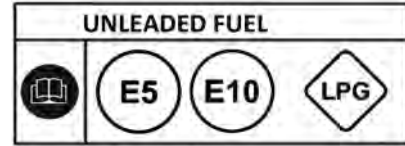

146

F0S0687

E5: Unleaded petrol containing up to 2.7% (m/m) oxygen and with maximum 5.0% (V/V) ethanol compliant with **EN228.**

E10: Unleaded petrol containing up to 3.7% (m/m) oxygen and with maximum 10.0% (V/V) ethanol compliant with **EN228.**

LPG: Automotive LPG compliant with **EN589.**



WARNING

146) Do not approach naked flames or lit cigarettes to the fuel tank filler: fire risk. Keep your face away from the fuel filler to prevent breathing in harmful vapours.

147) Do not use a mobile phone near the refuelling pump: risk of fire.

148) During normal service the catalyst reaches high temperatures; therefore do not park the car over inflammable materials



(grass, dry leaves, pine needles, etc.): fire hazard.

TOWING TRAILERS

(except the 1.0 FireFly Hybrid version)

 149) 150)

WARNINGS

For towing caravans or trailers the car must be fitted with an approved tow hook and an adequate electrical system.

Installation should be carried out by specialised technicians who will issue the required papers for travelling on roads.

Install any specific and/or additional rear-view mirrors as specified by the Highway Code.

Remember that, when towing a trailer, steep hills are harder to climb, braking distances increase and overtaking takes longer depending on the overall weight of the trailer. Engage a low gear when driving downhill, rather than constantly using the brake.

The weight the trailer exerts on the car tow hook reduces the loading capacity of the car by the same amount. To make sure that the maximum towable weight is not exceeded (given in the vehicle registration document) account

should be taken of the fully laden trailer, including accessories and luggage. Respect the speed limits specific to each country for cars towing trailers. In any case, the top speed must not exceed 100 km/h.

WARNING The engine must be running when using auxiliary loads other than external lights.

WARNING To install a tow hook contact a Fiat Dealership.



WARNING

149) *If the car has an ABS system, it will not control the braking system of the trailer. Particular caution is required on slippery roads.*

150) *Never modify the braking system of the vehicle to control the trailer brake. The trailer braking system must be fully independent of the vehicle's hydraulic system.*

IN AN EMERGENCY

Have a flat tyre or a burnt-out bulb?

At times, a problem such as these may interfere with your driving experience.

The pages on emergencies can help you to deal with critical situations independently and calmly.

In an emergency, we recommend that you call the phone number found in the Warranty Booklet.

It is also possible to call the national or international universal freephone number to search for the nearest Dealership.

HAZARD WARNING LIGHTS	144
REPLACING A BULB	144
FUSE REPLACEMENT	152
CHANGING A WHEEL	154
Fix&Go KIT	158
JUMP STARTING	161
FUEL CUT-OFF SYSTEM	163
TOWING THE VEHICLE	163



HAZARD WARNING LIGHTS

Press button (A) fig. 147 to switch the hazard lights on/off regardless of the position of the ignition key. With the device on, warning lights \leftarrow and \rightarrow light up in the instrument panel. Press the button (A) again to switch the lights off.



147

F0S0614

WARNING The use of hazard warning lights is governed by the highway code of the country you are driving in: comply with legal requirements.

Emergency braking

In the event of an emergency braking, the hazard warning lights switch on automatically together with warning lights \leftarrow and \rightarrow on the instrument panel. The lights switch off automatically when emergency braking ceases.

REPLACING A BULB

 151) 152) 153) 154)

 51) 52)

GENERAL INSTRUCTIONS

- Before replacing a bulb check the contacts for oxidation;
- burnt bulbs must be replaced by others of the same type and power;
- always check the headlight beam direction after changing a bulb;
- when a light is not working, check that the corresponding fuse is intact before replacing a bulb. For the location of fuses, refer to the paragraph "Replacing fuses" in this chapter.

WARNING When the weather is cold or damp or after heavy rain or washing, the surface of headlights or rear lights may steam up and/or form drops of condensation on the inside. This is a natural phenomenon due to the difference in temperature and humidity between the inside and the outside of the glass which does not indicate a fault and does not compromise the normal operation of lighting devices. The mist disappears quickly when the lights are turned on, starting from the centre of the diffuser, extending progressively towards the edges

BULB TYPES

The car is equipped with the following bulbs:

All-glass bulb: (type A) these are pressure fitted - pull to remove.

Bayonet bulb: (type B) to remove them press the bulb and turn it anticlockwise.

Cylindrical bulbs: (type C) release them from their contacts to remove.

Halogen bulbs: (type D) release the fastening clip from its housing to remove the bulb.

Halogen bulbs: (type E) release the fastening clip from its housing to remove the bulb.

Xenon gas discharge bulbs: (type F) for replacement, contact a Fiat Dealership.

A



B



C

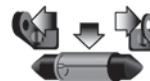

D



E



F



Light bulbs

Use	Type	Power	Ref. Figure
Main beam headlights	H7	55W	D
Dipped beam headlights	H7	55W	D
Dipped headlights with gas discharge bulbs (Xenon) (for versions/markets, where provided)	D1S	35W	F
Front side lights / daytime running lights	LED/21W	LED/21W	A
Front direction indicators	WY21W / PY24W	21W/24W	B
Front direction indicators (with xenon gas discharge bulbs)	PY24W	24W	B
Side direction indicators	W5W	5W	A
Rear direction indicators	PY21W	21W	B
Tail/brake light	P21 / 5W	10W	B
Reverse gear	W16W	21W	B
Rear fog light	W16W	21W	B
Ceiling light	C5W	5W	C
Boot light	W5W	5W	A
Number plate light	C5W	5W	C
Fog lights	H1/H11 (*)	55W	E
Third brake lights	W5W	5W	A

(*) For versions/markets where provided

REPLACING AN EXTERNAL BULB FRONT LIGHT CLUSTERS

The front light clusters contain side/tail lights, dipped headlights, main beam headlights and direction indicator bulbs.

Front direction indicators

(POP versions only)

To replace the bulb, proceed as follows:

- operating from the engine compartment remove the rubber cap (A) fig. 148;

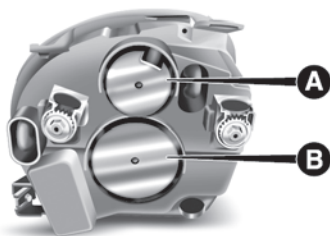

148

F0S0050

- turn the bulb holder (A) fig. 149 anticlockwise and extract it;
- remove the pressure-fitted bulb and replace it;
- refit the bulb holder (A) by turning it clockwise and making sure that it locks correctly;

- refit the rubber cap.



149

F0S0052

Front direction indicators

(Excluding POP versions)

To replace the bulb, proceed as follows:

- operating in the engine compartment, remove the plastic cap (A) fig. 150 by turning it anticlockwise;

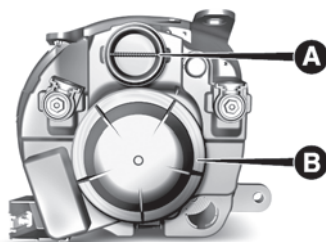

150

F0S0591

- turn the bulb holder anticlockwise and remove it;

- replace the bulb-bulb holder assembly;
- refit the bulb holder in its housing (A) fig. 151 by turning it clockwise and locking it correctly;

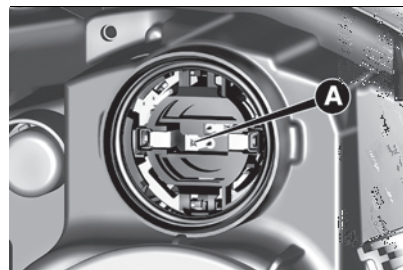

151

F0S0608

- refit the protection cap in its housing and turn clockwise.

Side direction indicators

WARNING The intervention must be carried out taking all precautions necessary to avoid damaging the bodywork (please use a sufficiently rigid and appropriately thick plastic card).

To replace the bulb, proceed as follows:

- lever the lens off, by initially applying force from the front towards the back (1-fig. 152);
- then lever in the opposite direction, by applying force from the back part (2-fig. 152) and remove unit;



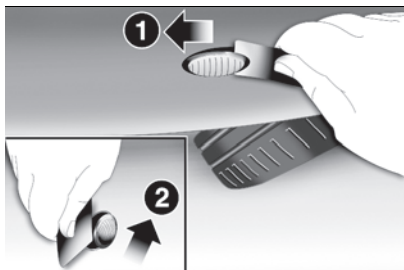

152

F0S0355

- turn the bulb holder anticlockwise, extract the press-fitted bulb and replace it;
- refit the bulb holder in the lens, then position unit, ensuring that the fastening clip clicks into place.



Dipped beam headlights

(POP versions only)

To replace the bulb, proceed as follows:

- operating from the engine compartment remove the protective rubber cap (B) fig. 148;
- press the fastener (A) fig. 153 and remove the bulb holder;



153

F0S0063

- remove the pressure-fitted bulb and replace it;
- refit the bulb holder locking it correctly;
- refit the rubber cap.

Dipped beam headlights

(Excluding POP versions)

To replace the bulb, proceed as follows:

- operating in the engine compartment, remove the protective plastic cap (B) fig. 150 by turning it anticlockwise;
- disconnect connector (A) fig. 154 and release the bulb holder catch;
- extract the bulb and replace it;
- refit the bulb in its housing and reconnect the connector;

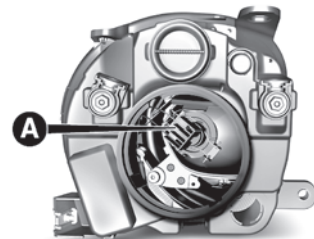

154

F0S0593

- refit the protection cap in its housing and turn clockwise.

Dipped beam headlights with gas discharge bulbs (Xenon)

(for versions/markets, where provided)



For replacement, contact a Fiat Dealership.

Main beam headlights

To replace the bulb, proceed as follows:

- steer the wheel fully inwards, undo the screws (A) fig. 155 and move the inner wheel arch plastic cover (B) aside to access the bulb;

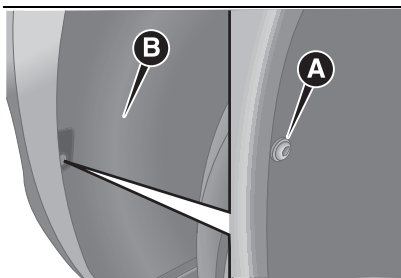

155

F0S0747

- remove the rubber cap on the bulb holder;
- free the bulb holder from the side clips (A) fig. 156 and remove it;

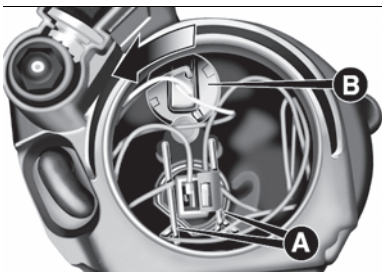

156

F0S0054

- fit the new bulb, making the outline of the metallic part coincide with the grooves on the reflector, then reattach the bulb holding clips;
- refit the rubber cap;
- refit the inner cover on the wheel arch and tighten the screws.

Sidelights/daytime lights

To replace the bulb, proceed as follows:

- steer the wheel fully inwards, undo the screws (A) fig. 155 and move the inner wheel arch plastic cover (B) aside to access the bulb;
- remove the rubber cap on the bulb holder;
- rotate the bulb holder (B) fig. 156 anticlockwise and extract it;
- extract the bulb and replace it;
- refit the bulb holder (B) by turning it clockwise and making sure that it locks correctly;
- refit the rubber cap;
- refit the inner cover on the wheel arch and tighten the screws.

Fog lights

To replace a fog light, contact a Fiat Dealership.

REAR LIGHT CLUSTERS

These contain the bulbs for the side lights, brake lights and direction indicators. The reversing lights and rear fog lights are located instead in the rear bumper.

The bulbs are arranged as follows fig. 157:

- C:** side lights/brake lights;
- D:** direction indicators.

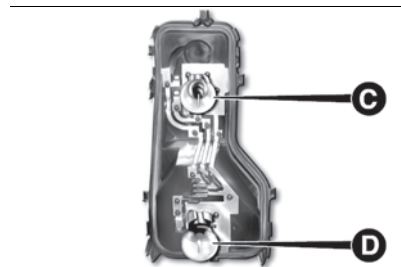

157

F0S0580

To replace the bulb proceed as follows:

- open the tailgate;
- unscrew the two fastening screws (A) fig. 158 and extract the light cluster axially without rotating it;

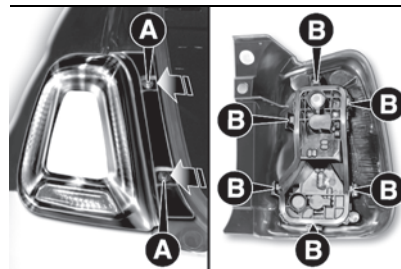

158

F0S0579

- remove the bulb holder from its housing releasing it from the locking tabs (B) fig. 158;
- extract the bulbs by pushing them slightly and turning them anticlockwise.



REVERSING LIGHT/REAR FOG LIGHT

To replace the bulb, proceed as follows:

- access the bulb holder through the underside of the rear bumper fig. 159;

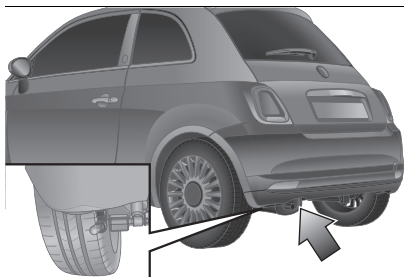

159

F0S0674

- disconnect the electrical connector (A) fig. 160;
- rotate the bulb holder (B) fig. 160 anticlockwise and extract it;
- release the bulb and replace it;

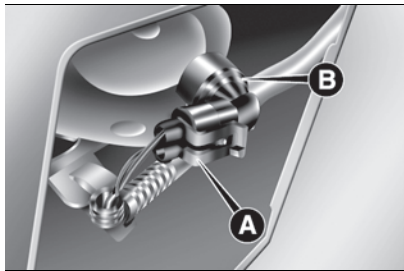

160

F0S0582

- reinsert the bulb/bulb holder unit (B) by turning it clockwise;
- reconnect the electrical connector (A).

THIRD BRAKE LIGHTS

To replace the bulb proceed as follows:

- remove the two guard caps and unscrew the two fastening screws (A) fig. 161;

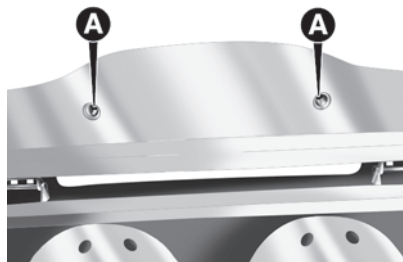

161

F0S0058

- remove the assembly;
- disconnect the electrical connector (B) fig. 162;
- press the retaining device (C) fig. 162 and open the bulb holder;

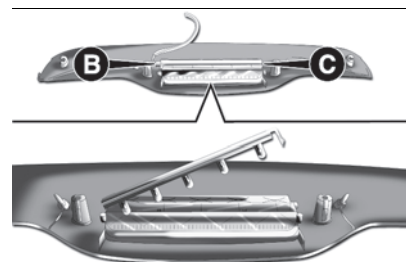

162

F0S0059

- remove the press-fitted bulb to be replaced and replace it;
- close the bulb holder making sure the retaining device is correctly locked;
- screw in the two fastening screws and reinstall the guard caps.

NUMBER PLATE LIGHTS

To replace the bulbs, proceed as follows:

- operate in the point shown by the arrow fig. 163 and remove the lens;

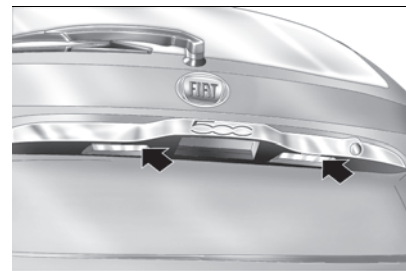

163

F0S0139

- change the bulb, releasing it from the side contacts;
- fit the new bulb and make sure that it is correctly clamped between the contacts;
- then refit the lens.

REPLACING INTERIOR BULBS

Inside ceiling light

To replace the bulb, proceed as follows:

- using the screwdriver provided, extract the ceiling light (A) fig. 164 working in the point shown by the arrow;

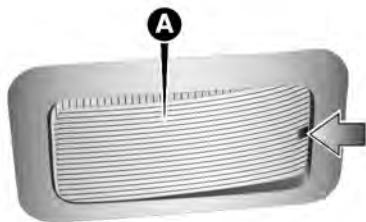

164

F0S0060

- open cover (B) fig. 165 as shown and then change bulb (C) it from the side contacts;

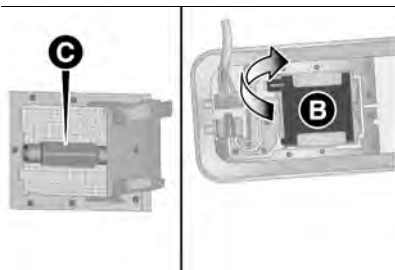

165

F0S0356

- insert the new bulb and make sure that it is correctly clamped between the contacts;
- close the cover (B) then refit the lens (A).

Boot courtesy light

(for versions/markets, where provided)

To replace the bulb, proceed as follows:

- open the boot;
- using the screwdriver provided, extract the ceiling light (A) fig. 166 working in the point shown by the arrow;

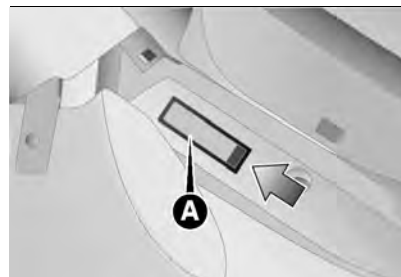

166

F0S0063

- open the protection (B) fig. 167 replace the snap-fitted bulb (C);

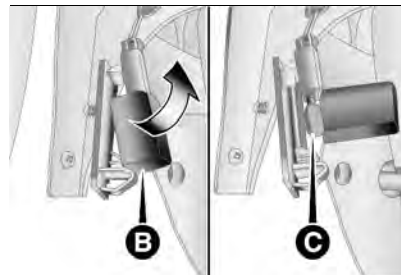

167

F0S0064

- close the cover (B) on the lens;
- then refit the ceiling light by inserting it correctly in its housing, on one side and then pressing on the other side until it clicks into place.



WARNING

151) Modifications or repairs to the electric system that are not carried out properly or do not take the system technical specifications into account can cause malfunctions leading to the risk of fire.

152) Halogen bulbs contain pressurised gas, in the case of breakage they may burst causing glass fragments to be projected outwards.

153) Only replace the light bulbs when the engine is off and in a position that does not interfere with traffic and lets you safely replace them (see the description in the "Replacement" paragraph). Also ensure that the engine is cold, to prevent the risk of burns.

154) Before replacing the bulb, wait for the exhaust ducts to cool down: **DANGER OF SCALDING!**

155) Due to the high power supply voltage, gas discharge bulbs (Xenon) should only be replaced by specialised technicians: danger of death! Contact a Fiat Dealership.

IMPORTANT

51) Halogen bulbs must be handled holding the metallic part only. Touching the transparent part of the bulb with your fingers may reduce the intensity of the emitted light and even reduce the lifespan of the bulb. In the event of accidental contact, wipe the bulb with a cloth moistened with alcohol and let the bulb dry.

52) Where possible, it is advisable to have bulbs changed at a Fiat Dealership. The correct operation and direction of the external lights are absolutely essential for the safety of the car and of compliance with the law.

53) The intervention must be carried out taking all precautions necessary to avoid damaging the bodywork (please use a sufficiently rigid and appropriately thick plastic card).

FUSE REPLACEMENT

For fuse replacement, contact a Fiat Dealership.

 **156) 157) 158) 159) 160) 161) 162)**

GENERAL INFORMATION

Fuses protect the electrical system: they intervene (blow) in the event of a failure or improper action on the system.

Check the state of the corresponding fuse when a device does not work: the filament (A) fig. 168 should be intact. If it is not, replace the blown fuse with another with the same ampere rating (same colour).

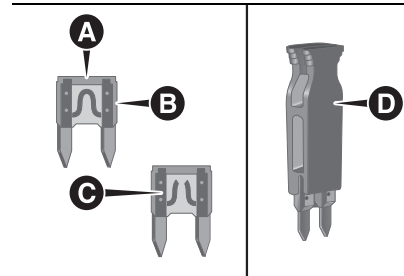

168

F0S0065

(B) = intact fuse;
 (C) = fuse with damaged filament.
 To change a fuse, use the pincers (D) attached in position (A) fig. 169 behind the press-fit cover (B) fig. 170.

Refer to the tables on the following pages to identify the protective fuse.

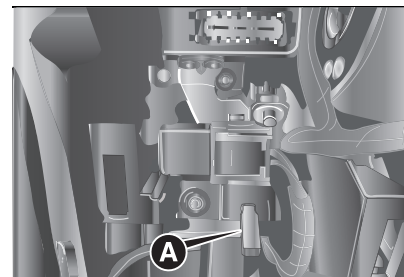

169

F0S0714

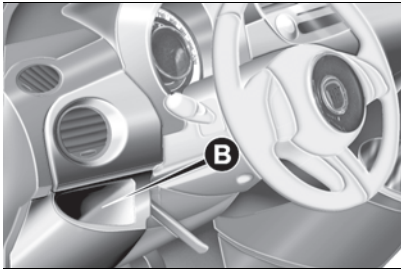

170

F0S0715

DASHBOARD FUSEBOX

To access the fuses you must remove the press-fitted cover (B) fig. 170.

The 5A fuse (B) for door mirror demisting is located in the diagnosis socket area, as shown in fig. 171.

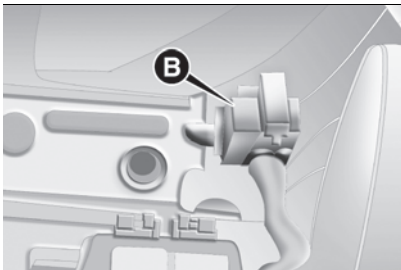

171

F0S0677

The dashboard fuse box shown is located in the lower area next to the pedal board.

ENGINE COMPARTMENT FUSEBOX



The fusebox is located on the right side of the engine compartment. To access the fuses, proceed as follows:

- ❑ Fully press screw (A) fig. 172;
- ❑ at the same time slowly rotate the screw anticlockwise, until resistance is encountered (do not overtighten);
- ❑ slowly release the screw;
- ❑ opening is indicated by the entire screw head coming out of its seat;
- ❑ remove cover (B), sliding it upwards on the side guides, as indicated in the figure.

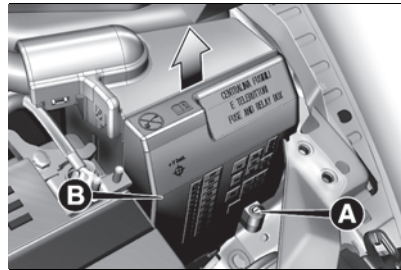

172

F0S0608

Once the fuse has been replaced, proceed as follows:

- ❑ correctly refit the cover (B) in the side guides of the casing;
- ❑ slide it down completely from the top;

- ❑ fully tighten screw (A), using the screwdriver provided;
 - ❑ at the same time slowly rotate the screw clockwise, until resistance is encountered (do not overtighten);
 - ❑ slowly release the screw;
 - ❑ closure is indicated by the securing of the entire screw head in its housing.
- The number identifying the electrical component corresponding to each fuse is shown on the control unit cover.

LPG versions

The LPG system components are protected by specific fuses. Contact a Fiat Dealership for replacement.



WARNING

- 156)** For fuse replacement, contact a Fiat Dealership.
- 157)** If the replaced fuse blows again, contact a Fiat Dealership.
- 158)** Never replace a faulty fuse with metal wires or anything else.
- 159)** Never replace a fuse with another with a higher amp rating; **RISK OF FIRE.**
- 160)** If a general fuse (MEGA-FUSE, MIDI-FUSE, MAXI-FUSE) blows contact a Fiat Dealership.
- 161)** Before replacing a fuse, make sure that the ignition key has been removed and that all the other services are switched off and/or disengaged.
- 162)** Contact Fiat Dealership if a safety system (airbags, brakes), engine system



(engine, gearbox) or steering system
general protection fuse blows.



IMPORTANT

54) If you need to wash the engine compartment, take care not to directly hit the engine compartment fusebox with the water jet.

FUSES

 163) 164)  55)



WARNING

163) Replacement of a fuse. All work may be performed only by a Fiat Dealership or a qualified repair workshop. The replacement of a fuse by a third party may cause a serious car fault.

164) Installation of electrical accessories. The car's electrical circuit is designed to function with standard or optional equipment, before installing other electrical equipment or accessories in the vehicle contact a Fiat dealership or a qualified repair workshop.



IMPORTANT

55) The manufacturer shall not be held liable for expenses resulting from car repair or anomalies resulting from the installation of accessories not provided or recommended by the manufacturer and

not installed according to specifications, in particular when the combined consumption of all additional equipment connected exceeds 10 mA.

CHANGING A WHEEL

GENERAL INSTRUCTIONS

 165) 166) 167) 168) 169) 170) 171) 172) 173)

The car may be fitted with a space-saver wheel (for versions/markets where provided).

JACK

Please note that:

- the jack weight is 1.76 kg;
- the jack requires no adjustment;
- the jack cannot be repaired and in the event of a fault it must be replaced by another genuine one;
- no tool other than its cranking device may be fitted on the jack.

MAINTENANCE

- prevent any dirt from depositing on the "worm screw"
- keep the "worm screw" lubricated
- never modify the jack.

CONDITIONS OF NON-USE

- at temperatures lower than -40°C on a sandy or muddy ground

- on uneven ground
- on steep roads
- in extreme weather conditions: thunderstorms, typhoons, hurricanes, blizzards, storms, etc.
- in direct contact with the engine or for repairs under the car
- on boats.

RAISING WITH A JACK AND REPLACING A WHEEL

To change a wheel, proceed as follows:

- stop the car in a position that is not dangerous for oncoming traffic where you can change the wheel safely. The ground must be flat and sufficiently compact;
- stop the engine, pull up the handbrake and engage the first gear or reverse. Wear the reflective safety jacket (compulsory by law) before getting out of the car;
- raise the mat on the floor of the luggage compartment;
- unscrew the locking device (B) fig. 173;
- take out the toolbox (C) fig. 173 and bring it next to the wheel to be replaced;
- take the space saver spare wheel (D) fig. 173;

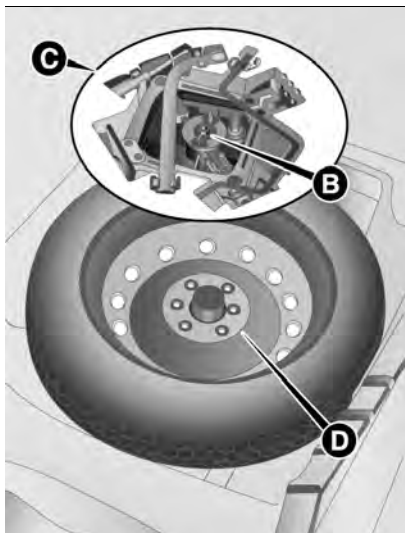

173

F0S0127

□ for vehicles with wheel cap: use the screwdriver provided, applying leverage to the dedicated opening on the outer edge;

□ for cars equipped with 15" steel wheels with aesthetic hub caps: take the extractor (A) fig. 174 from the Owner Handbook compartment;

⚠ 174)

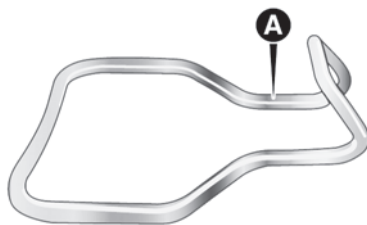

174

F0S0671

□ hold the extractor with two fingers, insert the tab between the tyre and hub cap (B) fig. 175 and pull towards yourself, perpendicularly to the wheel;

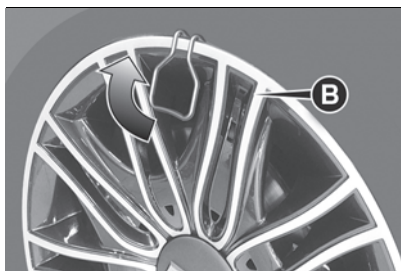

175

F0S0670

□ for cars fitted with alloy wheels: remove the press-fitted hub cap using the screwdriver provided;

□ loosen the retaining bolts for the wheel to be changed by about one turn using the spanner provided;

□ if the car is equipped with side skirts, to let the jack pass under the car, the latter must be tilted (as shown in fig. 176);

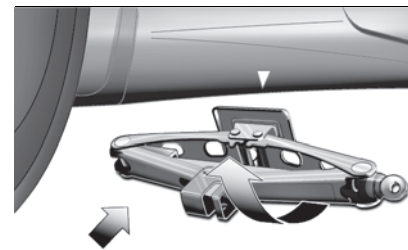

176

F0S0328

⚠ 56)

□ turn the jack handle to partially open it;

□ position the jack near the wheel to be repaired at the reference point ▽ on the side member; Lifting the rear wheel: fig. 177 Lifting the rear wheel: fig. 178 .

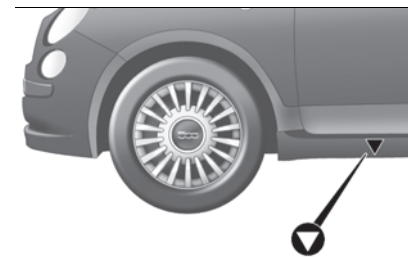

177

F0S0630



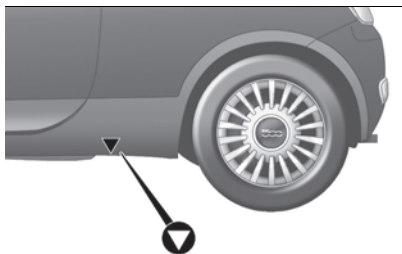

178

F0S0631

- make sure that the jack fig. 179 is positioned correctly;
- alert any bystander that the car is about to be raised; all persons should be kept away from the car and nobody must touch it until it has been lowered;

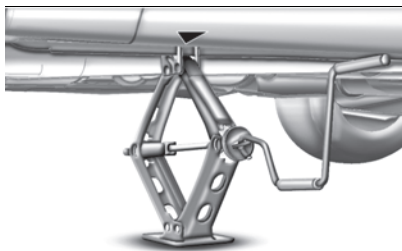

179

F0S0653

- fit the handle to operate the jack and raise the car until the wheel is a few centimetres above the ground. When turning the jack handle, make sure that it can turn freely without scraping your hand against the ground. The moving

components of the jack (screws and joints) can also cause injuries: avoid touching them. If you come into contact with lubricating grease, clean yourself thoroughly;

- loosen the bolts completely and remove the wheel to be replaced;
- make sure the contact surfaces between space-saver wheel and hub are clean so that the fastening bolts will not come loose;
- fit the space-saver spare wheel, with the pin (N) fig. 180 aligned with one of the holes (O) on the wheel;

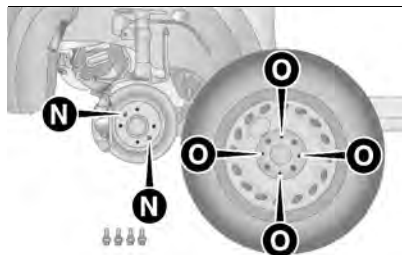

180

F0S0130

- screw in the 4 fastening bolts;
- turn the jack handle to lower the car and remove the jack;
- fasten the bolts completely, passing alternately from one bolt to the opposite one.

REFITTING THE STANDARD WHEEL



Following the procedure described previously, raise the car and remove the space-saver wheel.

Versions with steel wheels

Proceed as follows:

- make sure the contact surfaces between standard wheel and hub are clean so that the fastening bolts will not come loose;
- fit the standard wheel inserting the 4 bolts into the holes;
- using the wrench provided, tighten the fastening bolts;
- lower the car and remove the jack;
- use the wrench provided to fully tighten the bolts, passing alternately from one bolt to the opposite one;
- insert the pressure-fit cup making the suitable slot coincide with the inflation valve;
- place the inner part of the hub cap on the wheel rim;
- engage the hub cap by applying an axial force in several points as shown in fig. 181 to allow the correct coupling between hub cap and wheel.



181

F0S0632

For cars equipped with 15" steel wheels with cosmetic hub caps:



174)

- once the normal wheel has been fitted, insert the press-fit hub cap, aligning the slot with the inflation valve;
- place the inner part of the hub cap on the wheel rim;
- engage the hub cap by applying an axial force in several points as shown in fig. 182 to allow the correct coupling between hub cap and wheel.



182

F0S0669

Versions with alloy rims

Proceed as follows:

- insert the wheel on the hub and use the spanner provided to tighten the bolts;
- lower the car and remove the jack;
- use the wrench provided to fully tighten the bolts in an alternating sequence;
- reinsert the press-fitted hub cap, making sure that the reference hole on the wheel is aligned with the reference pin on the cap.

WARNING If it is not fitted correctly, the hub cap may detach when the vehicle is running.

At the end of the operation

Proceed as follows:

- arrange the space-saver wheel (D) fig. 173 in the specific compartment in the luggage compartment;
- insert the partially open jack into container (C) fig. 173 and force it slightly into its housing so that it does not vibrate while driving;
- put the tools back into their places in the container;
- stow the container complete with tools on the spare wheel and secure everything with the clamping device (B) fig. 173;

- correctly reposition the luggage compartment mat.

WARNING Do not use air chambers with Tubeless tyres. Check the inflation pressure of the tyres and the space-saver wheel regularly.



WARNING

165) *The space-saver wheel (for versions/markets where provided) is specific to your car, do not use it on other models, nor use the space-saver wheel of other models on your car. The space-saver wheel must only be used in the event of an emergency. Never use it for more than strictly necessary and never exceed 80 km/h.*

166) *On the space-saver wheel there is an orange sticker, summarising the main warnings regarding space-saver wheel usage restrictions. Never remove or cover the label. The label contains the following indications in four languages: "Warning! For temporary use only! 80 km/h max.! Replace with standard wheel as soon as possible. Never cover this indication". Never apply a wheel cap on a space-saver wheel.*

167) *If you change the type of wheel (alloy rims instead of steel rims and vice versa) you will have to change the entire set of fastening bolts with another set of suitably sized bolts.*

168) *Alert other drivers that the car is stationary in compliance with local*



regulations: hazard warning lights, warning triangle, etc. Any passengers on board should leave the car, especially if it is heavily laden. Passengers should stay away from on-coming traffic while the wheel is being changed. On hills or uneven roads, use chocks or appropriate objects to block the wheels of the vehicle.

169) The driving features of the car may change when a space-saver wheel is fitted. Avoid violent acceleration and braking, abrupt steering and fast cornering. The total life of a space-saver spare wheel is approximately 3,000 km, after which it must be replaced by another wheel of the same type. Never install a traditional tyre on a rim designed to be used as a space-saver wheel. Have the wheel repaired and refitted as soon as possible. Using two or more space-saver wheels at the same time is forbidden. Do not apply grease to the bolt threads before fitting: they could come unscrewed.

170) The jack is a tool developed and designed only for changing a wheel, if a tyre gets punctured or damaged, on the car with which it is supplied or on other cars of the same model. It must not be used, for example, to jack other vehicle models or objects. Never use it to carry out servicing or repairs under the car or to change summer/winter wheels and vice versa. Never position yourself under a jacked vehicle. Should it be necessary to work under the vehicle, contact a Fiat Dealership. Incorrectly positioning the jack may cause the vehicle to fall: use it only in the positions indicated. Do not use the jack for loads higher than the one shown on its label. Never start the engine with vehicle raised. If the vehicle is raised more

than necessary, everything can become more unstable, with the risk of the vehicle dropping violently. So lift the car just enough to access the space-saver/spare wheel.

171) Snow chains cannot be fitted to the space-saver wheel. So, if a front (drive) wheel is punctured and chains are needed, a rear wheel should be fitted to the front of the car and the space-saver wheel should be fitted to the rear. In this way, equipped with two normal drive wheels at the front, they can be fitted with snow chains, thus resolving the emergency situation.

172) Incorrectly fitting the wheel cap may cause it to fall off when the car is in motion. Never tamper with the inflation valve. Never introduce tools of any kind between rim and tyre. Check tyre and space-saver wheel pressures regularly, complying with the values given in the "Technical specifications" chapter.

173) It is extremely dangerous to attempt to change a wheel on the side of the car next to the driving lane: make sure that the car is at a sufficient distance from the road, to avoid being run over.

174) Be very careful when removing/refitting the hub cap due to the proximity of the brake disc. We recommend using heat protection gloves.



IMPORTANT

56) When turning the jack handle make sure that it can turn freely without scraping your hand against the ground. The moving components of the jack ("worm screw"

and joints) can also cause injuries: avoid touching them. If you come into contact with lubricating grease, clean yourself thoroughly.

57) Contact a Fiat Dealership as soon as possible to have the correct tightening of the wheel bolts checked.

Fix&Go KIT

(for versions/markets, where provided)
The Fix&Go quick tyre repair kit is located in the boot inside a dedicated container.

175) 176) 177)

58)

TYRE REPAIR PROCEDURE

Preliminary operations:

- Stop the car in a position that is not dangerous for oncoming traffic where you can change the wheel safely. The ground must be flat and sufficiently compact;
- stop the engine and engage the parking brake;
- engage 1st gear if the car is uphill, or reverse if the car downhill;
- steer the wheels completely;
- in the event of a steep slope, place a wedge or stone behind the wheels;
- Wear the reflective safety jacket (compulsory by law) before getting out of the car. In any case, follow the

road safety laws in force in the country where you are driving;

☐ wear the gloves.

Tyre repair:

Remove the adhesive speed label (3) fig. 183 and fig. 186 and apply it in a clearly visible position on the dashboard.

OPT1 kit

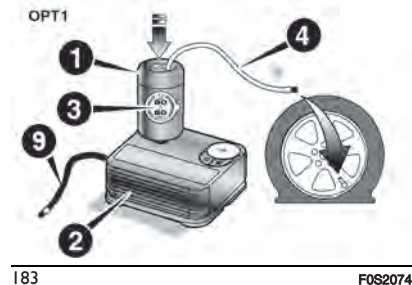

☐ remove the cap from the tyre valve and connect and screw the transparent tube of the sealant (4) fig. 183 onto the valve. If a 250 ml cartridge is present the housing of the transparent tube is provided with removable ring to facilitate extraction. Make sure that the ON/OFF button (5) fig. 184 is in the off position (button not pressed);

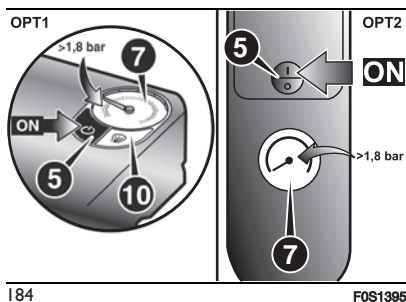

☐ plug the electrical connector of the tyre inflation kit into the 12V socket of the car and start the engine;

☐ operate the compressor by pressing the ON/OFF button (5) fig. 184. When the pressure gauge (7) indicates the prescribed pressure indicated in the "Wheels" chapter in this Owner Handbook or on the label, switch off the compressor by pressing the button again and in any case do not disconnect the hose until the sealing liquid has been blown in (about 2 minutes);

☐ If the pressure gauge (7) fig. 184 reads a pressure lower than 1.8 bar / 26 psi 15 min. after turning on the compressor, switch off the compressor, disconnect the sealant hose (4) fig. 183 from the tyre valve proceed with the procedure for restoring pressure after repair described in the following paragraph

after having disconnected the cartridge. Disconnect the cartridge (1) from the compressor, by pressing the release button (8) and lifting the cartridge (1) upwards fig. 185.

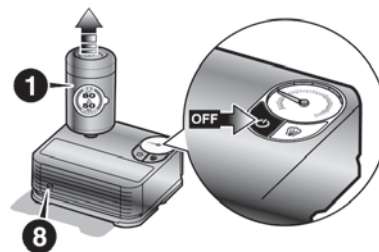

185

P2000161

OPT2 kit



186

F0S2075

Use only in the event of a puncture. Do not use to inflate tyre that is not punctured.



- ❑ remove the cap from the tyre valve and connect and screw the transparent tube of the sealant (4) fig. 186 onto the valve. Make sure that the ON/OFF button (5) fig. 184 is in the off position (button not pressed);
- ❑ plug the electrical connector of the tyre inflation kit into the 12V socket of the car and start the engine;
- ❑ operate the compressor by pressing the ON/OFF button (5) fig. 184. When the pressure gauge (7) indicates the prescribed pressure indicated in the "Wheels" chapter in this Owner Handbook or on the label, switch off the compressor by pressing the button again and in any case do not disconnect the hose until the sealing liquid has been blown in (about 2 minutes);
- ❑ If the pressure gauge (7) fig. 184 reads a pressure lower than 1.8 bar / 26 psi 15 min. after turning on the compressor, switch off the compressor, disconnect the sealant hose (4) fig. 186 from the tyre valve proceed with the procedure for restoring pressure after repair described in the following paragraph.

Procedure for restoring pressure after repair

- ❑ Move the car by approximately 10 m to allow the distribution of the sealant;

❑ secure the car following the instructions described in the "Preliminary operations" paragraph in this chapter;

❑ restore the pressure using the black inflation tube (9) fig. 183 for the **OPT1** version or the inflation tube (4) fig. 186 for the **OPT2** version until the prescribed pressure is reached. If also in this case, the pressure is lower than 1.8 bar / 26 psi 15 minutes after turning on, do not resume driving but contact a Fiat Dealership.

Only for **OPT1**: Press the air release button to adjust any tyre overpressure (10) fig. 184.

After driving for approximately 8 km / 5 miles, repeat the procedure for restoring the pressure.

For **OPT2** only: This can only be used to restore pressure after using the kit to repair a puncture (i.e. with empty sealing cartridge)



WARNING

175) The information required by the applicable regulation is indicated on the Fix&Go kit package label. Carefully read the label on the cartridge before use, avoid improper use. The kit should be used by adults and cannot be used by children.

176) IMPORTANT: Do not exceed 80 km/h. Avoid sudden acceleration or

braking. The kit provides a temporary repair, therefore the tyre must be examined and repaired by a specialist as soon as possible. Before using the kit, ensure that the tyre is not excessively damaged and that the rim is in good condition, otherwise do not use it and call roadside assistance. Do not remove foreign bodies from the tyre. Do not let the compressor turned on for more than 20 consecutive minutes - overheating hazard.
177) The compressor in the kit MAY NOT BE USED for purposes other than tyre repair.



IMPORTANT

58) The sealant fluid is effective with external temperatures from -40°C to +50°C. The sealant fluid has an expiry date and must be replaced periodically. It is possible to repair tyres with damage on the tread up to a maximum diameter of 6 mm. Show the cartridge and the label to the personnel who must handle the tyre treated with the TireKit.

JUMP STARTING

 178) 179) 180)

 59) 60) 61)

If the conventional battery is flat, jump starting can be performed using cables and the battery of another car, or using a supplementary lead battery. In all cases, the battery used must have a capability equal to or a little higher than the flat one.

Jump starting may be dangerous if carried out incorrectly: carefully follow the procedures described below.

WARNINGS

After turning the ignition key to STOP and closing the driver's door, wait at least one minute before disconnecting the conventional battery and then reconnecting the electrical supply to the battery.

Do not use an auxiliary lead battery or any other source of external supply with a voltage above 12 V: the conventional battery, the starter (for versions/markets, where provided), the alternator (for versions/markets, where provided), the hybrid system (for versions/markets, where provided) or the car's electrical system could be damaged.

Do not attempt jump starting if the conventional battery is frozen. The battery could break and explode!

JUMP STARTING

For 1.2 8V 69 HP and 0.9 TwinAir versions without Start&Stop

If the battery is flat, the engine may be started using an auxiliary battery fig. 187 with the same capacity or a little higher than the flat one.

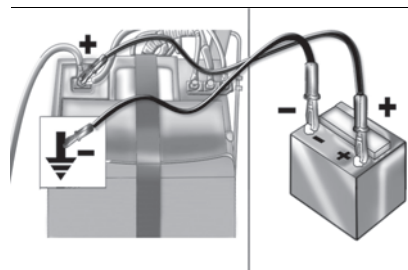

187

F0S0093

Proceed as follows to start the car:

- connect the positive terminals (+ mark near the terminal) of the two batteries using a suitable lead;
- use a second cable to connect the negative terminal (-) of the supplementary lead battery to an earth point  on the engine or gearbox of the car to be started;
- start the engine;
- when the engine has been started, remove the leads reversing the order above.

For 1.2 8V 69 HP and 0.9 TwinAir versions with Start&Stop

When jump starting, NEVER connect the negative cable (-) of the supplementary lead battery to the negative pole (-) of the car battery, but only to an earth point on the engine/gearbox assembly.

If after a few attempts the engine does not start, do not persist but contact a Fiat Dealership.

WARNING Do not directly connect the negative terminals of the two batteries: sparks could ignite explosive gas released from the battery. If the supplementary lead battery is installed on another car, prevent accidental contact between metal parts of the two cars.

For the 1.0 FireFly Hybrid version

 62) 63)

If the battery is flat, the engine may be started using another lead battery fig. 188 with the same capacity or a little higher than that of the flat one.



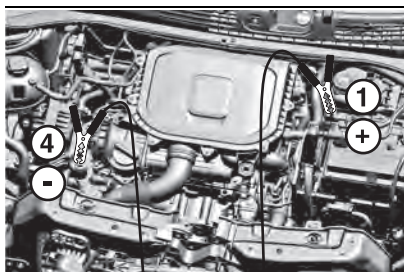

188

F0S0717

To start, proceed as follows in the numerical order shown in fig. 188:

- ❑ connect the positive terminals (+ mark near the terminal) of the two batteries using a suitable lead;
- ❑ with a second cable, connect the negative terminal (-) of the supplementary battery to an earth point on the engine or gearbox of the car to be started as in fig. 188;
- ❑ start the engine;
- ❑ when the engine has been started, remove the leads reversing the order above.

When jump starting, NEVER connect the negative cable (-) of the supplementary battery to the negative pole (-) of the car battery, but only to an earth point on the engine/gearbox assembly.

If after a few attempts the engine does not start, do not persist but contact a Fiat Dealership.

WARNING Do not directly connect the negative terminals of the two batteries: sparks could ignite explosive gas released from the battery. If the supplementary battery is installed on another car, prevent accidental contact between metal parts of the two cars.

BUMP STARTING

Never bump start the motor by pushing, towing or driving downhill. This could cause fuel to flow into the catalytic converter and damage it beyond repair.

WARNING Remember that the brake servo and electrical power steering system (for versions/markets, where provided) are not active until the engine is started. A much greater effort will therefore be required to use the brake pedal or turn the steering wheel.



WARNING

178) This starting procedure must be performed by expert personnel because incorrect actions could cause electrical discharge of considerable intensity. Furthermore, conventional battery fluid is poisonous and corrosive: avoid contact with skin and eyes. Keep naked flames and lighted cigarettes away from the battery and do not cause sparks.

179) Remove any metal objects (e.g. rings, watches, bracelets), that might cause an accidental electrical contact and cause serious injury.

180) Do not attempt to recharge a frozen conventional battery: first it must be thawed, otherwise there is a risk of explosion. If freezing has occurred, the battery should be checked by skilled personnel to make sure that the internal elements are not damaged and that the body is not cracked, with the risk of leaking poisonous and corrosive acid.



IMPORTANT

59) Never use a fast battery charger to start the engine as this could damage the electronic systems, particularly the engine ignition and fuel supply control units.

60) Do not connect the cable to the negative terminal (-) of the flat battery. The following spark could lead to battery explosion and cause serious harm. Only use the specific earth point; do not use any other exposed metallic part.

61) Never bump start the engine by pushing, towing or coasting downhill. This could cause fuel to flow into the catalytic converter and damage it beyond repair.

62) Do not start the car by connecting the supplementary battery to the auxiliary lithium battery for the hybrid system under the front left seat, but connect it to the battery in the engine compartment only.

63) Do not connect the cable to the negative terminal (-) of the flat conventional battery. The following spark could lead to battery explosion and cause serious harm. Only use the specific earth point; do not use any other exposed metallic part.

FUEL CUT-OFF SYSTEM



181)

This intervenes in the case of an impact causing:

- the interruption of the fuel supply with the engine consequently cutting out
 - the automatic unlocking of the doors
 - turning on the lights inside the car.
- The intervention of the system is indicated by a message shown on the display.
- automatic disconnection of the auxiliary battery from the electrical system (for the 1.0 FireFly Hybrid version).

WARNING Carefully check the car for fuel leaks, for instance in the engine compartment, under the car or near the tank area. After a collision, turn the ignition key to STOP position to prevent the conventional battery from draining.

To restore the correct operation of the car, proceed as follows:

- turn the ignition key to the MAR position
- activate the right direction indicator
- deactivate the right direction indicator
- activate the left direction indicator
- deactivate the left direction indicator
- activate the right direction indicator
- deactivate the right direction indicator
- activate the left direction indicator
- deactivate the left direction indicator
- turn the ignition key to the STOP position
- turn the ignition key to the MAR-ON position.

LPG versions: in the event of an impact, petrol supply is immediately cut-off, the LPG safety valves are closed and the injection is interrupted, switching off the engine.

For the 1.0 FireFly Hybrid version

WARNING The auxiliary lithium battery can only be reconnected to the electrical system by a Fiat Dealership.



WARNING

181) If, after an impact, you smell fuel or notice leaks from the fuel system, do not reactivate the system to avoid the risk of fire.

TOWING THE VEHICLE



182) 183) 184) 185)

The tow hook, which is supplied with the vehicle, is housed in the tool box, under the carpet in the luggage compartment.

ATTACHING THE TOW HOOK

Front

Proceed as follows:

- release the cap (A) fig. 189;
- take the tow hook (B) fig. 189 from its housing in the tool box;
- fully tighten it on the threaded pin.

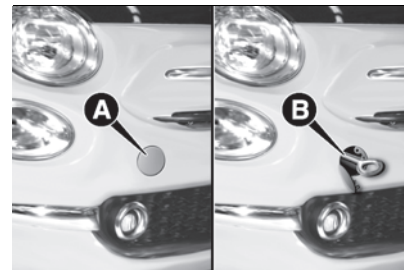

189

FOS0583



Rear

- ❑ release the cap (A) fig. 190;
- ❑ take the tow hook (B) fig. 190 from its housing in the tool box;
- ❑ fully tighten it on the threaded pin.

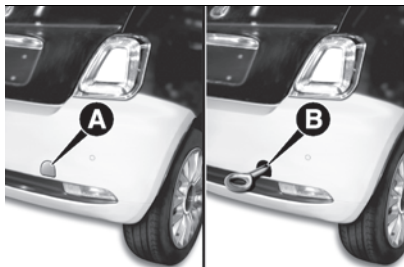

190

F0S0584

VERSIONS WITH DUALOGIC TRANSMISSION

Make sure that the transmission is in neutral (N) (checking that the car moves when pushed) and proceed in the same way as for towing a normal car with a manual transmission.

If the gearbox cannot be put in neutral, do not tow the vehicle and contact a Fiat Dealership.

**WARNING**

182) Before towing, turn the ignition key to MAR-ON and then to STOP without removing it. The steering column will automatically lock when the key is

removed and the wheels cannot be steered.

183) Before tightening the ring clean the threaded housing thoroughly. Make sure that the ring is fully fastened in the housing before towing the car.

184) The (front/rear) tow ring must be used exclusively for roadside assistance operations. You are allowed to tow the vehicle for short distances using an appropriate device in accordance with the highway code (a rigid bar), to move the vehicle on the road in readiness for towing or transporting via a breakdown vehicle. The tow hook **MUST NOT** be used to tow cars off the road or where there are obstacles, nor for towing using cables or other non-rigid devices. In compliance with the above conditions, towing must take place with the two cars (one towing, the other towed) aligned as much as possible along the same centre line.

185) Whilst towing, remember that the assistance of the brake servo and the electric power steering is not available, therefore greater force needs to be exerted on the brake pedal and more effort is required on the steering wheel. Do not use flexible cables when towing and avoid jerky movements. While towing, make sure that the trailer hitch does not damage any components it is touching. When towing the vehicle, you must comply with all specific traffic regulations and adopt an appropriate driving behaviour. Do not start the engine while towing the car.

MAINTENANCE AND CARE

Proper maintenance allows car performance to be maintained over time, operating costs to be contained, and safety system performance to be safeguarded.

This chapter explains how.

SCHEDULED SERVICING	166
CHECKING LEVELS	172
CONVENTIONAL BATTERY	176
AUXILIARY LITHIUM BATTERY	179
BRAKES	179
REPLACING THE WINDSCREEN/REAR WINDOW WIPER BLADES	180
RAISING THE CAR	181
WHEELS AND TYRES.....	181
CAR INACTIVITY	182
BODYWORK	183
INTERIOR	186



SCHEDULED SERVICING

Correct servicing is crucial for guaranteeing a long life for the vehicle under the best conditions. For this reason, Fiat has planned a series of checks and services at fixed distance and/or time intervals, as described in the Service Schedule.

To keep the efficiency of the car in tip-top condition, in the following Scheduled Service plan pages a few additional checks are listed that should be carried out more frequently with respect to the normal scheduled service deadline. Scheduled Servicing is offered by Fiat Dealerships according to fixed time or kilometres/miles intervals. If, during each operation, in addition to the ones scheduled, the need arises for further replacements or repairs, these may be carried out with the owner's explicit agreement only. If your car is used frequently for towing, the interval between one scheduled servicing operation and the next should be reduced.

IMPORTANT NOTES

The scheduled service deadlines are set out by the Manufacturer. Failure to have them carried out may invalidate the warranty.

We advise sharing any doubts regarding the car's proper operation with your Fiat Dealership, before waiting for the next coupon redemption.

SERVICE SCHEDULE

WARNING Once you have carried out the last intervention in the table, continue with the scheduled servicing, maintaining the frequency indicated in the plan by marking each operation with a dot or dedicated note. Warning: simply restarting the maintenance from the start of the plan may cause the allowed interval to be exceeded for some operations!

Thousands of miles	9	18	27	36	45	54	63	72	81	90
Thousands of kilometres	15	30	45	60	75	90	105	120	135	150
Years	1	2	3	4	5	6	7	8	9	10
Check tyre condition/wear and adjust pressure, if necessary; check the expiry date of the "Fix&Go" repair kit (for versions/markets, where provided)	•	•	•	•	•	•	•	•	•	•
Check operation of lighting system (headlights, direction indicators, hazard warning lights, boot, passenger compartment, glove compartment, instrument panel warning lights, etc.)	•	•	•	•	•	•	•	•	•	•
Check and, if necessary, top up fluid levels (1)	•	•	•	•	•	•	•	•	•	•
Check exhaust emissions/smokiness	•	•	•	•	•	•	•	•	•	•
Use the diagnosis socket to check fuel/engine control systems operation, emissions and engine oil decay (the latter for versions/markets, where provided)	•	•	•	•	•	•	•	•	•	•
Visually inspect the condition of: bodywork, underbody protection, pipes and hoses (exhaust - fuel - brakes), rubber parts (boots, sleeves, bushes, etc.)	•		•		•		•		•	
Check windscreen/rear window wiper blade position/wear (for markets/versions, where provided)	•		•		•		•		•	
Check operation of the windscreen wiper/washer system and adjust nozzles, if necessary	•		•		•		•		•	



Thousands of miles	9	18	27	36	45	54	63	72	81	90
Thousands of kilometres	15	30	45	60	75	90	105	120	135	150
Years	1	2	3	4	5	6	7	8	9	10
Check cleanliness of hood and boot locks, cleanliness and lubrication of linkage	•		•		•		•		•	
Check soft top operation while closing and opening; check of seals and lubrication of canvas sliding side guide (only cabrio versions)	•		•		•		•		•	
Check handbrake lever travel and adjust, if necessary	•		•		•		•		•	
Visually inspect condition and wear of front/rear disc brake pads (for versions/markets, where provided) and operation of pad wear indicator	•	•	•	•	•	•	•	•	•	•
Visually inspect condition and wear of the rear drum brake lining	•	•	•	•	•	•	•	•	•	•
Check the auxiliary drive belt tension, and replace if necessary (for 1.0 FireFly Hybrid version and dusty roads only) (9)								•		
Visually inspect condition of various drive belt(s) (0.9 TwinAir and 1.2 8V versions)(5)				•						
Visually inspect condition of various drive belts (1.0 FireFly Hybrid version)	•	•	•	•	•	•	•	•	•	•
Inspect and if necessary adjust tensioning of accessory drive belt(s) (for versions without automatic tensioner only)		•								•
Visually inspect conditions of toothed timing drive belt (0.9 TwinAir versions excluded) (5)				•						
Check and, if necessary, adjust tappet clearance (1.2 8V petrol versions)				•				•		
Check and, if necessary, adjust tappet clearance (LPG versions)		•		•		•		•		•

Thousands of miles	9	18	27	36	45	54	63	72	81	90
Thousands of kilometres	15	30	45	60	75	90	105	120	135	150
Years	1	2	3	4	5	6	7	8	9	10
Check and, if necessary, top up Dualogic transmission electro-hydraulic control oil level (2)		•		•		•		•		•
Visually inspect condition of: LPG pipes and connectors, LPG tank fixing (LPG versions only)		•		•		•		•		•
Check fuel system operation and parameters using the diagnosis socket (LPG versions only)		•		•		•		•		•
Change engine oil and replace oil filter (0.9 TwinAir version) (3) (●)	○	•	○	•	○	•	○	•	○	•
Change engine oil and oil filter (1.0 FireFly Hybrid version)	•	•	•	•	•	•	•	•	•	•
Change engine oil and oil filter (1.2 8V 69 HP / 1.2 8V 69 HP LPG versions) (8) (●)	•	•	•	•	•	•	•	•	•	•
Spark plug replacement(4)		•		•		•		•		•
Replace accessory drive belt/s	(5)									
Replace toothed timing drive belt (1.2 8V versions)	(5)									
Replace air cleaner cartridge (6)		•		•		•		•		•
Change the brake fluid	(7)									
Replace filter inside the pressure regulator (LPG versions only)						•				
Replace paper filter (LPG in gaseous state) (LPG versions only)		•		•		•		•		•



Thousands of miles	9	18	27	36	45	54	63	72	81	90
Thousands of kilometres	15	30	45	60	75	90	105	120	135	150
Years	1	2	3	4	5	6	7	8	9	10
Replace passenger compartment cleaner (6) (O) (●)	o	●	o	●	o	●	o	●	o	●

(1) Topping up must be carried out with the fluids indicated in this Owner Handbook and only after checking that the system is undamaged.

(2) Check to be carried out every year for cars on the road in countries with particularly severe climates (cold countries).

(3) If the car is used mainly on urban routes or the annual distance travelled is less than 10,000 km, the engine oil and engine oil filter must be changed every year.

(4) For the 0.9 TwinAir versions, the following are essential to ensure correct operation: only use spark plugs of the same make and type which are specially certified for these engines (see the information in the "Engine" chapter of the "Technical specifications" section); strictly comply with the spark plug replacement frequency given in the service schedule; for spark plug replacement, it is advisable to contact a Fiat Dealership.

(5) The maximum mileage is 120,000 km / 72,000 mi (for 0.9 TwinAir and 1.2 8V versions) or 150,000 km / 90,000 mi (for the 1.0 FireFly version). The belt must be replaced every 6 years, regardless of distance travelled. In the case of demanding use of the car (dusty areas, especially severe weather conditions, very low or very high temperatures for extended periods, urban driving, long periods of idling), the maximum mileage is 60,000 km / 36,000 mi (for 0.9 TwinAir and 1.2 8V versions) or 75,000 km / 45,000 mi (for the 1.0 FireFly version). The belt must be replaced every 4 years regardless of the mileage.

(6) If the vehicle is used in dusty areas, this filter should be replaced every 15,000 km / 9,000 mi

(7) The brake fluid replacement has to be done every two years, regardless of the mileage.

(8) If the vehicle is mainly used in towns and cities and does not exceed the mileage shown on the scheduled servicing plan, change the engine oil and filter every year.

(9) The inspection, and if necessary the replacement, must be performed according to mileage and regardless of the elapsed time.

(O) Recommended operations

(●) Mandatory operations

PERIODIC CHECKS

Every 1,000 km or before long journeys, check and, if necessary, top up:

- engine coolant level;
- brake fluid level;
- windscreen washer fluid level;
- tyre inflation pressure and condition;
- operation of lighting system (headlights, direction indicators, hazard warning lights, etc.);
- operation of screen washer/wiper system and positioning/wear of windscreen/rear window wiper blades. Every 3,000 km check and top up if required: engine oil level.
- You are advised to use PETRONAS LUBRICANTS products, which have been designed and produced specifically for Fiat cars (see table "Capacities" in the "Technical specifications" section).

DEMANDING USE OF THE CAR

If the car is mainly used in one of the following particularly harsh conditions:

- towing a trailer or caravan;
- dusty roads;
- short, repeated journeys (less than 7-8 km) at sub-zero outside temperatures;
- engine often idling or driving long distances at low speeds or long periods of inactivity;

perform the following inspections more frequently than shown on the Service Schedule:

- check front disc brake pad condition and wear;
- check cleanliness of bonnet and boot locks, cleanliness and lubrication of linkage;
- visually inspect conditions of: engine, gearbox, transmission, pipes and hoses (exhaust/fuel system/brakes) and rubber elements (gaiters/sleeves/bushes, etc.);
- check battery charge and battery fluid level (electrolyte);
- visually inspect conditions of the accessory drive belts;
- check and, if necessary, change engine oil and replace oil filter;
- check and, if necessary, replace cabin air filter;
- check and, if necessary, replace air cleaner.



CHECKING LEVELS

186) 187) 64) 65)

0.9 TwinAir 85 HP version

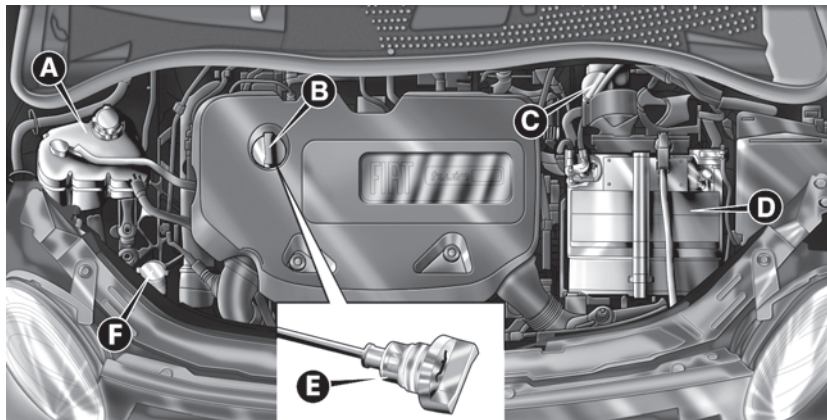

191

F0S0395

A. Engine coolant B. Engine oil cap/filler C. Brake fluid D. Conventional lead battery E. Engine oil level dipstick F. Windscreen washer fluid

1.2 8V versions

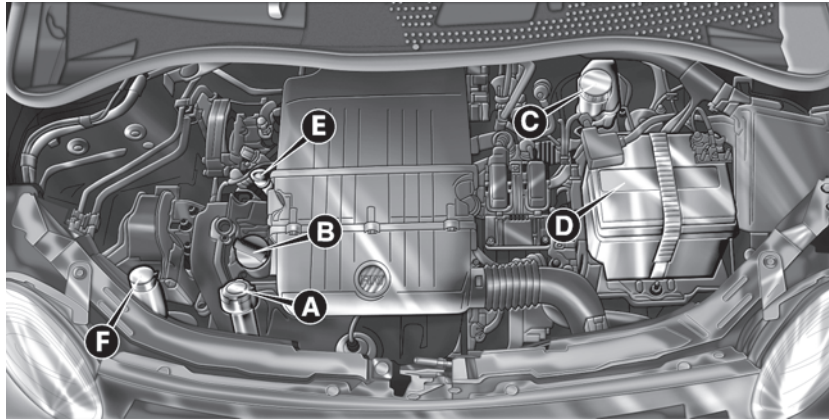

192

F0S0396

A. Engine coolant B. Engine oil cap/filler C. Brake fluid D. Conventional lead battery E. Engine oil level dipstick F. Windscreen washer fluid



1.0 FireFly Hybrid versions

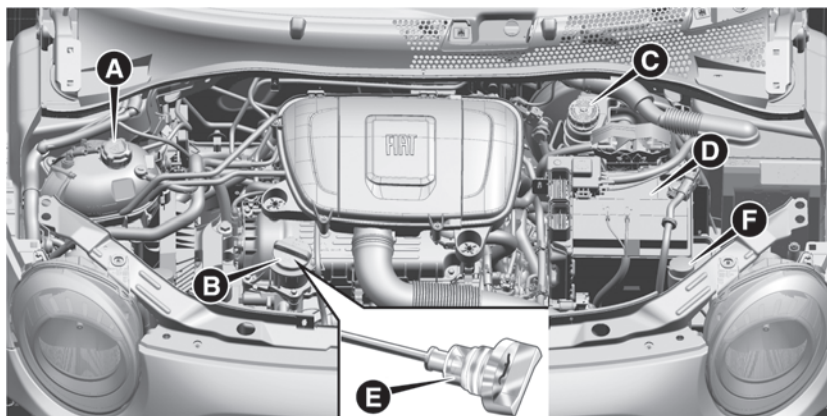

193

F0S0676

A. Engine coolant B. Engine oil cap/filler C. Brake fluid D. Conventional lead battery E. Engine oil level dipstick F. Windscreen washer fluid



WARNING

186) *Never smoke while working in the engine compartment: gas and inflammable vapours may be present, with the risk of fire.*

187) *Be very careful when working in the engine compartment when the engine is hot: you may get burned. Remember that the fan may start up if the engine is hot: this could injure you. Scarves, ties and other loose clothing might be pulled by moving parts.*



IMPORTANT

64) *Be careful not to confuse the various types of fluids while topping up: they are not compatible with one another! Topping up with an unsuitable fluid could severely damage your vehicle.*

65) *The use of products with different specifications than those indicated below could cause damage to the engine not covered by the warranty.*

ENGINE OIL

Check the oil level a few minutes (about 5) after the engine has stopped, with the vehicle parked on level ground.

NOTE The dipstick is integrated in the engine oil cap on 0.9 TwinAir and 1.0 FireFly Hybrid versions.

For 1.2 8V versions: pull out the engine oil dipstick (B), clean it with a cloth that does not leave any trace and reinsert it.

For 0.9 TwinAir and 1.0 FireFly Hybrid versions: engine oil dipstick (B) is integral with the cap (A). Unscrew the cap, clean the dipstick with a lint-free cloth, reinsert the dipstick and screw the cap back on.

Extract the engine oil dipstick again and check that the level is between the MIN and MAX marks on the dipstick.

If the level of the oil is close to or even below the MIN mark, add oil through the filler fitting (A) until the MAX mark is reached.

The range between the MIN and MAX marks corresponds to about 1 litre of oil.

The oil level must never exceed the MAX mark.

NOTE For 1.0 FireFly Hybrid versions we recommend topping up the engine oil with the help of a funnel.

Engine oil consumption

The maximum engine oil consumption is usually 400 grams every 1000 km. When the car is new, the engine needs to be run in; therefore the engine oil consumption can only be considered stabilised after the first 5000 - 6000 km.

WARNING The oil consumption depends on driving style and the conditions under which the car is used.

WARNING After adding or changing the oil, let the engine turn over for a few seconds and wait a few minutes after turning it off before you check the level.



ENGINE COOLING SYSTEM FLUID

The coolant level must be checked when the engine is cold and must range between the MIN and MAX marks on the reservoir.

If the level is too low, undo reservoir cap (C) (see previous pages) and add the fluid described in the chapter "Technical Specifications".



WINDSCREEN/REAR WINDOW WASHER FLUID

Check fluid level through the reservoir. If the liquid is too low, lift reservoir cap (D) (see previous pages) and add the fluid described in the section "Technical specifications". After topping up, close cap (D), making sure it is correctly locked.



BRAKE FLUID

Check that the fluid is at the maximum level (the fluid level in the reservoir must not exceed the MAX mark).

If the fluid level in the reservoir is too low, undo reservoir cap (E) (see the previous pages) and add the fluid described in the "Technical Specifications" chapter.

NOTE Carefully clean the cap of the reservoir (E) and the surrounding surface. Take great care to ensure that impurities do not enter the reservoir when the cap is opened. Always use a funnel with a built-in filter with a mesh of 0.12 mm or less.

WARNING Brake fluid is hygroscopic (i.e. it absorbs moisture). For this reason, if the car is mainly used in areas with a high degree of atmospheric humidity, the fluid must be replaced at more frequent



intervals than specified on the "Service Schedule".



190) 191)



68)

DUALOGIC TRANSMISSION HYDRAULIC ACTIVATION SYSTEM FLUID



4)

The fluid level should only be checked at a Fiat Dealership.



WARNING

188) *The cooling system is pressurised. If necessary, only replace the plug with another original or the operation of the system may be adversely affected. Do not remove the reservoir plug when the engine is hot: you risk scalding yourself.*

189) *Do not travel with the windscreen washer fluid reservoir empty: the windscreen washer is essential for improving visibility. Some commercial windscreen washer additives are flammable. The engine compartment contains hot components which may set it on fire.*

190) *Brake fluid is poisonous and highly corrosive. In the event of accidental contact, immediately wash the affected parts with water and mild soap. Then rinse thoroughly. Call a doctor immediately if swallowed.*

191) *The symbol , on the brake fluid container indicates if a brake fluid is synthetic or mineral-based. Use of mineral type fluids will damage the special rubber seals of the braking system beyond repair.*



IMPORTANT

66) *Do not add oil with specifications other than those of the oil already existing in the engine.*

67) *PARAFLU ^{UP} antifreeze is used in the engine cooling system. Use the same fluid as in the cooling system when topping up. PARAFLU ^{UP} fluid cannot be mixed with any other type of fluid. If this occurs, do not start the engine and contact your Fiat Dealership immediately.*

68) *Prevent brake fluid, which is highly corrosive, from coming into contact with painted parts. Should it happen, immediately wash with water.*



IMPORTANT

3) *Used engine oil and oil filters contain substances which are harmful to the environment. To change the oil and filters, we advise you to contact a Fiat Dealership.*

4) *Used transmission fluid contains substances that are harmful to the environment. It is advisable to have the oil changed by a Fiat Dealership where it will be disposed of respecting the environment and according to legal requirements.*

CONVENTIONAL BATTERY

The conventional lead-acid battery of the car is of the low-maintenance type: no electrolyte top-ups with distilled water are needed in standard conditions of use.

INSPECTING THE CHARGE AND THE ELECTROLYTE LEVEL

The operations must be carried out as described in this Owner Handbook only by specialised technicians. Topping must be carried out by specialised personnel at a Fiat Dealership.



192) 193)

REPLACING THE CONVENTIONAL BATTERY

If required, replace the conventional battery with a original spare part with the same specifications.

If a battery with different specifications is fitted, the service intervals given in the "Service Schedule" will no longer be valid.

Follow the battery manufacturer's instructions for maintenance.



194) 195) 196)



69)



5)

CAR INACTIVITY

(1.2 8V 69 HP and 0.9 TwinAir versions with Start&Stop, and 1.0 FireFly Hybrid version)

When the car is inactive (or when replacing the conventional battery), special care must be taken while disconnecting the electrical system from the battery.

The procedure must be performed by disconnecting the connector (A) fig. 194 (pressing the button (B) from the sensor (C) monitoring the battery charge conditions, on the negative pole (D) of the battery. This sensor should never be disconnected from the battery pole except if the battery is replaced.

WARNING After turning the ignition key to STOP and having closed the driver's side door, wait at least one minute before disconnecting the battery and then reconnecting the electrical supply to the battery.

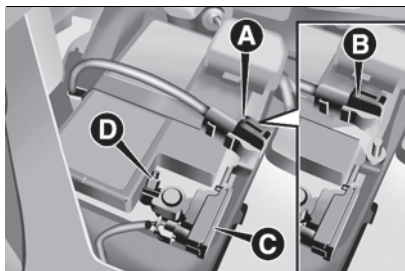

194

F0S0372

USEFUL ADVICE FOR EXTENDING THE LIFE OF THE CONVENTIONAL BATTERY

To avoid draining your battery and make it last longer, observe the following instructions:

- when you park the car, ensure that the doors, boot and bonnet are closed properly, to prevent any lights from remaining on inside the passenger's compartment;
- switch off all ceiling lights inside the car: the car is however equipped with a system which switches all internal lights off automatically;
- do not keep accessories (e.g. radio, hazard warning lights, etc.) switched on for a long time when the engine is not running;
- before performing any operation on the electrical system, disconnect

the cable from the negative battery terminal;
 completely tighten the battery terminals.

WARNING If the charge level remains under 50% for a long time, the battery is damaged by sulphation, reducing its capacity and efficiency at start-up.

The battery will also be more at risk of freezing (this can happen as early as -10°C). Refer to the "Car inactivity" chapter in the "Starting and driving" section if the car is left parked for a long time.

If after buying the car, you want to install electric accessories which require permanent electric supply (alarm, etc.) or accessories influencing the electrical supply requirements, contact a Fiat Dealership whose qualified personnel will suggest the most suitable devices from Lineaccessori MOPAR® and evaluate the overall electric absorption, checking whether the electric system in the car is able to support the required load, or if it should be integrated with a more powerful conventional battery.

Since some of these devices continue to consume electricity even when the motor is off, they gradually run down the battery.



CHARGING THE CONVENTIONAL BATTERY

 196) 197)

WARNING The conventional battery charging procedure is given for information only. You are advised to contact a Fiat Dealership to have this operation carried out.

WARNING After turning the ignition key to STOP and having closed the driver's side door, wait at least one minute before disconnecting and then reconnecting the electrical supply to the battery.

WARNING Slow charging of conventional low ampere rating battery is recommended for approximately 24 hours. Regardless of the duration of the operation it is always recommended to disconnect the conventional battery from the device as soon as charging is complete to avoid potential damage.

1.2 8V 69 HP AND 0.9 TWINAIR VERSIONS WITHOUT Start&Stop SYSTEM

(for versions/markets, where provided)

To charge, proceed as follows:

- ❑ disconnect the terminal from the negative battery pole;

- ❑ connect the charger cables to the battery terminals, observing the polarity;
- ❑ turn on the battery charger;
- ❑ when it is recharged, turn the charger off before disconnecting it from the battery;
- ❑ reconnect the terminal to the negative battery pole.

1.2 8V 69 HP AND 0.9 TWINAIR VERSIONS WITH Start&Stop SYSTEM AND 1.0 FIREFLY HYBRID VERSION

(for versions/markets, where provided)

To charge, proceed as follows:

- ❑ disconnect the connector (A) fig. 194 (pressing the button (B)) from the sensor (C) monitoring the battery charge, on the negative terminal (D) of the battery;
- ❑ connect the positive cable of the battery charger to the positive battery terminal (E) fig. 195 and the negative cable to the sensor terminal (D);

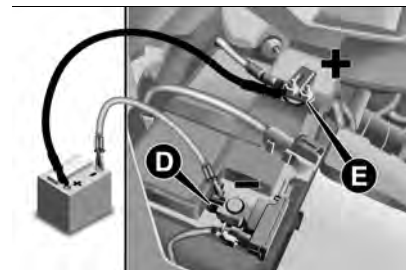

195

F0S0373

- ❑ turn on the battery charger. At the end of the charging process, switch the battery charger off;
- ❑ after having disconnected the battery charger, reconnect connector (A) to the sensor (C) as shown fig. 195.



WARNING

192) Battery fluid is poisonous and corrosive. Avoid contact with the skin and eyes. Keep open flames away from the battery and do not use objects that might create sparks: risk of explosion and fire.

193) Using the battery with low fluid will irreparably damage the battery and may cause an explosion.

194) If the car must remain unused for a long time at a very low temperature, remove the conventional battery and take it to a warm place, to avoid freezing.

195) Always wear appropriate goggles to protect your eyes when working on or near the conventional battery.

196) Do not attempt to recharge a frozen battery: first it must be thawed, otherwise there is a risk of explosion. If freezing has occurred, the battery should be checked by specialised technicians to make sure that the internal elements are not damaged and that the body is not cracked, with the risk of leaking poisonous and corrosive acid.

197) This starting procedure must be performed by expert personnel because incorrect actions could cause electrical discharge of considerable intensity. Furthermore, conventional battery fluid is poisonous and corrosive: avoid contact with skin and eyes. Keep naked flames and lighted cigarettes away from the battery and do not cause sparks.



IMPORTANT

69) Incorrect installation of electric and electronic devices may cause severe damage to your car. If after buying your car, you wish to install any accessories (anti-theft, etc.), go to a Fiat Dealership, which will suggest the most suitable devices and advise you whether a higher capacity conventional battery needs to be installed.



IMPORTANT

5) Batteries contain substances which are very harmful for the environment. For battery replacement, contact a Fiat Dealership.

AUXILIARY LITHIUM BATTERY

The auxiliary lithium battery (A) fig. 196 under the front left seat is maintenance free. Do not remove the protective cover for any reason.

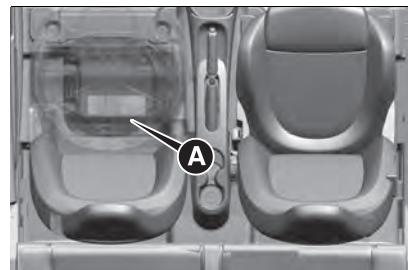

 **198)**

 **70)**



196

F0S0697

In the event of failure, the  warning light, the  symbol (for versions with colour display only) and/or the  symbol appear on the instrument panel. Contact only a Fiat Dealership to restore correct operation.



WARNING

198) When folding down the front seat, take care not rest you feet on the auxiliary battery cover under the seat to avoid

damaging it and to avoid trapping your feet between the seat and the battery.



IMPORTANT

70) Do not rest your feet on the protective cover of the auxiliary lithium battery under the front left seat to avoid damaging the cover or battery.

BRAKES

Depending on the version/market, the vehicle may be equipped with mechanical wear detectors for the brake pads: one for each wheel assembly. When the brake linings are close to wearing out, pressing the brake pedal will generate a slight squeal: this lasts for about 100 km (the mileage varies with the driving style and route). In this case, it is still possible to continue driving, with caution. However, contact a Fiat Dealership as soon as possible to have the worn brake pads changed.



REPLACING THE WINDSCREEN/REAR WINDOW WIPER BLADES

WIPER BLADES

Replace the blades if the rubber edge is deformed or worn. In any case, it is advisable to replace them approximately once a year.

A few simple precautions can reduce the possibility of damage to the blades:

- ❑ if the temperature falls below zero, make sure that ice has not frozen the rubber to the glass. Use a de-icing product to release it if required;
- ❑ remove any snow from the glass: in addition to protecting the blades, this prevents effort on the motor and overheating;
- ❑ do not operate the windscreen and rear window wipers on dry glass.

 199) 200)

RAISING THE WINDSCREEN WIPER BLADES

Lift the windscreen wiper arm and position the blade so that it forms a 90° angle with the arm.

REPLACING WIPER BLADES

Proceed as follows:

- ❑ lift up the windscreen wiper arm (A) fig. 197 and position the blade so that it forms a 90° angle with the arm;
- ❑ press the button (A) and extract from the arm (B) the blade (C);
- ❑ insert the new blade making sure it is locked into place.

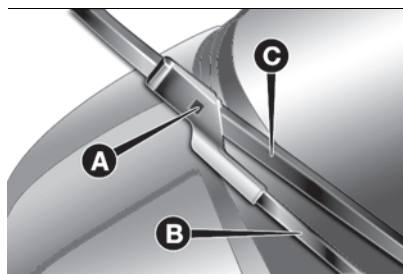

197

F0S0137

REPLACING THE REAR WINDOW WIPER BLADE

Proceed as follows:

- ❑ raise the cover (A) fig. 198 and remove the arm from the car, undoing the nut (B) that fixes it to the pivot pin;
- ❑ correctly position the new arm and tighten the nut fully;
- ❑ lower the cover.

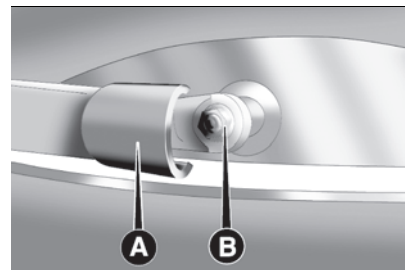

198

F0S0109

WINDSCREEN WASHER NOZZLES

If there is no jet, first check that there is fluid in the reservoir (see the "Checking fluid levels" paragraph in this chapter).

Then check that the nozzle holes are not clogged; use a needle to unblock them if necessary.

The screen washer jets can be oriented by adjusting the nozzle angles.

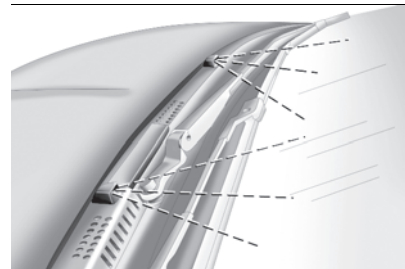

199

F0S0110

The jets should be directed at about 1/3 of the height from the top edge of the windscreen fig. 199.

WARNING In versions with a sunroof, make sure that the sunroof is closed before operating the front jets.

REAR WINDOW WASHER NOZZLE

The rear window washer jets are fixed. The nozzle holder is located above the rear window fig. 200.

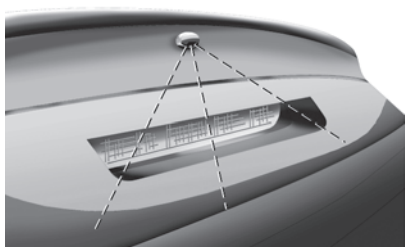

200

F0S0111



WARNING

199) Driving with worn windscreen/rear window wiper blades is a serious risk, because visibility is reduced in bad weather.

200) If the window needs to be cleaned, make sure the device is turned off or the key is on STOP.

RAISING THE CAR



71) If the car needs to be lifted, go to a Fiat Dealership which is equipped with workshop lifts and jack arms.



IMPORTANT

71) For versions equipped with side-skirts, pay particular attention when positioning the lift arms at the workshop.

WHEELS AND TYRES



201) 202) 203) 204) Check the pressure of each tyre, including the space-saver spare wheel, approximately every two weeks and before long journeys: the pressure should be checked with the tyre rested and cold.

It is normal for the pressure to increase when the car is used; for the correct tyre inflation pressure, see the "Wheels" chapter in the "Technical specifications" section.

Incorrect pressure causes abnormal tyre wear fig. 201:

A normal pressure: tread evenly worn.

B low pressure: tread particularly worn at the edges.

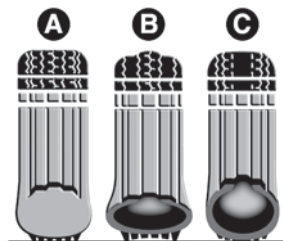

201

F0S0094

C high pressure: tread particularly worn in the centre. The tyres must be replaced when the tread is less than 1.6 mm thick. In any case, follow the laws in force in the country where you are driving.

WARNINGS

As far as possible, avoid sharp braking, screech starts and violent shocks against pavements, potholes or other hard obstacles.

Driving for long stretches over uneven roads can damage the tyres;

periodically check that the tyres have no cuts in the side wall, abnormal swelling or irregular tyre tread wear. Go to a Fiat Dealership if required;

avoid overloading the car when travelling: this may cause serious damage to the wheels and tyres;



- ❑ if a tyre is punctured, stop immediately and replace it to avoid damage to the tyre, the rim, suspension and steering system;
- ❑ tyres age even if they are not used much. Cracks in the tread and on the sidewalls are a sign of ageing. In any event, have the tyres checked by specialised technicians if they have been fitted for longer than 6 years. Also remember to check the space-saver spare wheel with particular care;
- ❑ in the case of replacement, always fit new tyres, avoiding those of unknown origin;
- ❑ if a tyre is changed, also change the inflation valve;
- ❑ to allow even wear between the front and rear tyres, it is advisable to change them over every 10–15 thousand kilometres, keeping them on the same side of the car to avoid inverting the direction of rotation;
- ❑ avoid travelling with partially or completely deflated tyres as this can compromise safety and damage the tyres beyond repair.



WARNING

201) Remember that the road holding qualities of your car also depend on correct tyre pressures.

202) If tyre pressure is too low, the tyre may overheat and be severely damaged as a result.

203) Do not switch tyres from the right-hand side of the car to the left-hand side, and vice versa.

204) Do not repaint alloy wheel rims at temperatures higher than 150°C. The mechanical features of the wheels could be compromised.

CAR INACTIVITY

If the car is to be left inactive for longer than a month, observe the following precautions:

- ❑ park the car in covered, dry and if possible well-ventilated premises and slightly open the windows;
- ❑ check that the handbrake is not engaged and engage a gear;
- ❑ disconnect the negative terminal from the conventional battery pole (for versions with Start&Stop system refer to the "Starting and driving" section of the "Start&Stop system" chapter). If the battery is not disconnected from the electrical system, check its charge every thirty days;
- ❑ for the 1.0 FireFly Hybrid version: park the car with the auxiliary lithium battery fully charged;
- ❑ clean and protect the painted parts using protective wax;

- ❑ clean and protect the shiny metal parts using special compounds available commercially;
- ❑ sprinkle talcum powder on the windscreen and rear window wiper rubber blades and lift them off the glass;
- ❑ cover the car with a fabric or perforated plastic sheet, paying particular care not to damage the painted surface by dragging any dust that may have accumulated on it. Do not use compact plastic sheets which do not allow humidity to evaporate from the surface of the car;
- ❑ inflate tyres to +0.5 bar above the standard specified pressure and check it at intervals;
- ❑ do not drain the engine cooling system.
- ❑ any time the vehicle is left inactive for two weeks or more, operate the climate control system with engine idling for at least 5 minutes, setting external air and with fan set to maximum speed. This operation will ensure appropriate lubrication for the system, thus minimising the possibility of damage to the compressor when the system is operated again.

WARNING After setting the ignition device to STOP and closing the driver's side door, wait at least one minute

before disconnecting the electrical supply from the conventional battery. When reconnecting the electrical supply to the battery, make sure that the ignition device is in the STOP position and the driver side door is closed.

For the 1.0 FireFly Hybrid version

WARNING If the auxiliary lithium battery has a low charge, this will not affect car starting.

WARNING In the event of extended inactivity, start the engine every three months and drive a section of road to charge the auxiliary lithium battery.

BODYWORK

PROTECTION AGAINST ATMOSPHERIC AGENTS

The main causes of corrosion are the following:

- ❑ atmospheric pollution
- ❑ salty air and humidity (coastal areas, or hot humid climates);
- ❑ seasonal environmental conditions.

The abrasive action of wind-borne atmospheric dust and sand, as well as mud and gravel raised by other cars is also not to be underestimated.

The manufacturer will use the best manufacturing technologies on your car to effectively protect the bodywork against corrosion.

These include:

- ❑ painting products and systems which give the car particular resistance to corrosion and abrasion;
- ❑ use of galvanised (or pretreated) sheet metal, with high resistance to corrosion;
- ❑ spraying of underbody, engine compartment, wheel arch interiors and other parts with highly protective wax products;
- ❑ spraying of plastic parts, with a protective function in the more exposed points: underdoor, inner wing, edges, etc.;

❑ use of “open” boxed sections to prevent condensation and pockets of moisture which could favour the formation of rust inside.

PRESERVING THE BODYWORK Paintwork



Paintwork does not only serve an aesthetic purpose, but also protects the underlying sheet metal.

You are advised to touch up abrasions and scratches immediately to prevent rust formation. Use only original paint products for touch-ups (see “Bodywork paint identification plate” in the “Technical Specifications” section). Normal care for paintwork consists of washing the car; how often depends on the conditions and environment where the car is used. For example, in highly polluted areas, or if the roads are spread with salt, it is advisable to wash the car more frequently.

To correctly wash the car, proceed as follows:

- ❑ remove the aerial from the roof to prevent damage to it if the car is washed in an automatic system;
- ❑ if high pressure jets or cleaners are used to wash the car, keep a distance of at least 40 cm from the bodywork to avoid damage or alteration. It should be



remembered that the build up of water can damage the car over a period of time;

- ❑ wash the bodywork using a low pressure jet of water;
- ❑ wipe a sponge with a slightly soapy solution over the bodywork, frequently rinsing the sponge;
- ❑ rinse well with water and dry with a jet of air or a chamois leather.

Dry the less visible parts with special care, such as the door frames, bonnet and the headlight frames, where water may stagnate more easily. The car should not be taken to a closed area immediately, but left outside so that residual water can evaporate.

Do not wash the car after it has been left in the sun or with the bonnet hot: this may alter the shine of the paintwork. Exterior plastic parts must be cleaned in the same way as the rest of the car.

Where possible, do not park the car under trees; the resinous substances that many species release give the paint a dull appearance and increase the possibility of triggering rusting processes.

WARNING Bird droppings must be washed off immediately and thoroughly as the acid they contain is particularly aggressive.



Versions with matt paintwork

These versions have exclusive matt paintwork which requires special care for its preservation. The instructions for good preservation follow below:

- ❑ avoid washing with rollers and/or brushes in washing stations. Then, wash the car, only by hand, using pH-neutral detergents; dry it with a wet chamois leather. Abrasive products and/or polishes should not be used for cleaning the car.
- ❑ Bird droppings must be washed off immediately and thoroughly as the acid they contain is particularly aggressive.
- ❑ Avoid (if at all possible) parking the car under trees; remove vegetable resins immediately as, when dried, it may only be possible to remove them with abrasive products and/or polishes, which is highly inadvisable as they could alter the typical opaqueness of the paint.
- ❑ Do not use pure windscreen washer fluid for cleaning the windscreen and the rear window: dilute it to at least 50% with water.
- ❑ Only use pure screen washer fluid when strictly necessary due to outside temperature conditions. Do not use chemicals/acids to defrost windows/vehicle glass as they can damage the paint.

❑ Some versions are fitted with exclusive decorations on the door mirror covers; do not use pressurised or high-temperature jets of water when washing them.

Versions with stickers or wrapping

To correctly clean and wash the car, proceed as follows:

- ❑ avoid washing with rollers and/or brushes in washing stations. Then, wash the car, only by hand, using pH-neutral detergents; dry it with a wet chamois leather. Abrasive products and/or polishes should not be used for cleaning the car.
- ❑ The use of solvents, waxes, detergents or similar products is not recommended for the care of the car as they could damage the stickers or cause them to detach. The use of such washing or cleaning instruments and methods will therefore invalidate the warranty.

NOTE We recommend using mild products for cleaning the car.

- ❑ It should be remembered that a build up of water could cause damage, in the long term, to the car.
- ❑ Wet the bodywork with a low-pressure water jet.
- ❑ Wipe a sponge with a slightly soapy solution over the bodywork, frequently rinsing the sponge.

□ Rinse well with water and dry with a jet of air or a chamois leather. Dry the less visible parts with special care, such as the door frames, bonnet and the headlight frames, where water may stagnate more easily. The car should not be taken to a closed area immediately, but left outside so that residual water can evaporate. Do not wash the car after it has been parked in the sun.

Exterior plastic parts must be cleaned in the same way as the rest of the car. Where possible, do not park the car under trees; the resinous substances that many species release give the paint a dull appearance and increase the possibility of triggering rusting processes.

WARNING In case of water stains (rings) on the wrapping, remove it, washing again and drying it with a non-abrasive soft cloth.

WARNINGS

□ Bird droppings must be washed off immediately and thoroughly as the acid they contain is particularly aggressive.
□ Avoid (if at all possible) parking the car under trees; remove vegetable resins immediately as, when dried, it may only be possible to remove them with abrasive products and/or polishes,

which is highly inadvisable as they could alter the paint, the stickers or the wrapping.

□ Do not use pure windscreen washer fluid for cleaning the windscreen and the rear window: dilute it to at least 50% with water.

 73) 74)

Windows

To clean glasses, use specific cleaning products.

Use clean cloths to avoid scratching the glass or altering the transparency.

WARNING Wipe the rear window inside gently with a cloth following the direction of the filaments to avoid damaging the heating device.

Headlights

Use a soft cloth soaked in water and detergent for washing cars.

WARNING Never use aromatic substances (e.g. petrol) or ketones (e.g. acetone) for cleaning the plastic lenses of the headlights.

WARNING When cleaning the car with a pressure washer, keep the water jet at least 20 cm away from the headlights.

ENGINE COMPARTMENT WASHING

 75)

If the engine compartment is washed (at low pressure, e.g. in very dusty areas), this must be done with the engine cold and with ignition device turned to STOP. Take care not to direct the water jet straight at the electronic control modules or the wiper motors. Have this operation performed by a specialised workshop. After washing, check that the various protective components (e.g. rubber guards and caps) have not been removed or damaged.



IMPORTANT

72) *Abrasive products and/or polishes should not be used for cleaning the car. Bird droppings must be washed off immediately and thoroughly as the acid they contain is particularly aggressive. Avoid parking the vehicle under trees (unless it is absolutely necessary). Remove any resinous plant matter immediately because, once it has dried, it may require the use of abrasive and/or polishing products to be removed, which are strongly discouraged as they could potentially alter the characteristics of the paintwork. Do not use pure windscreen washer fluid for cleaning the front windscreen and rear window; dilute it min. 50% with water. Only use*



pure screen washer fluid when strictly necessary due to outside temperature conditions. Do not use chemicals/acids to defrost windows/vehicle glass as they can damage the paint.

73) *It is not advisable to wash with pressure washer or, in case of use, it is necessary to maintain at least a minimum distance of 40 cm with water at room temperature.*

74) *Abrasive products and/or polishes should not be used for cleaning the car*

75) *A high pressure jet cleaner should not be used for cleaning the engine compartment. The appropriate precautions have been taken to protect all parts and connections, but the pressures generated by these devices are so high that complete protection against water seepages cannot be guaranteed.*



IMPORTANT

6) *Detergents pollute the water. Only wash your vehicle in areas equipped to collect and treat waste water from this type of activity.*

INTERIOR

Regularly check that water is not trapped under the mats (due to water dripping off shoes, umbrellas, etc.), as this could cause oxidation of the sheet metal.



205) 206)

SEATS AND FABRIC PARTS

Remove dust with a soft brush or a vacuum cleaner. It is advisable to use a moist brush on velvet upholstery.

Rub the seats using a soft microfibre cloth moistened with a solution of water and neutral detergent.

PLASTIC AND COATED PARTS

It is advisable to clean interior plastic parts with a moist cloth and a solution of water and non-abrasive mild soap.

Use specific products for cleaning plastic, without solvents and specifically designed to prevent damage to the appearance and colour of the treated parts, to remove grease and tough stains.

WARNING Never use alcohol, petrols and derivatives to clean the instrument panel lens.

LEATHER AND SOFT TOUCH PARTS

(for versions/markets, where provided)

To clean these components, use a soft microfibre cloth moistened with a solution of water and neutral detergent. Before using a specific product for cleaning interiors, make sure that it does not contain alcohol and/or alcohol-based substances or solvents.

WOODEN INSERTS

(only for versions/markets, where provided)

Your car is characterised by premium inserts made of real wood. The exclusive finish of these materials needs to be cleaned carefully and gently: we suggest removing any dirt with a chamois leather or a damp cloth, while we do not recommend using solvents or detergents of any kind.



WARNING

205) *ever use flammable products, such as petrol ether or rectified petrol to clean the inside of the car. The electrostatic charges which are generated by rubbing during the cleaning operation may cause a fire.*

206) *Do not keep aerosol cans in the vehicle: they might explode. Aerosol cans must not be exposed to a temperature exceeding 50°C. When the vehicle*

is exposed to sunlight, the internal temperature can greatly exceed this value.



TECHNICAL SPECIFICATIONS

Everything you may find useful for understanding how your car is made and works is contained in this chapter and illustrated with data, tables and graphics. For the enthusiasts and the technician, but also just for those who want to know every detail of their car.

IDENTIFICATION DATA	189
ENGINE	191
INTAKE SYSTEM	193
TRANSMISSION	194
BRAKES	195
SUSPENSION.....	196
STEERING	197
WHEELS.....	198
DIMENSIONS	205
WEIGHTS AND LOADS.....	206
REFUELLING.....	208
FLUIDS AND LUBRICANTS	210
PERFORMANCE.....	213
FUEL CONSUMPTION AND CO ₂ EMISSIONS	214
PRESCRIPTIONS FOR HANDLING THE CAR AT THE END OF ITS LIFE.....	215

IDENTIFICATION DATA

It is advisable to take note of the identification codes. The following identification codes are printed and shown on the plates:

- Vehicle identification number (VIN) plate.
- Chassis marking.
- Bodywork paint identification plate (where provided).
- Motor marking.

VEHICLE IDENTIFICATION NUMBER (VIN) PLATE

It is applied to the left side of the rear floor in the luggage compartment or, depending on the version, on the passenger-side rear pillar. It contains the following information fig. 202:



202

FID1044

A Name of Manufacturer.

B Type-approval number.

C Car type identification code and progressive vehicle identification number (VIN).

D Maximum authorized weight of vehicle fully laden.

E Maximum authorised weight of fully laden car plus trailer.

F Maximum permitted weight on first axle (front).

G Maximum permitted weight on second axle (rear).

H Engine type.

I Bodywork version code.

L Spare part reference number.

M Fiat colour code (for versions/markets, where provided).

BODYWORK PAINT IDENTIFICATION PLATE

(where provided)

Depending on the version, the plate may be applied to the external tailgate pillar (left side) and contains the following information fig. 203:

A Paint manufacturer.

B Colour name.

C Fiat colour code.

D Respray and touch up code.



203

F0S0113

Alternatively, depending on the version, the Fiat Colour Code may be integrated in the type-approval data summary plate (M field fig. 202).

CHASSIS MARKING

It is located on the right side of the luggage compartment floor and bears the following data fig. 204:

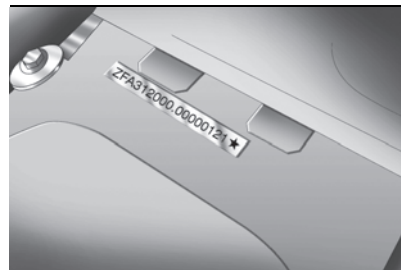

204

F0S0114

- car type;
- chassis serial number.



MOTOR MARKING

It is stamped on the cylinder block and includes the type and the engine serial number.

ENGINE CODE

0.9 TwinAir 85 HP: 312A2000

1.2 8V 69 HP/1.2 8V 69 HP Dualogic:
169A4000

1.0 FireFly Hybrid: 46341162

ENGINE

GENERAL INFORMATION	1.2 8V 69 HP	1.2 8V 69 HP LPG		0.9 TwinAir 85 HP(*)
Engine code	169A4000	169A4000		312A2000
Cycle	Otto	Otto		Otto
Number and position of cylinders	4 in line	4 in line		2 in line
Piston bore and stroke (mm)	70.8 × 78.86	70.8 × 78.86		80.5 × 86.0
Piston bore and stroke (mm)	1242	1242		875
Compression ratio	11.1 : 1	11.1 : 1		10 ± 0.2 : 1
		LPG	PETROL	
Maximum power (EC) (kW)	51	51	51	62.5
Maximum power (EEC) (HP)	69	69	69	85
corresponding engine speed (rpm)	5500	5500	5500	5500
Maximum torque (EEC) (Nm)	102	102	102	145
Maximum torque (EEC) (kgm)	10.4	10.4	10.4	14.8
corresponding engine speed (rpm)	3000	3000	3000	1900
Spark plugs	NGK ZKR7A-10 / Champion RA8MCX4		NGK ZKR7A-8	NGK LKR9EI-8
Fuel	Unleaded petrol 95 R.O.N. (EN228 specifications)	LPG for motor vehicles	Unleaded petrol 95 R.O.N. (EN228 specifications)	Unleaded petrol 95 R.O.N. (EN228 specifications)

(*) For versions/markets where provided



GENERAL INFORMATION	1.0 FireFly Hybrid
Engine code	46341162
Cycle	Otto
Number and position of cylinders	3 cylinders in line
Piston bore and stroke (mm)	70 x 86.5
Total displacement (cm ³)	999
Compression ratio	12: 1
Maximum power (CEE) (kW)	51
Maximum power (CEE) (HP)	70
corresponding revolutions per minute (rpm)	6000
Maximum torque (CEE) (Nm)	92
Maximum torque (CEE) (kgm)	9.38
corresponding revolutions per minute (rpm)	3500
Spark plugs	NGK LMAR8K-9S
Fuel	Unleaded petrol 95 R.O.N. (EN228 specifications)

INTAKE SYSTEM



Versions	Intake system
0.9 TwinAir 85 HP(*) 1.0 FireFly Hybrid	Phased sequential electronic injection with knock control and variable intake valve actuation
1.2 8V 69 HP	Multipoint sequential timed electronic injection, returnless system

(*) For versions/markets where provided

WARNING

207) Modifications or repairs to the fuel supply system that are not carried out properly or do not take the system's technical specifications into account can cause malfunctions leading to the risk of fire.



TRANSMISSION

Versions with manual transmission

Versions	Transmission	Clutch	Traction
1.2 8V 69 HP	Five/six forward speeds plus reverse with synchronisers for selecting forward gears	Self-adjusting pedal without idle stroke	Front
0.9 TwinAir 85 HP(*)			
1.0 FireFly Hybrid	Six forward gears plus reverse with synchronisers for forward gear engagement	Self-adjusting pedal without idle stroke	Front

(*) For versions/markets where provided

Versions with Dualogic transmission

Versions	Transmission	Clutch	Traction
1.2 8V 69 HP	Five forward speeds plus reverse with electronically managed electro-hydraulic control system	Electronically controlled electro-hydraulic system	Front

BRAKES

Versions	Front service brakes	Rear service brakes	Parking brake
1.2 8V 69 HP	Disc	Drum, self-centring shoes with control cylinder for each wheel	Controlled by handbrake lever, acting on the rear brakes
0.9 TwinAir 85 HP(*)			
1.0 FireFly Hybrid	Disc with floating caliper	Drum, self-centring shoes with control cylinder for each wheel	Manual, acting on rear brakes

(*) For versions/markets where provided

WARNING Water, ice and salt spread on the roads may deposit on the brake discs, reducing braking efficiency the first time the brakes are applied.



SUSPENSION

Versions	Front	Rear
1.2 8V 69 HP	MacPherson independent wheels with mechanical crossmember, shock absorbers and coil springs; with anti-roll bar for versions with electric power steering	Torsion beam with interconnected wheels consisting of a torsion axle and two tubular arms with shock absorbers and coil springs with anti-roll bar (*)
0.9 TwinAir 85 HP (*)	Independent wheels MacPherson layout, hydraulic shock absorbers, coil springs and anti-roll bar	Torsion beam and interconnected wheels, hydraulic shock absorbers, coil springs and anti-roll bar (*)

(*) For versions/markets where provided

STEERING

Versions	Kerb-to-kerb turning circle (m)	Type
1.2 8V 69 HP	9.3	Rack and pinion with electric power steering (*)
0.9 TwinAir 85 HP(*)	9.3	
1.0 FireFly Hybrid	9.3	Rack and pinion with electric power steering

(*) For versions/markets where provided



WHEELS

RIMS AND WHEELS

Pressed steel or alloy rims. Tubeless radial carcass tires. All approved tyres are listed in the registration document.

WARNING If there are any discrepancies between the Owner Handbook and the registration document, take the information from the latter. For safe driving, the car must be fitted with tyres of the same make and type on all wheels.

WARNING Do not use air chambers with tubeless tyres.

 211) 212)

SPACE-SAVER WHEEL

 213) 214)

Pressed steel rim.
Tubeless tyre.

WHEEL GEOMETRY

Front wheels toe-in measured between rims: 0.5 ± 1 mm.

The values refer to the car in running order.

CORRECT READING OF THE TYRE

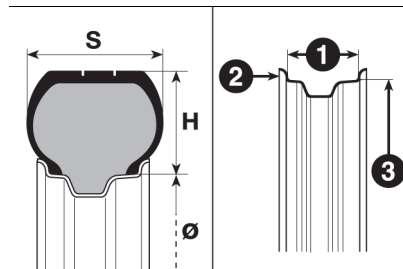

205

F0S0085

Example fig. 205: 175/65 R 14 82H

175 Nominal width (S, distance in mm between sides)

65 Height/width ratio (H/S), expressed as a percentage

R Radial tyre

14 Rim diameter in inches (Ø)

82 Load rating (capacity)

H Maximum speed rating

Maximum speed index

Q up to 160 km/h

R up to 170 km/h

S up to 180 km/h

T up to 190 km/h

U up to 200 km/h

H up to 210 km/h

V up to 240 km/h

Maximum speed index for snow tyres

QM + S up to 160 km/h

TM + S up to 190 km/h

HM + S up to 210 km/h

Load index (capacity)

70 = 335 kg **81** = 462 kg

71 = 345 kg **82** = 475 kg

72 = 355 kg **83** = 487 kg

73 = 365 kg **84** = 500 kg

74 = 375 kg **85** = 515 kg

75 = 387 kg **86** = 530 kg

76 = 400 kg **87** = 545 kg

77 = 412 kg **88** = 560 kg

78 = 425 kg **89** = 580 kg

79 = 437 kg **90** = 600 kg

80 = 450 kg **91** = 615 kg

CORRECT READING OF THE RIM CODE

Example fig. 205: 5,00 B x 14 H2

5.00 width of the rim in inches (1).

B drop centre outline (side projection where the tyre bead rests) (2).

14 fitting diameter, expressed in inches (corresponds to the diameter of the tyre that should be fitted) 3 = Ø.

H2 shape and number of "humps" (circumference measurement which keeps the bead of tubeless tyres in position on the rim).



RIMS AND TYRES PROVIDED

Versions	Rims	Tyres	Snow tyres	Space-saver wheel (*) Rim - Tyre
1.2 8V 69 HP	5½Jx14H2-ET35	175/65 R14 82T	175/65 R14 82Q (M+S)	
	5½Jx14H2-ET35	175/65 R14 86T	175/65 R14 82Q (M+S)	
	6Jx15H2-ET35 (**)	185/55 R15 82H (***)	185/55 R15 82Q (M+S)	4.00Bx14 ET43 – 135x80 R14 84P
	6Jx15H2-ET35 (**)	185/55 R15 86H (***)	185/55 R15 82Q (M+S)	4.00Bx14 ET43 – 135x80 R14 84M
	6½Jx16H2-ET35 (**)	195/45 R16 84H (***)	195/45 R16 84Q (M+S)	4.00Bx14 ET43 – 135x80 B14 84M
	6½Jx16H2-ET35 (**)	195/45 R16 84V (***)	195/45 R16 84Q (M+S)	
0.9 TwinAir 85 HP(*)	5½Jx14H2-ET35	175/65 R14 82T	175/65 R14 82Q (M+S)	
	5½Jx14H2-ET35	175/65 R14 86T	175/65 R14 82Q (M+S)	
	6Jx15H2-ET35 (**)	185/55 R15 82H (***)	185/55 R15 82Q (M+S)	4.00Bx14 ET43 – 135x80 R14 84M
	6Jx15H2-ET35 (**)	185/55 R15 86H (***)	185/55 R15 82Q (M+S)	4.00Bx14 ET43 – 135x80 R14 84P
	6½Jx16H2-ET35 (**)	195/45 R16 84H (***)	195/45 R16 84Q (M+S)	4.00Bx14 ET43 – 135x80 B14 84M
	6½Jx16H2-ET35 (**)	195/45 R16 84V (***)	195/45 R16 84Q (M+S)	

Versions	Rims	Tyres	Snow tyres	Space-saver wheel (*) Rim - Tyre
1.0 FireFly Hybrid	5½J x 14 H2-ET35	175/65 R14 86T (****)	175/65 R14 82Q (M+S)	4.00Bx14 ET43 – 135x80 R14 84P 4.00Bx14 ET43 – 135x80 R14 84M 4.00Bx14 ET43 – 135x80 B14 84M
	6J x 15 H2-ET35	185/55 R15 82H (**)	185/55 R15 82Q (M+S)	
	6J x 15 H2-ET35	185/55 R15 86H (**)	185/55 R15 82Q (M+S)	
	6½J x 16 H2-ET35	195/45 R16 84H (**)	195/45 R16 84Q (M+S)	
	6½J x 16 H2-ET35	195/45 R16 84V (**)	195/45 R16 84Q (M+S)	

(*) For versions/markets where provided

(**) Alloy wheel rim

(***) Chains cannot be fitted

(****) 14"; 7 mm chains can be fitted only



COLD TYRE INFLATION PRESSURE (bar)

 208) 209) 210)

When the tyres are warm, the inflation pressure should be + 0.3 bar in relation to the recommended figure. With snow tyres, add +0.2 bar to the pressure value prescribed for other standard tyres. However, recheck the correct value when the tyre is cold.

Tyres	Medium load		Full load		Space-saver wheel (*)
	Front	Rear	Front	Rear	
175/65 R14 82T (**)	2.2	2.0	2.3	2.2	2.8
175/65 R14 86T (**)	2.2	2.0	2.3	2.2	
185/55 R15 82H	2.2	2.1	2.3	2.3	
185/55 R15 86H	2.2	2.1	2.3	2.3	
195/45 R16 84H (**)	2.2	2.1	2.4	2.3	
195/45 R16 84V (**)	2.2	2.1	2.4	2.3	

(*) For versions/markets where provided

(**) The indicated pressure is aimed at comfort. To privilege fuel efficiency, the inflation pressure can be increased to a maximum of 2.8 bar on the front tyres and up to 2.6 bar on the rear tyres.



WARNING

208) If the car is unused for long periods of time, it is necessary to ensure that the tyre pressures are correct and reset the iTPMS from the menu before using it again. See the "iTPMS" paragraph in the "Safety" chapter.

209) Remember that the road holding qualities of your car also depend on correct tyre pressures.

210) If tyre pressure is too low, it may overheat and be severely damaged as a result.

RIM PROTECTOR TYRES

For wheel hub caps fitting on rims with Rim Protector tyres, see the warning below.

 218)

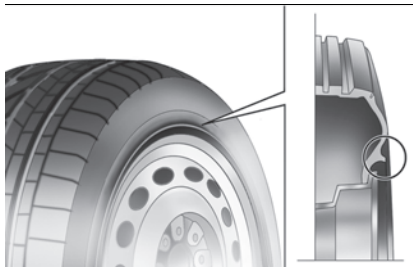

206

F0S0351

SNOW TYRES

 219)

Use snow tyres of the same size as the standard tyres provided with the car.

All four tyres should be the same (brand and track) to ensure greater safety when driving and braking as well as a good manoeuvrability.

Remember that you should not change the rotation direction of the tyres.

The Fiat Dealership will be happy to provide advice concerning the most suitable type of tyre for the customer's requirements.

The winter features of these tyres are reduced considerably when the tread

depth is below 4 mm. Replace them in this case.

Due to the specific characteristics of snow tyres, in normal weather conditions or on long motorway journeys, the performance of these tyres is lower than that of standard tyres. Their usage should therefore be restricted in accordance with their type approval.

WARNING When using snow tyres with a maximum speed index below the one that can be reached by the car (increased by 5%), place a notice in the passenger compartment, plainly in view, which states the maximum speed allowed by the snow tyres (as per EC Directive). All four tyres should be the same (brand and track) to ensure greater safety when driving and braking as well as a good manoeuvrability. Remember that you should not change the rotation direction of the tyres.

SNOW CHAINS

 76) 77) 78)

The use of snow chains should be in compliance with local regulations of each country. In certain countries, tyres marked with code M+S (Mud and Snow) are considered as winter

equipment; therefore their use is equivalent to that of the snow chains. Snow chains can be fitted to the tyres of the front wheels (drive wheels) only. Check the tension of the snow chains after the first few feet/meters have been driven.

Using snow chains with tyres with non-original dimensions may damage the car. Using different size or type (M+S, snow, etc.) tyres between front and rear axle may adversely affect car driveability, with the risk of losing control of the car and resulting accidents.

WARNING Snow chains cannot be fitted to the space-saver wheel. If a front tyre is punctured, replace a rear wheel with the space-saver wheel and move the rear wheel to the front axle. In this way, with two normal drive wheels at the front, snow chains can be fitted.



WARNING

211) Do not switch tyres from the right-hand side of the car to the left-hand side, and vice versa.

212) Never submit alloy rims to repainting treatments requiring the use of temperatures exceeding 150°C. The mechanical properties of the wheels could be impaired.

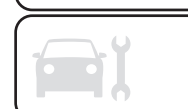

213) *The space-saver wheel (for versions/markets where provided) is specific to your car, do not use it on other models, nor use the space-saver wheel of other models on your car. The space-saver wheel must only be used in the event of an emergency. Never use it for more than strictly necessary and never exceed a speed of 80 km/h.*

214) *Snow chains cannot be fitted to the space-saver wheel. So, if a front (drive) wheel is punctured and chains are needed, a rear wheel should be fitted to the front of the car and the space-saver wheel should be fitted to the rear. In this way, equipped with two normal drive wheels at the front, they can be fitted with snow chains, thus resolving the emergency situation.*

215) *If the car is unused for long periods of time, it is necessary to ensure that the tyre pressures are correct and reset the iTPMS from the menu before using it again. See the "iTPMS" paragraph in the "Safety" chapter.*

216) *Remember that the road holding qualities of your car also depend on correct tyre pressures.*

217) *If tyre pressure is too low, it may overheat and be severely damaged as a result.*

218) *Do NOT fit wheel cups when using integral cups fixed (with springs) to the steel rim and tyres other than factory-fitted tyres provided with Rim Protector (fig. 206). Use of unsuitable tyres and wheel caps may cause sudden decrease of tyre pressure.*

219) *The top speed for snow tyres marked "Q" is 160 km/h, while it is 190 km/h for*

"T" tyres and 210 km/h for "H" tyres. Nevertheless, you must always comply with the highway code speed limits.



IMPORTANT

76) *Keep the vehicle's speed down when snow chains are fitted; never exceed 50 km/h.*

77) *With snow chains, use the accelerator with extreme care to prevent, or to limit as much as possible, slipping of the drive wheels that could cause chain breakage, resulting in damage to the vehicle body or mechanical components.*

78) *Avoid potholes, steps and pavements and avoid driving long distances on roads not covered with snow to avoid damaging the car and the road surface.*

DIMENSIONS

Dimensions are expressed in mm and refer to the vehicle equipped with its standard-supplied tyres. Height is measured with car unladen.

BOOT VOLUME *Petrol versions:* capacity (VDA standards): 185 litres. *LPG versions:* capacity (VDA standards): 165 litres.

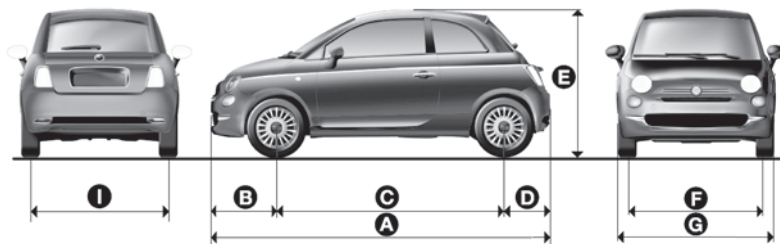

207

F0S0605

Versions	A	B	C	D	E	F	G	I
0.9 TwinAir 85 HP(*)	3571	720	2300	551	1488(*)	1413 / 1414(**)	1627	1407 / 1408(**)
1.2 8V 69 HP	3571	720	2300	551	1488(*)	1413	1627	1407
1.0 FireFly Hybrid	3571	720	2300	551	1488(*)	1413	1627	1407

(*) For versions/markets, where provided

(*) Measurements may vary according to rim/tyre size.

(**) With 195/45 R16 tyres



WEIGHTS AND LOADS

To identify the weights and masses of your car, refer to the car registration document containing the type-approved weights (for markets where provided) or the plate applied to the rear floor under the boot lining, next to the spare wheel compartment.

For versions/markets where provided, the plate may be on the driver's door pillar.



208

F1D1045

(D) Maximum authorised weight of fully laden car (GVW).

(E) Maximum authorised weight of fully laden car (GVW) plus trailer. If trailer towing is not permitted, values (D) and (E) are equal.

(F) Maximum permitted weight on front axle.

(G) Maximum permitted weight on rear axle. To calculate the towable weight

with a braked trailer, take the difference between values (E) and (D) shown on the plate.

E.g.: E = 1455 Kg - D = 655 Kg

Braked trailer = 800 kg

WARNING Do not exceed the indicated trailer and towable weights.

WARNING Observe the car towing capacities.

For the 1.0 FireFly Hybrid version

WARNING A trailer cannot be towed so there are no provisions for fitting a tow hook.

TOWABLE WEIGHTS (KG)

Key:

A = UNBRAKED TRAILER

B = LOAD ON TOW HOOK

VERSION (GVW)	ENGINE	A	B
500/500C	0.9 TwinAir 85 HP(*)	400	60

(*) For versions/markets where provided

WARNING Versions not in this table cannot tow trailers.



REFUELLING

	1.2 8V 69 HP / 1.2 8V 69 HP LPG	0.9 TwinAir 85 HP(*)	Prescribed fuels and original lubricants
Fuel tank (petrol - litres):	35 / 30.5(***)	35	Unleaded petrol with at least 95 R.O.N. (EN228 specifications)
including a reserve of (litres):	5.0	5.0	
Engine cooling system (litres):	4.85 / 5.2 (**)	5.3	50% mixture of distilled water and PARAFLU ^{UP} (*)
Engine sump (litres):	–	2.8	SELENIA DIGITEK P.E.
	2.5	–	SELENIA ECO2
Engine sump and filter (litres):	–	3.2	SELENIA DIGITEK P.E.
	2.8	–	SELENIA ECO2
Gearbox/differential casing (litres):	1.65	1.65	TUTELA TRANSMISSION GEARFORCE
Dualogic transmission hydraulic activation system:	0.70 (litres) / (0.59) kg	–	TUTELA CS SPEED Special oil with "ATF DEXRON III" type additive
Hydraulic brake circuit (kg):	0.55	0.55	TUTELA TOP 4/S
Hydraulic clutch controls (RH drive versions)	0.100	–	
Windscreen and rear window washer fluid reservoir (litres):	2.5	2.5	Mixture of water and PETRONAS DURANCE SC35

(*) For versions/markets, where provided

(*) When the vehicle is used in particularly harsh weather conditions, we recommend using a 60% mixture of PARAFLU^{UP} and 40% demineralised water.

(**) LPG versions

(***) LPG versions (including reserve). The figure already takes into account the 80% tank filling limit and the residual fluid required for priming and the maximum permitted capacity. In addition, after different refuelling processes, this figure may vary due to differences between the network pump supply pressures, pumps having different supply/locking features, tank not completely run out of fuel.

	1.0 FireFly Hybrid	Prescribed fuels and original lubricants
Fuel tank (petrol - litres):	35	Unleaded petrol with at least 95 R.O.N. (EN228 specifications)
including a reserve of (litres):	5.0	
Engine cooling system (litres):	4.4	50% mixture of distilled water and PARAFLU ^{UP} (*)
Engine sump (litres):	2.2	SELENIA ECO2
Engine sump and filter (litres):	2.5	SELENIA ECO2
Gearbox casing/differential:	1.65 kg/1.94 litres	TUTELA TRANSMISSION GEARFORCE
Hydraulic brake circuit (kg):	0.55	TUTELA TOP 4/S
Windscreen and rear window washer fluid reservoir (litres):	2.5	Mixture of water and PETRONAS DURANCE SC35

(*) When the vehicle is used in particularly harsh weather conditions, we recommend using a 60% mixture of PARAFLU^{UP} and 40% demineralised water.



FLUIDS AND LUBRICANTS

Your car is equipped with an engine oil that has been thoroughly developed and tested in order to meet the requirements of the Scheduled Servicing Plan. Constant use of the prescribed lubricants guarantees the fuel consumption and emission specifications. Lubricant quality is crucial for engine operation and duration. If lubricants conforming to the required specifications are not available, products that meet the indicated specifications can be used to top up; in this case optimal performance of the engine is not guaranteed.



PRODUCT SPECIFICATIONS

Use	Features	Specification	Original liquids and lubricants	Replacement interval
Lubricants for 0.9 TwinAir 85 HP petrol engines (*)	SAE 0W-30 ACEA C2 / API SN	9.55535-GS1	SELENIA DIGITEK P.E. Contractual Technical Reference N° F020.B12	According to Scheduled Servicing Plan
Lubricants for 1.2 8V 69 HP petrol engines	SAE 0W-20 ACEA C5	9.55535-DM1	SELENIA ECO2 Contractual Technical Reference N° F049.C18	According to Scheduled Servicing Plan
Lubricant for petrol/LPG engines				
Lubricants for 1.0 FireFly Hybrid petrol engines	SAE 0W-20 ACEA C5	9.55535-DM1	SELENIA ECO2 Contractual Technical Reference N° F049.C18	According to Scheduled Servicing Plan

(*) For versions/markets, where provided

For TwinAir engines only use lubricants with indicated SAE grade and specifications.

Use	Features	Specification	Original fluids and lubricants	Applications
Lubricants and greases for drive transmission	SAE 75W API GL4 grade synthetic lubricant.	9.55550-MZ6	TUTELA TRANSMISSION GEARFORCE Contractual Technical Reference N° F002.F10	Manual gearbox and differential
	Specific fluid for electro hydraulic actuators "ATF DEXRON III".	9.55550-SA1	TUTELA CS SPEED Contractual Technical Reference N° F005.F98	Dualogic transmission activation hydraulic system oil
	Molybdenum disulphide grease, for use at high temperatures. N.L.G.I. consistency 1-2.	9.55580-GRAS II	TUTELA ALL STAR Contractual Technical Reference N° F702.G07	Wheel side constant velocity joints
	Low friction coefficient grease for constant velocity joints. N.L.G.I. consistency 0-1.	9.55580-GRAS II	TUTELA STAR 700 Contractual Technical Reference N° F701.C07	Differential side constant velocity joints
Brake fluid	Synthetic fluid for brake and clutch systems. Exceeds specifications F.M.V.S.S. no. 116 DOT 4, ISO 4925 SAE J1704.	9.55597 or MS.90039	TUTELA TOP 4/S Contractual Technical Reference N° F005.F15	Hydraulic brakes and hydraulic clutch controls
Protective agent for radiators	Protective agent with antifreeze action with organic formulation. CUNA NC 956-16, ASTM D 3306 Specifications.	9.55523 or MS.90032	PARAFLU^{UP} (*) Contractual Technical Reference N° F101.M01	Cooling circuits proportions of use: 50% water 50% PARAFLU^{UP} (**)



Use	Features	Specification	Original fluids and lubricants	Applications
Windscreen/rear window washer fluid	Mixture of alcohol, water and surfactants CUNA NC 956-II.	9.55522 or MS.90043	PETRONAS DURANCE SC35 Contractual Technical Reference N° F001.D16	To be used diluted or undiluted in windscreen washer/wiper systems

(*) IMPORTANT Do not use fluids with different specifications for topping up or mixing.

(**) For particularly harsh climate conditions, a mixture of 60% PARAFLUUP and 40% distilled water is recommended.



IMPORTANT

79) *The use of products with different specifications than those indicated below could cause damage to the engine not covered by the warranty.*

PERFORMANCE

Max. speed in km/h that can be reached after initial car use.

Versions	Maximum speed (km/h)
0.9 TwinAir 85 HP (*)	173
1.2 8V 69 HP	160
1.2 8V 69 HP LPG	160
1.0 FireFly Hybrid	167 (in 5 th gear)

(*) For versions/markets where provided



FUEL CONSUMPTION AND CO₂ EMISSIONS

The fuel consumption and CO₂ emission figures declared by the manufacturer are determined on the basis of the type-approval tests laid down by the applicable standards in the country where the car is registered.

The type of route, traffic conditions, weather conditions, driving style, general condition of the car, trim level/equipment/accessories, use of the climate control system, car load, presence of roof racks and other situations that adversely affect the aerodynamics or wind resistance lead to different fuel consumption values than those measured. The fuel consumption will only become more regular after driving the first 3000 km. To find the specific fuel consumption and CO₂ emission figures for this car, please refer to the data in the Certificate of Conformity, and the related documentation that accompanies the car.

PRESCRIPTIONS FOR HANDLING THE CAR AT THE END OF ITS LIFE

The manufacturer has been committed for many years to safeguarding the environment through the constant improvement of its production processes and manufacturing products that are increasingly "eco-compatible". To grant customers the best possible service in terms of respecting environmental laws and in response to European Directive 2000/53/EC governing vehicles at the end of their life, the manufacturer is offering its customers the chance to hand over their vehicles at the end of their life without incurring any additional costs. The European Directive sets out that when the vehicle is handed over, the last keeper or owner should not incur any expenses as a result of it having a zero or negative market value.

To hand your vehicle over at the end of its life without extra cost, contact one of our dealerships if you are purchasing another vehicle or a collection and scrapping centre authorised by the Manufacturer. These centres have been carefully chosen to offer high quality service for the collection, treatment and recycling of vehicles at their end of life, respecting the surrounding environment.

You can find further information on these collection and scrapping centres either from a Stellantis dealership or by calling the number in the Warranty Booklet or by consulting the websites of the various manufacturer brands.





*This chapter describes the main functions of the **Uconnect™** Radio, **Uconnect™** 5", **Uconnect™** 5" Nav, **Uconnect™** 7" HD and **Uconnect™** 7" HD NAV infotainment systems that can be fitted on the vehicle.*

MULTIMEDIA

TIPS, CONTROLS AND GENERAL INFORMATION	217
USB SOURCE	218
UCONNECT™ RADIO	219
RADIO / RADIO DAB+	226
Uconnect™ 5" Radio / NAV	231
Uconnect™ 7 HD/ NAV.....	242
MOPAR® CONNECT.....	254
OFFICIAL TYPE APPROVALS	255
RIGHT-HAND DRIVE VERSION	257

TIPS, CONTROLS AND GENERAL INFORMATION

Road safety

Learn how to use the various system functions before setting off. Read the instructions for the system carefully before setting off.

Reception conditions

Reception conditions change constantly while driving. Reception may be interfered with by the presence of mountains, buildings or bridges, especially when you are far away from the broadcaster.

WARNING The volume may be increased when receiving traffic information and news.

Care and maintenance

Observe the following precautions to ensure the system is fully operational:

- ❑ the display is sensitive to scratching, liquids and detergents. Avoid hitting the display with pointed or hard objects that could damage its surface. Do not press on the display when cleaning it.
- ❑ do not use alcohol, petrol and derived products to clean the display lens, and make sure that the

Uconnect™ system is switched off during cleaning.

- ❑ prevent any liquid from entering the system: this could damage it beyond repair.

Anti-theft protection

The system is equipped with an anti-theft protection system based on the exchange of information with the electronic control unit (Body Computer) on the vehicle.

This guarantees maximum safety and prevents the secret code from being entered after the power supply has been disconnected.

If the check has a positive outcome, the system will start to operate, whereas if the comparison codes are not the same or if the electronic control unit (Body Computer) is replaced, the system will ask the user to enter the secret code according to the procedure described in the paragraph below.

Entering the secret code

When the system is switched on, if the code is requested, the display will show "Please enter Anti-Theft Code" followed by the screen showing a keypad to enter the secret code. The secret code is made up of four digits from 0 to 9. If an incorrect code is entered, the system displays "Incorrect Code" to

notify the user of the need to enter the correct code.

After the 3 available attempts to enter the code, the system displays "Incorrect Code. Radio locked. Please wait for 30 minutes". After the text has disappeared it is possible to start the code entering procedure again.

Car radio passport

This document certifies ownership of the system. The car radio passport shows the system model, serial number and secret code.

WARNING Keep the car radio passport in a safe place so that you can give the information to the relevant authorities if the system is stolen. In case of loss of the car radio passport, contact the Fiat Dealership, taking an ID document and the car ownership documents.

Warnings

In the event of an anomaly, the system should only be checked and repaired at a Fiat Dealership.

If the temperature is particularly low, the display may take a while to reach optimum brightness.

If the car is stopped for a while and the external temperature is very high, the system may go into "thermal protection" mode, suspending



operation until the temperature in the passenger compartment returns to acceptable levels.

Look at the screen only and when it is necessary and safe. If you need to look at the screen for a long time, pull over to a safe place so as not to be distracted while driving.

Immediately stop using the system in the event of a fault. Otherwise the system might be damaged. Contact a Fiat Dealership as soon as possible to have the system repaired.

USB SOURCE

To activate the USB mode, insert the corresponding device into the USB port on the central tunnel in the car.

WARNING After using a USB recharging socket, we recommend disconnecting the device (smartphone), always removing the cable from the vehicle socket first, never from the device. Cables left flying or connected incorrectly could compromise correct recharging and/or the USB socket condition.

NOTE The USB port handles data transmission from the Pen Drive/Smartphone, etc. and slow recharging of an external device, which

is not guaranteed as it depends on the device type/brand.

UCONNECT™ RADIO

CONTROLS ON FRONT PANEL







209





F0S0756

A. 1.2 8V 69 HP and 0.9 TwinAir B versions. 1.0 FireFly Hybrid version



FRONT CONTROL PANEL SUMMARY TABLE

Button	Functions	Mode
	Ignition	Short button press
	Switching off	Short button press
	Volume adjustment	Turning the knob clockwise/anticlockwise
	Volume activation/deactivation (Mute/Pause)	Short button press
	Exit the selection/return to previous screen	Short button press
BROWSE ENTER	Scrolling the list or tuning to a radio station or select previous/next track	Turning the knob clockwise/anticlockwise
	Confirmation of the option displayed	Short button press
INFO	Display mode selection (Radio, Media Player)	Short button press
AUDIO	Access to the sound setting and adjustment functions	Short button press
MENU	Access to the Settings menu	Short button press
MEDIA	USB source selection	Short button press
RADIO	Access to the Radio mode	Short button press
1-2-3-4-5-6	Store current radio station	Long button press
	Stored radio station recall	Short button press
A-B-C	Selection of the group of radio presets or selection of the desired letter in each list	Short button press
	Search for previous radio station or selection of USB previous track	Short button press

Button	Functions	Mode
	Scan of lower frequencies until released/Fast rewind of USB track	Long button press
	Search for next radio station or selection of USB next track	Short button press
	Scan of higher frequencies until released/Fast forward of USB track	Long button press
	Shuffle of USB tracks	Short button press
	USB loop	Short button press



STEERING WHEEL CONTROLS



(where provided)

The controls for the main system functions are present on the steering wheel to make control easier. The activation of the function selected is controlled, in some cases, by how long the button is pressed (brief or long press) as described in the table below.



210

F0S0620

Button	Interaction (pressure/rotation)
	<ul style="list-style-type: none"> <input type="checkbox"/> Deactivate/reactivate the microphone during a phone conversation <input type="checkbox"/> Activation/deactivation of the USB source Pause <input type="checkbox"/> Activation/deactivation of the radio source Mute function
+/-	<ul style="list-style-type: none"> <input type="checkbox"/> Short press: volume increase/decrease in single steps <input type="checkbox"/> Long press: volume continuous increase/decrease until released
 	<ul style="list-style-type: none"> <input type="checkbox"/> Short press (Radio mode): selection of next/previous station <input type="checkbox"/> Long press (Radio mode): scan higher/lower frequencies until released <input type="checkbox"/> Short press (USB mode): selection of previous/next track <input type="checkbox"/> Long press (USB mode): fast forward/rewind until released
SRC	<ul style="list-style-type: none"> <input type="checkbox"/> select available audio sources: Radio or USB



SWITCHING THE SYSTEM ON/OFF

The system is switched on/off by pressing the button/knob .

Turn the button/knob clockwise to increase the radio volume or anticlockwise to decrease it.

RADIO (TUNER) MODE

The system is equipped with the following tuners: AM, FM and DAB (where provided).

Radio mode selection

Press the RADIO button on the front panel to activate radio mode.

Selecting a frequency band

The different tuning modes can be selected by pressing the RADIO button on the front panel.

NOTE The DAB frequency can be used in countries where digital transmission technology is available. The device will not be tuned to any frequency if the DAB button is pressed in a country where the service is not provided.

Information on the display

After the desired radio station is selected on the display, the following information is shown (INFO mode activated):

In the upper part: the preset station, the time and the other active radio settings are highlighted (e.g.: TA).

In the central part: the name of the current station, the frequency and the radio text information (if any) are highlighted.

FM/DAB station list



Press the BROWSE ENTER button/knob to display the complete list of the FM/DAB stations that can be received.

AM/FM radio station storage



The preset stations are available in all system modes and are selected by touching one of the presetting buttons **1-2-3-4-5-6** on the front panel.

If you are tuned to a radio station that you wish to store, hold down the button on the display which corresponds to the desired preset until an acoustic confirmation signal is emitted.



AM/FM radio station selection

To search for the desired radio station press the  or  button or use the wheel of the steering wheel controls , or alternatively turn the "BROWSE ENTER" knob.

Previous/next radio station search

Press briefly the  or  button or use the wheel of the steering wheel controls : when the button is released the previous or next radio station is displayed.

Previous/next radio station fast search

Hold down the  or  button to start the fast search: when the button is released, the first tunable radio is played.

DAB station list

Press the BROWSE ENTER button/knob to display:

- the list of all DAB stations;
- the list of stations filtered by "Genres";
- the list of stations filtered by "Ensembles" (broadcast group).

Within each list, the "ABC" graphic button allows the user to skip to the desired letter in the list.

Radio station alphabetic selection

The **A-B-C** button on the front panel can be used, depending on the chosen letter, to jump alphabetically to the first of the DAB stations available for that letter.

MEDIA MODE

This paragraph describes the ways of interacting with USB operation.

Audio source selection

Press the MEDIA button to select the USB audio source.

CHANGE TRACK (next/previous)

Briefly press the  button or turn the BROWSE ENTER button/knob

clockwise to play the next song. Briefly press the **◀◀** button or turn the BROWSE ENTER button/knob anticlockwise to return to the beginning of the song, or return to the beginning of the previous song if the current song has been playing for less than 3 seconds.

Fast forward/rewind through tracks

Press and hold down the **▶▶** button to fast forward the selected track or keep the **◀◀** button pressed to fast rewind the track.

Track selection (browse)

Use this function to scroll through and select the tracks on the active device. The choices available depend on the device connected.

For example, on a USB device, you can also use the BROWSE ENTER button/knob to scroll through the list of artists, genres and albums available on the device, depending on the information available in the tracks.

Within each alphabetical list, the **A-B-C** button on the front panel allows the user to skip to the desired letter in the list. Press the BROWSE ENTER button to activate this function on the source being played.

Turn the BROWSE ENTER button/knob to select the desired category and then

press the button/knob to confirm the selection.

Press the **⇒** button to cancel the function.

Track information display

Press the **INFO** button to select the information displayed while playing (Artist, Album, Genre, Name, Folder, File name). Press the **⇒** button to exit the screen.

Shuffle

Press the **⌘** button to play the tracks on USB in a random order.

Press again to deactivate the function.

Repeat

Press the **↺** button to activate this function. The corresponding icon is displayed.

Press again to deactivate the function.

NOTE The **Uconnect™** system may not support some USB keys: in this case, it will not automatically switch from "Radio" mode to "Media" mode. If the device used does not play, verify its compatibility by selecting Media mode: a dedicated message will appear on the **Uconnect™** system display.

SETTINGS

Press the MENU button on the front panel to display the "Settings" menu. NOTE The menu items displayed can vary according to the versions.

The menu includes the following items:

System Settings: Language, Restore Default Values, System Power Off, Volume Limited at Power On, Auto-On Radio.

Radio Menu: Browse FM Station List, Traffic Announcement (TA), Regional, Alternative Frequency (AF).

Radio Off Delay: lets you keep the system on for a preset time after turning the ignition key to the STOP position.

Audio mode

To access the "Audio" settings menu briefly press the AUDIO button on the front panel.

The menu includes the following items:

TREBLE: adjustment of high tones;

MID: adjustment of mid tones;

BASS: adjustment of bass tones;

BALANCE: balancing of left/right speakers;

SVC: speed adjustment according to vehicle speed;

LOUDNESS: audio improvement at low volume;



RADIO / RADIO DAB+











CONTROLS ON FRONT PANEL









211

F0S0754

FRONT CONTROL PANEL SUMMARY TABLE

Button	Functions	Mode
	Access to the Radio mode	Short press
	Go to Media mode to select of available sources	Short press
	Volume on/off (MUTE)	Short press
	Phone mode selection and acceptance of incoming phone call	Short press
	Ending of call in progress	Short press
	Exit the selection/return to previous screen	Short press
	Activation/deactivation of Play (playback) / Pause function	Short press
1 	Radio source: Select the radio station stored under "Preset 1" Media source: On/Off random playback of tracks in the device	Short press
	Radio source: Store the radio station currently playing under "Preset 1"	Long press
2 	Radio source: Select the radio station stored under "Preset 2" Media Mode: Select the previous track	Short press
	Radio source: Store the radio station currently playing under "Preset 2" Media Source: Fast backward track playback	Long press
	USB port	-
3 	Radio source: Select the radio station stored under "Preset 3" Media source: Select the next track	Short press



Button	Functions	Mode
3 	Radio source: Store the radio station under "Preset 3" Media Source: Fast forward track playback	Long press
4 	Radio source: Select the radio station stored under "Preset 4" Media source: On/Off repeat track / all tracks	Short press
	Access the settings menu	Long press
	On/off	Button press
	Volume adjustment	Turn knob
	Confirm displayed option	Short press
	Manual radio station search / Change selection up-down	Turn knob

CONTROLS ON THE STEERING WHEEL

(where provided)

The controls for the main system functions are located on the steering wheel for easy operation.

The activation of functions depends, in some cases, on how long the button is held down (short or long press) as described in the table on the following page.









212

F0S0622



STEERING WHEEL CONTROLS SUMMARY TABLE

Button	Function	Mode
	Volume activation/deactivation (Mute/Unmute)	Short press
+	Volume up single step	Short press
	Volume up fast	Long press
-	Volume down single step	Short press
	Volume down fast	Long press
	Automatic search for next radio station (Radio)/Next track (Media)/Go to previous menu item	Short press
	Automatic search for next radio station (Radio)/Fast forward (Media)/Go to previous menu item	Long press
	Automatic search for previous radio station (Radio)/Previous track (Media)/Go to next menu item	Short press
	Automatic search for previous radio station (Radio)/Rewind (Media)/Go to next menu item	Long press
	Answer an incoming call	Short press
	End the phone call in progress	Short press
	Press to activate Siri & Google Assistant	Short press

To view the handbook of this radio, go to <https://www.stellantisinfotainment.com/flat-500-radio/> or scan the QR Code available on the right



Uconnect™ 5" Radio / NAV

Controls on front panel

A



213

B







FOS0757

A. 1.2 8V 69 HP and 0.9 TwinAir B versions. 1.0 FireFly Hybrid version



Front control panel summary table

Button	Functions	Mode
	Switching on	Brief button press
	Switching off	Brief button press
	Volume adjustment	Left/right rotation of knob
	Volume activation/deactivation (Mute/Pause)	Brief button press
	Display on/off	Brief button press
	Exit the selection/return to previous screen	Brief button press
	Settings	Brief button press
BROWSE ENTER	Scrolling the list or tuning to a radio station	Left/right rotation of knob
	Confirmation of the option displayed	Brief button press
APPS	Access to the additional functions, e.g.: Time display, Compass (where applicable), external temperature, Media radio	Brief button press
PHONE	Phone data display	Brief button press
TRIP (Uconnect™ 5" versions)	Access to the Trip menu	Brief button press
NAV (Uconnect™ 5" Nav versions)	Access to the Navigation menu	Brief button press
MEDIA	Source selection: USB, Bluetooth®	Brief button press
RADIO	Access to the Radio mode	Brief button press

Steering wheel controls

The controls for the main system functions are present on the steering wheel to make control easier. The activation of the function selected is controlled, in some cases, by how long the button is pressed (short or long press) as described in the table below.









214

F0S0622



Steering wheel controls summary table

Text	Interaction (pressure/rotation)
	<ul style="list-style-type: none"> <input type="checkbox"/> Acceptance of incoming call; <input type="checkbox"/> Answering the second incoming call and putting the active call on hold; <input type="checkbox"/> Last 10 calls list on the instrument panel (with call browsing active and phone paired only)
	<ul style="list-style-type: none"> <input type="checkbox"/> Rejection of incoming call; <input type="checkbox"/> Ending of call in progress; <input type="checkbox"/> Exit the display on the instrument panel of the last calls (only with call browsing active)
	<ul style="list-style-type: none"> <input type="checkbox"/> Deactivation/reactivation of the microphone during a phone conversation; <input type="checkbox"/> Activation/deactivation of the USB, Bluetooth® source Pause; <input type="checkbox"/> Activation/deactivation of radio Mute function
	<ul style="list-style-type: none"> <input type="checkbox"/> Short press: volume increase/decrease in single steps; <input type="checkbox"/> Long press: volume continuous increase/decrease until released
	<ul style="list-style-type: none"> <input type="checkbox"/> Activation of voice recognition; <input type="checkbox"/> Interruption of the voice message in order to give a new voice command; <input type="checkbox"/> Interruption of voice recognition
	<ul style="list-style-type: none"> <input type="checkbox"/> Short press (Radio mode): selection of next/previous station <input type="checkbox"/> Long press (Radio mode): scan higher/lower frequencies until released <input type="checkbox"/> Short press (USB, Bluetooth® mode): selection of previous/next track <input type="checkbox"/> Long press (USB, Bluetooth® mode): fast forward/rewind until released <input type="checkbox"/> Short press (phone mode): selection of next/previous call (only with call browsing active)

Switching the system on/off

The system is switched on/off by pressing the  (ON/OFF) button/knob. Turn the button/knob clockwise to increase the radio volume or anticlockwise to decrease it.

Radio mode

After the desired radio station is selected, the following information is shown on the display:

At the top: the list of radio stations stored (preset) is displayed; the station currently playing is highlighted.

In the middle: display of the name of the current radio station and the buttons for selecting the previous or next radio station.

At the bottom: display of the following buttons:

- "Browse": list of the radio stations available;
- "AM/FM", "AM/DAB", "FM/DAB": selection of the desired frequency band (button reconfigurable according to the band selected: AM, FM or DAB);
- "Tune": manual radio station tuning (not available for DAB radio)
- "Info": additional information on the source being listened to;
- "Audio": access to the "Audio Settings" screen.

NOTE The DAB frequency can be used in countries where digital transmission technology is available. The device will not be tuned to any frequency if the DAB button is pressed in a country where the service is not provided.

Audio menu

The following adjustments can be carried out using the "Audio" menu:

- "Equalizer" (where provided);
- "Balance" (left/right audio balance adjustment);
- "Volume/Speed" (speed-dependent automatic volume control);
- "Loudness" (where provided);
- "Auto-On Radio";
- "Radio Off Delay".

To exit the "Audio" menu, press the  / Done graphic button.



Media mode



Audio source selection

Press the "Source" button to select the desired audio source among those available: USB or **Bluetooth®**.

Applications used on portable devices may be not compatible with the **Uconnect™** system.

Track selection (Browse)

With Media mode active, briefly press the  /  graphic buttons to play the previous/next track or keep the

 /  buttons pressed to fast rewind/forward the track.

NOTE For languages not supported by the system which feature special characters (e.g. Greek), the keyboard is not available. In these cases this function will be limited.

NOTE The **Uconnect™** system may not support some USB keys: in this case, it will not automatically switch from "Radio" mode to "Media" mode. If the device used does not play, verify its compatibility by selecting Media mode: a dedicated message will appear on the **Uconnect™** system display.

WARNING After using a USB recharging socket, we recommend disconnecting the device (smartphone), always removing the cable from the vehicle socket first, never from the device.

NOTE The USB ports handle data transmission from the Pen Drive/Smartphone, etc. and slow recharging of an external device, which is not guaranteed as it depends on the device type/brand.

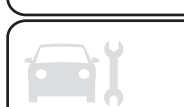

Bluetooth® source

Pairing a Bluetooth® audio device

To pair a **Bluetooth®** audio device, proceed as follows:

- activate the **Bluetooth®** function on the device;
- press the MEDIA button on the front panel;
- if the "Media" source is active, press the "Source" graphic button;
- select the **Bluetooth®** Media source;
- press the "Add Device" graphic button;
- search for **Uconnect™** on the **Bluetooth®** audio device (during the pairing stage a screen is displayed showing the progress of the operation);
- when requested by the audio device, enter the PIN code shown on the system display or confirm on the device the PIN displayed;
- if the pairing procedure is completed successfully, a screen is displayed. Answer "Yes" to the question to pair the **Bluetooth®** audio device as favourite (the device will have priority over all other devices to be paired subsequently). If "No" is selected, the priority is determined according to the order of connection. The last device connected will have the highest priority;

□ an audio device can also be paired by pressing the PHONE button on the front panel and by selecting "Settings" or, from the "Settings" menu, selecting "Phone/Bluetooth".

WARNING If the **Bluetooth®** connection between mobile phone and system is lost, consult the mobile phone handbook.

NOTE When modifying the name-device in the **Bluetooth®** settings of the phone (where provided), the Radio may change the track being played if the device is connected via USB after the **Bluetooth®** connection.

Phone mode

Phone mode activation

Press the PHONE button on the front panel to activate the Phone mode. Use the graphic buttons on the display to:

- dial the phone number (using the graphic dial pad on the display);
- display and call the contacts in the phonebook of the mobile phone;
- display and call contacts from the registers of previous calls;
- pair up to 10 phones/audio device to make access and connection easier and quicker;

□ transfer calls from the system to the mobile phone and vice versa and deactivate the microphone audio for private conversations.

The mobile phone audio is transmitted through the car's audio system; the system automatically mutes the radio when the Phone function is used.

NOTE To consult the list of mobile phones and supported functions, visit the www.driveuconnect.eu website

Pairing a mobile phone

To pair the mobile phone, proceed as follows:

- activate the Bluetooth® function on the mobile phone;
- press the PHONE button on the front panel;
- if no phone is paired with the system yet, the display shows a dedicated screen;
- select "Yes" to start the pairing procedure, then search for the **Uconnect™** device on the mobile phone (if "No" is selected, the Phone main screen is displayed);
- when prompted by the mobile phone, use its keypad to enter the PIN code shown on the system display or confirm on the mobile phone the PIN displayed;
- from the "Phone" screen you can always pair a mobile phone by pressing the "Settings" graphic button: press the

"Add Device" button and proceed as described above;

□ during the pairing stage a screen appears on the display showing the progress of the operation;

□ when the pairing procedure is completed successfully, a screen is displayed: answer "Yes" to the question to pair the mobile phone as favourite (the mobile phone will have priority over all other mobile phones to be paired subsequently). If no other devices are paired, the system will consider the first paired device as the favourite.

NOTE To ensure proper operation after updating the phone software, it is recommended to remove the phone from the list of devices linked to the radio, delete the previous system pairing also from the list of **Bluetooth®** devices on the phone and make a new pairing.

Making a phone call

The operations described below can only be accessed if supported by the mobile phone in use.

For all functions available, refer to the mobile phone owner's handbook.

A call can be made by:

□ selecting the  icon (mobile phone phonebook);

- selecting "Recent Calls";
- selecting the  icon;
- pressing the "Redial" graphic button.

Text Message Reader

The system can read the messages received by the mobile phone. To use this function, the mobile phone must support the text exchange function through **Bluetooth®**.

If this function is not supported by the phone, the corresponding graphic button  is deactivated (greyed out).

When a text message is received, the display will show a screen where the options "Listen", "Call" or "Ignore" can be selected.

Press the  graphic button to access the list of text messages received by the mobile phone (the list displays a maximum of 60 messages received).

NOTE On some mobile phones, to make the text message voice reading function available, the text message notification option on the phone must be enabled; this option is usually available on the phone, in the **Bluetooth®** connections menu for a device registered as **Uconnect™**. After enabling this function on the mobile phone, it must be disconnected and reconnected with the **Uconnect™** system in order to make it effective.

Text message options

Default text messages are stored in the system memory and can be sent to answer a received message or as a new message:

- Yes.
- No.
- Okay.
- I can't talk right now.
- Call me.
- I'll call you later.
- I'm on my way.
- Thanks.
- I'll be late.
- Stuck in traffic.
- Start without me.
- Where are you?
- Are you there yet?
- I need directions.
- I'm lost.
- See you later.
- I will be 5 (or 10, 15, 20, 25, 30, 45, 60)* minutes late.
- See you in 5 (or 10, 15, 20, 25, 30, 45, 60)* minutes.

* Only use the numbers listed, otherwise the system will not take the message.

NOTE See the dedicated section for details on how to send a text message using the voice commands.



APPS Mode

Press the APPS button on the front panel to display the following operating settings:

- External temperature
- Clock
- Compass (NAV versions only)
- Trip (for versions/markets, where provided)

my:Car

my:Car allows you to keep the condition of your car always under control.

my:Car can detect malfunction in real time and inform the user about the expiry of the servicing interval. Press the "my:Car" button to interact with the application.

The display will show a screen with the "care:Index" section, which provides all the detailed information about the status of the vehicle. Press the "Active warnings" button (if present) to show the details of the faults of the car which caused a warning light to switch on.

The car's status can be viewed on both the www.driveuconnect.eu and via the **Uconnect™ LIVE App**.

Settings

Press the  button on the front panel to display the "Settings" main menu.

NOTE The menu items displayed vary according to the versions. The menu includes the following items:

- Display;
- Units;
- Voice Commands;
- Clock & Date;
- Lights (where provided);
- Doors & Locks;
- Engine Off Options;
- Audio;
- Phone / **Bluetooth®**;
- Setup SiriusXM (where provided);
- Radio Setup;
- Restore Settings;
- Clear Personal Data.

Navigation (Uconnect™ 5" Nav only)

Planning a route

WARNING In the interest of safety and to reduce distractions while you are driving, you should always plan a route before you start driving.

Press the "Nav" button to show the navigation map on the display.

To plan a route, do the following:

- tap the screen to open the Main menu;

- tap "Navigate to";
 - tap "Address". You can change the country or state setting by tapping the flag before you select a city;
 - enter the town or city name, or the postcode. Towns with similar names are shown in the list while you type;
 - enter the street name. Streets with similar names are shown in the list while you type. When the correct street name appears in the list, tap the name to select the destination;
 - enter the house number, then tap "Done";
 - if in the Advanced settings menu the "Show location preview" option is active, your position is shown on the map. Tap "Select" to continue or tap "Back" to enter another address;
 - when the new route is shown, tap "Done". For more information about the route, tap on "Details". To modify the route, for example, to pass through a specific location or select a new destination, touch "Change route"; You are guided to your destination, using spoken instructions and on-screen directions.
- NOTE: The navigation system volume can only be adjusted during navigation when the system provides voice indications.

Updating the map

Two modes for downloading a map update are available:

- ❑ Most recent maps guarantee: if a new map is available for your system within 90 days of initial use, you can download it once free of charge.
- ❑ Map update: you can purchase a new version of the map installed on the system. To check availability or purchase a map, make sure that you have prepared a USB device and installed TomTom HOME on your computer.

Preparing a USB device

To update the map, use a USB device that meets the following requirements.

- ❑ The USB device should preferably be empty.
- ❑ The USB device must have at least 8 GB of free memory.
- ❑ The USB device must have a FAT-32 file system.
- ❑ The USB device must not be blocked and must allow files to be saved.

NOTE: the use of a memory stick is recommended, while the use of mass storage devices, such as mobile phones or multimedia players, is not recommended.

To prepare a USB device, proceed as follows:

- ❑ Select "Navigation updates" in

the "Settings" menu. You are asked whether you wish to prepare a USB device for downloading updates.

- ❑ Select Yes.
- ❑ Insert the USB device.

NOTE If the system continues to ask you to insert the USB device, check that the device meets the requirements indicated previously, then retry. The system starts to prepare the USB device.

When the USB device is ready, the following message is displayed.

Remove the USB device and connect it to the computer. The new map can now be downloaded to the USB device.

TomTom HOME installation

To install TomTom HOME and create a MyTomTom account, proceed as follows:

- ❑ Download and install the TomTom HOME application on the computer. On the computer, access tomtom.com/getstarted. Select "Download TomTom HOME", then follow the instructions provided.
- ❑ Connect the USB device prepared with the computer. TomTom HOME is started automatically.
- ❑ Select "Log in" in the top right corner of TomTom HOME.

- ❑ Select "Create account" and enter the required details to create a MyTomTom account. A MyTomTom account is required to receive map updates. After creating the account, you will be asked if you want to connect the **Uconnect™** system to your account.

The prepared USB device represents your **Uconnect™** system.

- ❑ Select "Connect device" and then select "Close".

A map can now be downloaded to the USB device.

Downloading a map

Connect the USB device to the computer.

If a map update is available for the system, this update is included in the list of updates available.

NOTE If the most recent map is already installed on the system, the update is not proposed. Select the map that you wish to download, then select "Update and install".

The map is downloaded and copied to your USB device.

Select "Done" when the process is complete.

NOTE Don't disconnect the USB device from the computer while map downloading and copying is in progress.



The map can now be installed on the system.

Installing the map

After downloading a map to your USB device, it can be installed on your system.

WARNING The map update **MUST** be made with the vehicle engine running and may require more than 30 minutes.

WARNING Do not disconnect the USB device during the map installation process, otherwise installation will be interrupted.

❑ Insert the USB device containing the new map in the **Uconnect™** system. The system detects a new map on the USB device.

❑ Select "Start".

Keep the device inserted. Before updating the map, the system indicates that this process may take several minutes. Select "OK".

NOTE Do not remove the USB device and do not disconnect the system's power supply before the update is complete. The system cannot be used until the update is completed correctly. If the update is interrupted, the system update is started again.

Once the map has been updated, the following message is displayed.

❑ Click on "Close".

The new map is now available on the system.

Troubleshooting

The following problems may occur during the update:

❑ The map on the USB device is not valid. In this case, download the map to the USB device again, using TomTom HOME. It may be necessary to prepare the USB device again.

❑ The version of the map on the USB device is the same as or is a previous version of the one already on the system. In this case, download the map to the USB device again, using TomTom HOME. It may be necessary to prepare the USB device again.

Voice Commands

NOTE For languages not supported by the system, voice commands are not available. To use the voice commands, press the button on the steering wheel  ("Voice" button) and say out loud the command you want to activate.

Global

The following voice commands can be given after pressing the button on the steering wheel  :

❑ Help

- ❑ Cancel
- ❑ Repeat
- ❑ Voice tutorial

Phone

The following voice commands can be given after pressing the  button on the steering wheel and saying "Go to telephone":

- ❑ Call
- ❑ Dial
- ❑ Redial
- ❑ Call back
- ❑ Show recent calls
- ❑ Show outgoing calls
- ❑ Show missed calls
- ❑ Show incoming calls
- ❑ Phonebook
- ❑ Search
- ❑ Show text message

Radio

The following voice commands can be given after pressing the button on the steering wheel  :

- ❑ Tune to XXX FM
- ❑ Tune to XXX AM
- ❑ Tune in Radio XXX
- ❑ Tune in channel DAB

Media

The following voice commands can be given after pressing the button on the steering wheel  :

- ❑ Play song...

- Play album...
- Play artist...
- Play genre...
- Play playlist...
- Play podcast...
- Play audiobook...
- Select the source
- View

Navigation (Uconnect™ 5" Nav only)

The following voice commands can be given after pressing the button on the steering wheel  :

- Navigate home
- 2D vision
- 3D vision
- Clear route
- Add Favourite
- Repeat instruction

NOTE Voice entry of addresses is only supported in the country in which you are located and only if the system language matches the local language. For example, if the car is located in Italy, it will be possible to enter Italian addresses only if the system language is set to "Italian".



Uconnect™ 7 HD/ NAV**Controls on front panel****A**





215

B

F0S0758

A. 1.2 8V 69 HP and 0.9 TwinAir B versions. 1.0 FireFly Hybrid version

Front control panel summary table

Button	Functions	Mode
	Ignition	Short button press
	Switching off	Short button press
	Volume adjustment	Left/right rotation of knob
	Volume activation/deactivation (Mute/Pause)	Short button press
	Display on/off	Short button press
	Exit the selection/return to previous screen	Short button press
SCROLL TUNE	Scrolling the list or tuning to a radio station Media source track change Radio station change if in tuner mode	Left/right rotation of knob
	Confirmation of the option displayed Display the list of stations if in Radio mode Scroll the contents of the sources if in Media mode Open the browsing list if in Radio or Media mode	Short button press

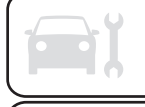

Summary table of display buttons

Button	Functions	Mode
Radio	Access to the Radio mode	Press graphic button
Media	Source selection: USB, Bluetooth®	Press graphic button
Phone	Phone data display	Press graphic button
Uconnect™	Access to the additional functions (e.g. compass display)	Press graphic button
Nav(*)	Access to the navigation function	Press graphic button
Settings	Access the settings menu	Press graphic button
Trip	Access to the Trip menu	Press graphic button

(*) **Uconnect™ 7" HD Nav versions only**

Steering wheel controls

The controls for the main system functions are present on the steering wheel to make control easier. The activation of the function selected is controlled, in some cases, by how long the button is pressed (short or long press) as described in the table below.







216

F0S0622



Steering wheel controls summary table

Buttons	Interaction
	<ul style="list-style-type: none"> <input type="checkbox"/> Acceptance of incoming call <input type="checkbox"/> Answering the second incoming call and putting the active call on hold <input type="checkbox"/> Last 10 calls list on the instrument panel (with call browsing active and phone paired only)
	<ul style="list-style-type: none"> <input type="checkbox"/> Activation of voice recognition <input type="checkbox"/> Interruption of the voice message in order to give a new voice command <input type="checkbox"/> Interruption of voice recognition <input type="checkbox"/> Long press: interaction with Siri, Apple CarPlay and Android Auto
	<ul style="list-style-type: none"> <input type="checkbox"/> Rejection of incoming call <input type="checkbox"/> Ending of call in progress <input type="checkbox"/> Exit the display on the instrument panel of the last calls (only with call browsing active)
	<ul style="list-style-type: none"> <input type="checkbox"/> Short press (Radio mode): selection of next/previous station <input type="checkbox"/> Long press (Radio mode): scan higher/lower frequencies until released <input type="checkbox"/> Short press (USB, Bluetooth® mode): selection of previous/next track <input type="checkbox"/> Long press (USB, Bluetooth® mode): fast forward/rewind until released <input type="checkbox"/> Short press (phone mode): selection of next/previous call (only with call browsing active)
	<ul style="list-style-type: none"> <input type="checkbox"/> Short press: volume increase/decrease in single steps <input type="checkbox"/> Long press: volume continuous increase/decrease until released

Switching the system on/off

The system is switched on/off by pressing the button/knob .

Turn the button/knob clockwise to increase the radio volume or anticlockwise to decrease it. The electronic volume adjustment control rotates continuously (360°) in both directions, without stop positions.

Radio mode

After the desired radio station is selected, the following information is shown on the display:

At the top: the list of radio stations stored (preset) is displayed; the station currently playing is highlighted.

In the middle: display of the name of the current radio station and the buttons for selecting the previous or next radio station.

On the left: display of the "AM", "FM", "DAB" buttons for selecting the desired frequency band (reconfigurable button depending on the selected band: AM, FM or DAB);

NOTE The DAB frequency can be used in countries where digital transmission technology is available. The device will not be tuned to any frequency if the DAB button is pressed in a country where the service is not provided.

On the right: display of the following buttons:

- "Info": additional information on the source being listened to;
- "Map": navigation map view (versions with **Uconnect™ 7" HD Nav** only).

At the bottom: display of the following buttons:

- "Browse": list of the radio stations available;
- : selecting previous/next radio station;
- "Tune": manual radio station tuning;
- "Audio": access to the "Audio Settings" screen.

Audio menu

To access the "Audio" menu press the Audio button located at the bottom of the display. The following adjustments can be carried out using the "Audio" menu:

- "Balance & Fader" (left/right and front/rear audio balance adjustment);
- "Equalizer" (where provided);
- "Speed Adj Volume" (speed-dependent automatic volume control);
- "Loudness" (where provided);
- "AutoPlay";
- "Auto-On Radio".

Media mode

Press the "Media" graphic button to select the desired audio source among those available: USB, **Bluetooth®**.

WARNING Applications used on portable devices may be not compatible with the **Uconnect™** system.

After Media mode is selected, the following information is shown on the display:

At the top: information on the track being played and the following graphic buttons:

- "Repeat": to repeat the track being played;
- "Shuffle": to play the tracks in random order.

In the middle: information on the track being played.

On the left: display of the following buttons:

- Selected device or audio source;
- "Select source": select the required audio source.

On the right: display of the following buttons:

- "Info": additional information on the track being played;
- "Tracks": list of available tracks.
- "Map": navigation map view (versions with **Uconnect™ 7" HD Nav** only).

At the bottom: information on the track being played and the following graphic buttons:

- Active device or audio source;



- ◀◀ / ▶▶: previous/next track selection;
- ||: pause track being played;
- "Audio": access to the "Audio Settings" screen.

Track selection

Use this function to scroll through and select the tracks on the active device. The choices available depend on the device connected. For example, on a USB device, you can also use the SCROLL TUNE button/knob to scroll through the list of artists, genres and albums available on the device, depending on the information available in the tracks.

Turn the SCROLL TUNE button/knob to select the desired category and then press the button/knob to confirm the selection.

NOTE The indexing time of a USB device can vary depending on the media inserted (in some cases it can take a few minutes).

NOTE The **Uconnect™** system may not support some USB keys: in this case, it will not automatically switch from "Radio" mode to "Media" mode. If the device used does not play, verify its compatibility by selecting Media mode: a dedicated message will appear on the **Uconnect™** system display.

IMPORTANT After using a USB recharging socket, we recommend disconnecting the device (smartphone), always removing the cable from the vehicle socket first, never from the device.

NOTE The USB ports handle data transmission from the Pen Drive/Smartphone, etc. and slow recharging of an external device, which is not guaranteed as it depends on the device type/brand.

Bluetooth® SOURCE

This mode is activated by pairing a **Bluetooth®** device containing music tracks with the system.

PAIRING A Bluetooth® AUDIO DEVICE

To pair a **Bluetooth®** audio device, proceed as follows:

- activate the **Bluetooth®** function on the device;
- press the "Media" graphic button on the display;
- press the "Select Source" button;
- select the **Bluetooth®** Media source;
- press the "Add Device" graphic button;
- search for "Uconnect" on the **Bluetooth®** audio device (during pairing, a screen showing the progress is displayed);

□ when requested by the audio device, enter the PIN code shown on the system display or confirm on the device the PIN displayed;

□ if the pairing procedure is completed successfully, a screen is displayed. Answer "Yes" to the question to pair the **Bluetooth®** audio device as favourite (the device will have priority over all other devices to be paired subsequently). If "No" is selected, the priority is determined according to the order of connection. The last device connected will have the highest priority; □ an audio device can also be paired by pressing the "Phone" graphic button on the display and by selecting "Settings" or selecting "Phone/**Bluetooth®**" from the "Settings" menu.

WARNING If the **Bluetooth®** connection between mobile phone and system is lost, consult the mobile phone handbook.

NOTE When modifying the name-device in the **Bluetooth®** settings of the phone (where provided), the Radio may change the track being played if the device is connected via USB after the **Bluetooth®** connection.

After updating the phone software, for proper operation, it is recommended

to remove the phone from the list of devices linked to the radio, delete the previous system pairing also from the list of **Bluetooth®** devices on the phone and make a new pairing.

USB SOURCE

To activate the USB mode, insert the corresponding device into the USB port on the central console. If a USB device is inserted with the system on, it will start playing the tracks found on the device.

TRIP COMPUTER

Press the "Trip" button on the display to view the car's trip information.

This function consists of "Trip A" for monitoring the "complete mission" (journey) of the car and, for versions/markets where provided, "Instant info" and "Best average consumption".

Trip A can be reset (to start a new trip).

PHONE MODE

PHONE MODE ACTIVATION

Press the "Phone" button on the display to activate the Phone mode.

To consult the list of mobile phones and functions supported, contact Customer Care on the number provided in the Warranty or visit the www.UCONNECTPHONE.com website

Use the graphic buttons on the display to:

- dial the phone number (using the graphic dial pad on the display);
- display and call the contacts in the phonebook of the mobile phone;
- display and call contacts from the registers of previous calls;
- pair up to 10 phones/audio device to make access and connection easier and quicker;
- transfer calls from the system to the mobile phone and vice versa and deactivate the microphone audio for private conversations.

The mobile phone audio is transmitted through the car's sound system; the system automatically mutes the radio when the Phone function is used.

PAIRING A MOBILE PHONE

IMPORTANT Only perform this operation with the vehicle stationary and in safe conditions; this function is deactivated when the vehicle is moving. The pairing procedure for a mobile phone is described below: always consult the handbook for the mobile phone in any case. To pair the mobile phone, proceed as follows:

- activate the **Bluetooth®** function on the mobile phone;
- press the "Phone" graphic button on the display;

□ if no phone is paired with the system yet, the display shows a dedicated screen;

□ access "Settings" and type "Add Device" to start the pairing procedure, then search for the **Uconnect™** device on the mobile phone;

□ when prompted by the mobile phone, use its keypad to enter the PIN code shown on the system display or confirm on the mobile phone the PIN displayed;

□ during the pairing stage a screen appears on the display showing the progress of the operation;

□ when the pairing procedure is completed successfully, a screen is displayed: answer "Yes" to the question to pair the mobile phone as favourite (the mobile phone will have priority over all other mobile phones to be paired subsequently). If no other devices are paired, the system will consider the first paired device as the favourite.

NOTE To ensure proper operation after updating the phone software, it is recommended to remove the phone from the list of devices linked to the radio, delete the previous system pairing also from the list of **Bluetooth®** devices on the phone and make a new pairing.

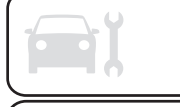

MAKING A PHONE CALL

The operations described below can only be accessed if supported by the mobile phone in use. For all functions available, refer to the mobile phone owner's handbook.

A call can be made by:

- selecting "Phonebook";
- selecting "Recent";
- selecting "Dial";

FAVOURITES

You can add a number or a contact (if already in Contacts) to the favourite list during a call by pressing one of the five "Empty" graphic buttons on the upper part of the display. The favourites can also be managed by using the Phone Book options.

TEXT MESSAGE READER

The system can read the messages received by the mobile phone. To use this function, the mobile phone must support the text exchange function through **Bluetooth®**.

If this operation is not supported by the phone, the corresponding "Text message" graphic button is deactivated (greyed out). When a text message is received, the display will show a screen where the options "Read", "Show", "Call" or "Ignore" can be selected.

Press the "Text" graphic button to access the list of text messages

received by the mobile phone (the list displays a maximum of 60 messages received).

NOTE On some mobile phones, to make the text message voice reading function available, the text message notification option on the phone must be enabled; this option is usually available on the phone, in the **Bluetooth®** connections menu for a device registered as **Uconnect™**.

After enabling this function on the mobile phone, it must be disconnected and reconnected with the **Uconnect™** system in order to make it effective.

TEXT MESSAGE OPTIONS

Predefined messages are stored in the system memory and can be sent to answer a received message or as a new message:

- Yes.
- No.
- Okay.
- I can't talk right now.
- Call me.
- I'll call you later.
- I'm on my way.
- Thanks.
- I'll be late.
- Stuck in traffic.
- Start without me.
- Where are you?

- Are you there yet?
- I need directions.
- I'm lost.
- See you later.
- I will be delayed by 5 (or 10, 15, 20, 25, 30, 45, 60) minutes (*).
- See you in 5 (or 10, 15, 20, 25, 30, 45, 60) minutes (*).
- (*) Only use the numbers listed, otherwise the system will not take the message.

DO NOT DISTURB FUNCTION

By pressing the "Do not disturb" graphic button the user will not receive notifications in case of incoming calls or text messages. The user can reply with a default or customised message by means of the settings.

SIRI EYES FREE

(available only with iPhone 4S and subsequent versions and compatible iOS versions) After having paired the Siri enabled device to **Uconnect™**, hold the  button on the steering wheel pressed and then release it. After the double beep, you can start interacting with Siri, to listen to music, get directions, read text messages and more.

APPS MODE

Press the "Uconnect" button on the display to access the radio menu

containing all the system application operations.

The menu includes the following items:

- "Uconnect™ LIVE";
- "Media";
- "Phone";
- "Settings";
- "Radio";
- "Trip".

Apple CarPlay and Android Auto

(for versions/markets, where provided)

The Apple CarPlay and Android Auto applications allow you to use your smartphone in the car safely and intuitively.

To enable them, just connect a compatible smartphone to the USB port and the contents of the phone will be automatically shown on the **Uconnect™** system display.

To check the compatibility of your smartphone, see the indications on the websites: https://www.android.com/intl/it_it/auto/ and <http://www.apple.com/it/ios/carplay/>. If the smartphone is connected correctly to the car via the USB port, the Apple CarPlay or Android Auto icon will be displayed in place of the  button in the main menu.

Android Auto – app configuration

Before use, download the Android Auto application to your smartphone from Google Play Store.

The application is compatible with Android 5.0 (Lollipop) and later versions.

To use Android Auto, the smartphone must be connected to the car with a USB cable.

On the first connection, you will have to perform the setup procedure that appears on the smartphone. You can only perform this procedure with the vehicle stationary.

Apple CarPlay – app configuration

Apple CarPlay is compatible with the iPhone 5 or more recent models, with the iOS 7.1 operating system or later versions.

Before using Apple CarPlay, enable Siri from Settings > General > Siri on the smartphone.

To use Apple CarPlay, the smartphone must be connected to the car with a USB cable.

NOTE Enabling Apple CarPlay/Android Auto or some functions could require interaction on the smartphone. If necessary, complete the step on your device (smartphone).

Interaction

After the setup procedure, the application will run automatically on the **Uconnect™** system when your smartphone is connected to the USB port in the car. You can interact with Apple CarPlay and Android Auto using the steering wheel controls (long press of the  button), using the SCROLL TUNE button/knob to select and confirm or using the **Uconnect™** system touchscreen.

Navigation

With the Apple CarPlay and Android Auto applications, the user can choose to use the navigation system on their smartphone.

If the system "Nav" mode is already on, a warning pop-up will appear on the **Uconnect™** system display when a device is connected to the car with a navigation session in progress. The pop-up allows the user to choose between using the system navigation and using navigation controlled by the smartphone.

The user can choose to change their selection at any time by accessing the navigation system that they want to use and setting a new destination.



Setting "AutoShow smartphone display on connection"

Through the **Uconnect™** system settings, the user can decide to view the smartphone screen on the Uconnect™ system display as soon as the smartphone is connected via the USB port. When this function is set, each time a connection is made via USB, the Apple CarPlay or Android Auto apps will run automatically on the radio screen.

The "**AutoShow smartphone display on connection**" item can be found in the "Display" submenu.

The function is enabled by default.

NOTES

- Bluetooth®** is disabled while Apple CarPlay is being used
- Bluetooth®** remains on while Android Auto is being used
- The data connection will depend on the tariff plan of the smartphone
- This information may be subject to changes that depend on the smartphone's operating system.

Exiting from the Apple CarPlay and Android Auto apps

You can still access the contents of the **Uconnect™** system with the CarPlay app enabled by using the controls available and viewable on its display. To return to the **Uconnect™** system

contents with the Android Auto app enabled, select the last item on the Android Auto system bar and select "Back to Uconnect".

To end the Apple CarPlay or Android Auto session, physically disconnect the smartphone from the USB port.

SETTINGS

Press the "Settings" graphic button on the display to show the main "Settings" menu.

NOTE

The menu items displayed vary according to the versions. The menu includes the following items:

- Language;
- Display;
- Units;
- Voice Commands;
- Time and Date;
- Safety & Driving Assistance (for versions/markets, where provided);
- Lights;
- Doors & Locks;
- Vehicle Off Options;
- Audio;
- Phone;
- Radio Setup;
- Restore Default Settings;
- Clear Personal Data.

NAVIGATION (Uconnect™ 7" HD Nav only)

Press the "Nav" graphic button to show the navigation map on the display.

NOTE: The navigation system volume can only be adjusted during navigation when the system provides voice indications.

Navigation main menu

In the navigation view, tap the "Main menu" button to open the menu:

- Select the "Search" graphic button to search for an address, a place or a Point of Interest, and then plan a route to that location.
 - Select the "Current route" graphic button to delete or change the planned route.
 - Select the "My Places" button to create a collection of useful or preferred addresses. The following items are always available in "My Places": "Home" and "Recent Destinations".
 - Select the "Parking" button to search for car parks.
 - Select the "Weather" or "Report Speed Camera" button to receive information on the weather or warnings about speed camera locations.
- NOTE The "Weather" and "Report Speed Camera" functions are only active if TomTom Services are activated. Otherwise, the button will

appear greyed out (and the function will not be available).

Select the “Petrol station” graphic button to search for petrol stations.

Select the “TomTom Services” button to view the activation state of the following services (subscription needed): “Traffic”, “Speed Cameras”, “Weather”, “Online search”.



Press this button to open the “Settings” menu;



Select this graphic button to open the “Help” menu. The Help Menu contains information about the **Uconnect™** system, for example, map version, device serial number and legal information.



Select this button to return to the navigation view.



Select this graphic button to activate/deactivate voice instructions. Select off to no longer hear voice instructions. You will still receive

information such as traffic information and warning sounds. **Tip:** you can deactivate the warning sounds by selecting “Settings”, then “Sounds and warnings”.



Select this graphic button to increase/decrease the screen brightness and display the map in brighter/darker colours. When driving at night or in unlit tunnels, watching the screen is more comfortable and less distracting for the driver if the map uses darker colours. **Tip:** the device will automatically switch between day and night view depending on the time of day. To deactivate this function, select “Appearance” in the “Settings” menu and deselect the option “Switch to night colours” when it is dark

Map update

To ensure optimal performance, the navigation system must be updated periodically. For this reason, the **Mopar® Map Care** service offers a new map update every three months. The updates can be downloaded from the maps.mopar.eu website and installed directly on the navigator in your car. All updates are free of charge for 3 years from the start of the warranty on the car. The navigation

system can also be updated at the Fiat Dealership (the dealer may charge for updating the navigation system).

VOICE COMMANDS

NOTE For languages not supported by the system, voice commands are not available.

To use the voice commands, press the button on the steering wheel  and say out loud the command you want to activate.

Global

The following voice commands can be given after pressing the button on the steering wheel 

- Help
- Cancel
- Repeat
- Voice tutorial

Phone

The following voice commands can be given after pressing the button on the steering wheel 

- Call...
- Dial...
- Redial
- Call back
- Show recent calls
- Show outgoing calls
- Show missed calls
- Show incoming calls

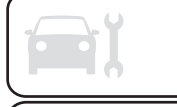

- ❑ Contacts
- ❑ Search...
- ❑ Show text message
- ❑ Send a text message to...
- ❑ Show messages

Radio

The following voice commands can be given after pressing the button on the steering wheel  :

- ❑ Tune to FM "frequency"
- ❑ Tune to AM "frequency"
- ❑ Tune to "radio name" FM

Media

The following voice commands can be given after pressing the button on the steering wheel  :

- ❑ Play song...
- ❑ Play album...
- ❑ Play artist...
- ❑ Play genre...
- ❑ Play playlist...
- ❑ Play podcast...
- ❑ Play audiobook...
- ❑ Select the source...
- ❑ View...

Navigation (Uconnect™ 7" HD Nav only)

The following voice commands can be given after pressing the button on the steering wheel  :

- ❑ Find "POI"

- ❑ Navigate to "address"
- ❑ Go to "city name" centre
- ❑ Navigate to an address
- ❑ Drive towards a town centre
- ❑ Navigate home
- ❑ Go via home
- ❑ Clear route
- ❑ Add current location to "My Places"
- ❑ View "My Places"
- ❑ Go through a saved location
- ❑ Recent Destinations
- ❑ Stop at a recent destination
- ❑ Increase zoom
- ❑ Zoom out
- ❑ 2D view
- ❑ 3D view
- ❑ Report Speed Camera
- ❑ Report Risk Zone

NOTE Voice entry of addresses is only supported in the country in which you are located and only if the system language matches the local language. For example, if the car is located in Italy, it will be possible to enter Italian addresses only if the system language is set to "Italian".

MOPAR® CONNECT

(where provided)

These services let you keep your car under control at all times and receive assistance in the event of accident, theft or breakdown.

Availability of the services depends on the country (list available on the www.driveuconnect.eu website). Request activation by following the instructions received at the email address given when your car was handed over to you.

SERVICES

According on the equipment of the car and of the country, different services may be available for different durations. For further information about your car, go to the personal page on the official Fiat website.

The following are some of the packages available to the customer:

my:Assistant: package for customer assistance in the event of an accident, breakdown or attempted theft.

The package is accessible from the **Uconnect™** app and can also detect unauthorised car towing or tampering.

my:RemoteControl: package for managing remote functions from the **Uconnect™** smartphone app, such of the car location on the map or locking/unlocking the doors, unlocking

the boot and flashing the hazard warning lights for 4 seconds.

my:Car: package for using **Uconnect™** app to remotely monitor the car, such as the fuel level and tyre pressures. The package also includes the Vehicle Condition Report to check the state of health of the car via web and with a monthly email.

my:Journey: package for using the **Uconnect™** app to display and manage travel, with dates, maps, personal notes and travel reports. Download the **Uconnect™** app for smartphones or access the www.driveuconnect.eu portal to use the connected services.

Full details of the services in the **Mopar@Connect** section of the www.driveuconnect.eu portal.

The main functions of the **my:RemoteControl**, **my:Car** and **my:Journey** packages (where provided) can be run using Google Assistant voice commands (where provided), in addition to the **Uconnect™** app and the web portal www.driveuconnect.eu.

With **Mobility Services**, it is also possible to take advantage of proposals from manufacturer partners.

PRIVACY MODE

Privacy mode lets you disable the “Find car”, “Notify Area” and “Notify

Speed” services, which allow registered customers to locate their cars, for a fixed time.

WARNING Car position tracing remains active for the assistance services, where provided, in the event of accident or car theft, but is not visible to the customer.

PRIVACY MODE activation procedure

Proceed as follows:

- take note of the total odometer reading;
- make sure that the instrument panel is off;
- Send the following text message to +393424112613: “PRIVACY <CAR_CHASSIS_NUM> <TOTAL_MILEAGE_KM>” (e.g.: PRIVACY ZFA3340000P12345612532). You can find the vehicle identification number in the registration document;
- before starting the engine, wait to receive the text message confirming that Privacy mode has been activated and indicating when it expires.

When you have received the confirmation, you can start your trip in the knowledge that the car will not be tracked until the indicated expiry time. If it expires while you are still travelling,

Privacy mode will be extended until you turn off the engine (instrument panel off).

If you receive a text message indicating that your request was not successful, you must be aware that the car will continue to be visible to the registered customer.

If you have any problems during activation, consult the FAQ on the www.driveuconnect.eu portal, contact the Fiat Dealership or contact Customer Care.

OFFICIAL TYPE APPROVALS

RADIO DEVICES

All radio equipment provided with the car complies with Directive 2014/53/EU, UA.RED.TR, the French SAR Decree Law of 15/11/2019 and the UKCA (UK Conformity Assessed) Certification of 01/01/2023 in force in the United Kingdom. For further information go to www.mopar.eu/owner or <http://aftersales.fiat.com/elum>

RADIO FREQUENCY DEVICES

All radio frequency devices comply with the regulations in force in the countries in which they are sold.



For further information go
to www.mopar.eu/owner or
<http://aftersales.fiat.com/elum>.

RIGHT-HAND DRIVE VERSION

DASHBOARD

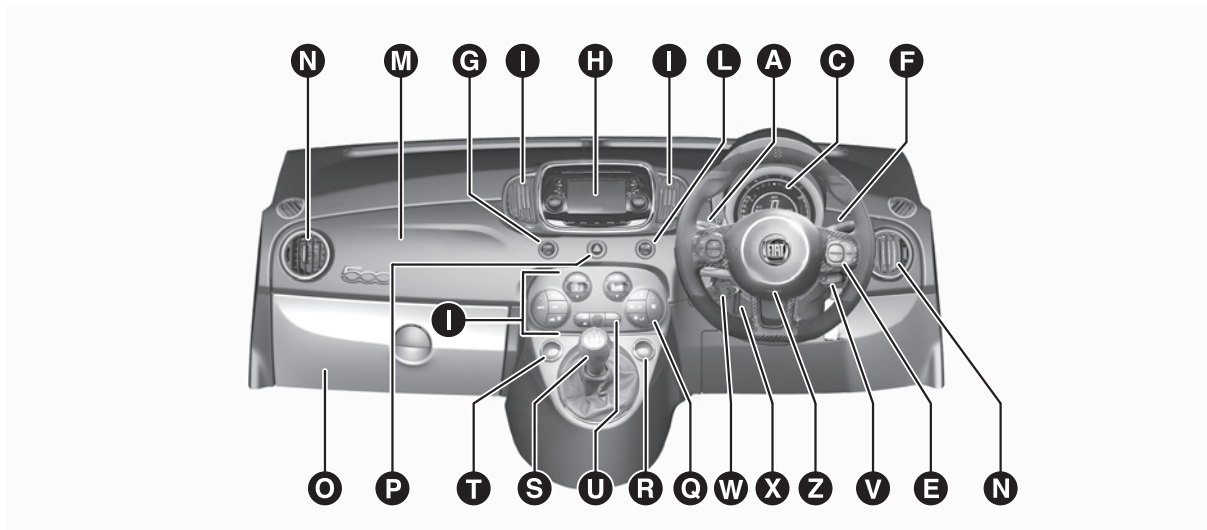

217

F0S0817

A . Light/direction indicator stalk B. Audio controls on the steering wheel C. Instrument cluster D. Headlight alignment corrector E. Audio controls on the steering wheel F. Windscreen washer/wiper + rear window wiper stalk G. Dualdrive electric steering (CITY function) / ECO function H. **Uconnect™** I. Central air vents L. Fog light/rear fog light M. Passenger's airbag N. Side air diffusers O. Glove compartment P. Hazard warning lights switch Q. Climate controls R. Right electric window S. Gear lever T. Left electric window U. ASR-OFF button V. Ignition device W. Cruise Control/Speed Limiter lever X. Steering wheel adjustment lever Z. Driver's airbag

**In the heart
of your engine.**



PETRONAS
SELENIA



*Always ask your mechanic for **PETRONAS Selenia.***

PETRONAS
SELENIA



Oil change? The experts recommend PETRONAS Selenia

*The engine of your car is factory filled with **PETRONAS Selenia**. This is an engine oil range which satisfies the most advanced international specifications. Its superior technical characteristics allow **PETRONAS Selenia** to guarantee the highest performance and protection of your engine.*

The PETRONAS Selenia range includes a number of technologically advanced products:

PETRONAS Selenia K Power

Fully synthetic lubricant developed for American design petrol engines.

PETRONAS Selenia WR Forward

Fully synthetic Low SAPS lubricant for Euro 6 diesel engines. High fuel economy.

PETRONAS Selenia Digitek Pure Energy

Fully synthetic lubricant for petrol engines. High fuel economy characteristics.

PETRONAS Selenia Multipower Gas

Fully synthetic lubricant for petrol engines supplied with methane or LPG. Protection against valve wear.

PETRONAS Selenia Multipower C3

Synthetic lubricant for petrol and diesel engines. Fuel economy characteristics.

The range also includes Selenia K, Selenia 20K, Selenia Turbo Diesel, Selenia Sport, Selenia Sport Power, Selenia Racing, Selenia WR, Selenia WR Pure Energy.

**CHOOSING GENUINE PARTS
IS THE MOST NATURAL CHOICE**



HOW TO RECOGNISE GENUINE PARTS

To recognise a **Genuine Part**, check **that the component bears our brands**, always clearly visible on Genuine Parts, from the braking system to windscreen wipers, from shock absorbers to pollen filter.

All **Genuine Parts** undergo **strict controls**, both during design and manufacturing stages, by specialists using **vanguard materials**, to **test the component reliability**.

This to guarantee **performance** and **safety** for you and your passengers on board, for a long time. Always ask for and make sure a **Genuine Part** has been used.



Pollen filter

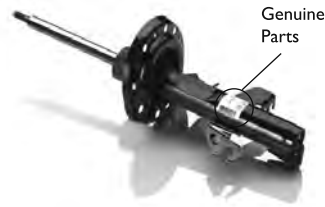

Shock absorber



Brake pads

CONTENTS

A BS	91	Cup/bottle holders	43	Engine oil (level check)	172
Active safety systems	91	D ashboard	12	EOBD system	69
ASR system	91	Daytime running lights	22	ESC system	91
Auxiliary lithium battery	179	Demanding use of the car	166	Extending the boot	17
B odywork (cleaning and maintenance)	183	Digital engine coolant temperature gauge	52	External lights	22
Bonnet	43, 46	Digital fuel level gauge	52	F iat CODE system	16
Boot	42	Dimensions	205	Fix&Go kit	158
Brake fluid	172	Dipped beam headlights/side lights	22	Fixed glass sunroof	35
Brakes		Direction indicators	22	Fog lights/rear fog lights	22
features	195	Display	55	Follow Me Home	22
maintenance	179	Doors	16	Front airbags	112
C ar inactivity	182	Driving assistance systems	94	Front ceiling light	26
Changing a wheel	154	Driving tips	138	Front seats	17
Chassis marking	189	Dualdrive electric power steering	127	Fuel consumption	214
Checking levels	172	Dualogic transmission	123	Fuel cut-off system	163
Child restraint systems	101, 112	E BD system	91	Fuel tank cap	140
Cigarette lighter	43	ECO function	127	Fuses (replacement)	152, 154
Climate control system	29	Electric handle (Soft Touch)	42	G love compartment	43
Clutch	194	Electric windows	35	H andbrake	121
CO ₂ emissions	214	Electronic Cruise Control	134	Hazard warning lights	144
Conventional battery		Engine		HBA system	91
inspecting the charge	176	technical specifications	191	Head restraints	20
replacement	176	Engine compartment (washing)	183	HH system	91
Correct reading of the rim code	198	Engine cooling system fluid	172	Hybrid system	128
Correct reading of the tyre	198	Engine oil (consumption)	172	I dentification data	
				body paint identification plate	189
				VIN plate	189



Ignition device	15	Rear seats	17	Speedometer	52
Instrument panel features	52	Rear window washer (jets)	180	Start&Stop system	129
Intake system	193	Rear window wiper / washer	26	Starting the engine	120
Interior fittings	43	Rear-view mirrors	21	Steering	197
Interior lights	26	RED special series	49	Steering lock	15
Interiors (cleaning)	186	Refuelling	208	Steering wheel	21
iTPMS	94	Refuelling the Vehicle	140	Sun visors	43
J ump starting	161	Replacing a bulb	144	Sunroof	35
K ey with remote control	14	Replacing an exterior bulb	144	Supplementary Restraint System (SRS) - Airbag	112
Keys	14	Replacing the windscreen/rear window wiper blades	180	Suspension	196
M ain beam headlights	22	Rim Protector (tyres)	198	T achometer	52
Manual transmission	122	Rims and wheels	198	Technical specifications	189
Mechanical key	14	Roof rack/ski rack	45	Towable weights	207
Motor marking	189	S aving fuel	138	Towing the vehicle	163
MSR system	91	SBR system	97	Towing trailers	142
O ccupant protection systems	96	Scheduled servicing	166	Transmission	194
Official type approvals	255	Seat belts	96	Transporting animals	138
P aintwork (maintenance)	183	Seats	17	Transporting passengers	138
Parking lights	22	Service Schedule	166	Trip computer	65...66
Parking sensors	136	Side bag	101	Tyres (inflation pressure)	198
Performance (top speed)	213	Side bags	112	U connect™ tips, controls and general information	217
Periodic checks	166	Snow chains	198	USB source	218
Power socket	43	Snow tyres	198	Uconnect™ 5" Radio / NAV	231
Pre-tensioners	99	Soft top	37	Uconnect™ 7" HD / NAV	242
R adio / Radio DAB+	226	Space-saver wheel	198		
Raising the car	181	Spark plugs (type)	191		
Rear fog lights	22	Speed Limiter	132		

Uconnect™ Radio	
Controls on front panel	219
Media mode	219
Radio mode	219
Settings	219
Steering wheel controls	219
System on/off	219
USB input	43
V ersion with LPG system	46
W arning lights on panel	70
Weights and loads	206
Wheels and tyres	181
Window bag	112
Windscreen washer (jets)	180
Windscreen wiper / washer	26
Windscreen/rear window washer fluid	172



WHY CHOOSING GENUINE PARTS

We really know your car because we invented, designed and built it: we really know every single detail.

At **Fiat Service authorised workshops** you can find technicians directly trained by us, offering quality and professionalism for all service operations.

Fiat workshops are always close to you for the regular servicing operations, season checks and practical recommendations by our experts.

With Original Parts distributed by MOPAR[®], you maintain the reliability, comfort and performance features that you bought your new car for over time.

Always ask for Genuine Parts for the components used on our cars; we recommend them because they come from our steady commitment in research and development of highly innovative technologies.

For all these reasons: **rely on Genuine Parts, because they are the only ones designed by FCA for your car.**

SAFETY:
BRAKING SYSTEM

ENVIRONMENT: PARTICULATE FILTERS,
CLIMATE CONTROL MAINTENANCE

COMFORT: SUSPENSION
AND WINDSCREEN WIPERS

PERFORMANCE: SPARK PLUGS,
INJECTORS AND BATTERIES

LINEACCESSORI
ROOF RACK BARS, WHEEL RIMS

The data contained in this publication is intended merely as a guide. FCA Italy S.p.A. reserves the right to modify the models and versions described in this booklet at any time for technical and commercial reasons.

If you have any further questions please consult your FIAT dealer.

Printed in recycled paper without chlorine.